

**558J SINGLE PACKAGED ROOFTOP
COOLING ONLY/ELECTRIC HEAT
6 TO 15 NOMINAL TONS**



Product Data

**LEGACY™
LINE**



Shown with optional hail guard

TABLE OF CONTENTS

	PAGE		PAGE
FEATURES/BENEFITS.....	3	APPLICATION DATA.....	44
MODEL NUMBER NOMENCLATURE.....	4	PERFORMANCE DATA.....	46
CAPACITY RATINGS.....	5	ELECTRICAL DATA.....	54
PHYSICAL DATA.....	22	CONTROLS.....	98
OPTIONS AND ACCESSORIES.....	25	GUIDE SPECIFICATIONS.....	101
DIMENSIONS.....	28		



Bryant's Legacy™ Line 6 to 15 Ton rooftop unit (RTU) was designed by customers for customers. With “no-strip” screw collars, handled access panels, and more we've made your unit easy to install, easy to maintain, easy to use and reliable.

Easy to install:

All Legacy Line units are field-convertible to horizontal air flow which makes it easy to adjust to unexpected job site complications. Lighter units make easy replacement. Most Bryant 558J rooftops fit on existing Bryant curbs dating back to 1989. Also, our large control box gives you room to work and room to mount Bryant accessory controls.

Easy to maintain:

Easy access handles by Bryant provide quick and easy access to all normally serviced components. Our “no-strip” screw system has superior holding power and guides screws into position while preventing the screw from stripping the unit's metal.

Easy to use:

The newly designed, central terminal board by Bryant puts all your connections and troubleshooting points in one convenient place, standard. Most low voltage connections are made to the same board and make it easy to find what you're looking for and easy to access it. Bryant rooftops have high and low pressure switches, a filter drier, and 2-in. (51mm) standard filters.

FEATURES/BENEFITS

- Single circuit, single stage cooling model on 6 ton
- Single circuit, 2-stage cooling models are available from 7.5 to 10 ton.
- Dual circuit, 2-stage cooling stage models are available from 7.5 to 15 ton.
- EERs up to 11.3 with IEERs up to 13.0
- 2-speed indoor fan motor system automatically adjusts the indoor fan motor speed between cooling stages. Standard on all 558J*08-16D/K units for installation in the United States to meet the Department of Energy (DOE) efficiency standard of 2018. Factory option for all 558J*08-16D/K unit installations outside the United States. 558J*08/09/12/N units meet the DOE 2018 efficiency standard without the 2-speed indoor fan motor system option.
- Standardized components and layout. Standardized components and controls make service and stocking parts easier.
- Scroll compressors on all units. This makes service, stocking parts, replacement, and troubleshooting easier.
- Field convertible airflow (6-12.5 ton). Being able to convert a unit from vertical airflow to horizontal makes it easy to overcome job site complications. A 15 ton model requires a simple supply duct cover to field convert from factory vertical to horizontal.
- Easy-adjust, belt-drive motor available. There's no need for field-supplied drives or motors.
- Provisions for bottom or side condensate drain.
- Capable of thru-the-base or thru-the-curb gas line routing.
- Single-point electrical connection.
- Internally sloped, composite drain pan sheds water; and won't rust.
- Standardized controls and control box layout. Standardized components and controls make stocking parts and service easier.
- Clean, large, easy to use control box.
- Color-coded wiring.
- Large, laminated wiring and power wiring drawings which are affixed to unit make troubleshooting easy.
- Single, central terminal board for test and wiring connections.
- Fast-access, handled, panels for easy access to the blower and blower motor, control box, and compressors.
- "No-strip" screw system guides screws into the panel and captures them tightly without stripping the screw, the panel, or the unit.
- Exclusive, newly designed indoor refrigerant header for easier maintenance and replacement.
- Mechanical cooling 115°F to 40°F (46°C to 4°C) standard on all models. Winter Start Kit allows cooling operation down to 25°F (-4°C) and Motormaster® controller to -20°F (-29°C).
- 2-in. (51mm) disposable filters on all units.
- Refrigerant filter-drier on each circuit protected with a high and low pressure switch.
- Factory-installed Perfect Humidity™ adaptive dehumidification system on all sizes with round tube/plate fin (RTPF) condenser coils, includes Motormaster I controller.
- Many factory-installed options ranging from air management economizers, 2 position dampers, plus convenience outlets, disconnect switches and smoke detectors.
- Standard Warranty (limited parts only): 5-year compressor, 5-year electric heater (field-installed only), 5-year Ultra Low Leak Economizers, 3-year Novation® condenser coil, 1-year Round Tube/Plate Fin (RTPF) condenser coil parts, and 1-year limited on all parts.

MODEL NUMBER NOMENCLATURE

Position:	1	2	3	4	5	6	7	8	9	10	11	12	13	14	15	16	17
Example:	5	5	8	J	E	0	8	D	0	0	0	A	1	A	0	A	A

Unit Type

558 - Cooling RTU with optional Electric Heat - Legacy™ Line

Model

J - Puron® (R-410A) Refrigerant

Voltage

E = 460-3-60
P = 208/230-3-60
T = 575-3-60 (not available for 558J_08N units)

Cooling Tons

07 - 6 tons
08 - 7.5 tons
09 - 8.5 tons
12 - 10 tons
14 - 12.5 tons
16 - 15 tons

Refrig. System

A = One-stage cooling (07 only)
D = Two-stage cooling models (08-16)
G = One-stage cooling with Perfect Humidity™ system (07 only)
K = Two-stage cooling models with Perfect Humidity system (08-16)
N = Single Circuit Two-stage cooling models (08-12 only)

Heat Level

(Field install electric heaters available)
000 = No Heat

Coil Options For Round Tube/Plate Fin Condenser Coil Models Only (Outdoor - Indoor - Hail Guard)

A = Al/Cu - Al/Cu
B = Precoat Al/Cu - Al/Cu
C = E-coat Al/Cu - Al/Cu
D = E-coat Al/Cu - E-coat Al/Cu
E = Cu/Cu - Al/Cu
F = Cu/Cu - Cu/Cu
M = Al/Cu - Al/Cu — Louvered Hail Guard
N = Precoat Al/Cu - Al/Cu — Louvered Hail Guard
P = E-coat Al/Cu - Al/Cu — Louvered Hail Guard
Q = E-coat Al/Cu - E-coat Al/Cu — Louvered Hail Guard
R = Cu/Cu - Al/Cu — Louvered Hail Guard
S = Cu/Cu - Cu/Cu — Louvered Hail Guard

Coil Options For All Aluminum - Novation® Condenser Coil Models Only (Outdoor - Indoor - Hail Guard)

G = Al/Al - Al/Cu
H = Al/Al - Cu/Cu
J = Al/Al - E-coat Al/Cu
K = E-coat Al/Al - Al/Cu
L = E-coat Al/Al - E-coat Al/Cu
T = Al/Al - Al/Cu — Louvered Hail Guard
U = Al/Al - Cu/Cu — Louvered Hail Guard
V = Al/Al - E-coat Al/Cu — Louvered Hail Guard
W = E-coat Al/Al - Al/Cu — Louvered Hail Guard
X = E-coat Al/Al - E-coat Al/Cu — Louvered Hail Guard

Packaging and 2-Speed Indoor Fan Motor

A = Standard Packaging, electro-mechanical controls that require W7212 EconoMi\$er® IV
B = LTL Packaging, electro-mechanical controls that require W7212 EconoMi\$er IV
C = Standard Packaging, electro-mechanical controls that require W7220 EconoMi\$er X
D = Standard Packaging and 2-Speed Indoor Fan Motor (VFD) Controller
E = LTL Packaging and 2-Speed Indoor Fan Motor (VFD) Controller
F = LTL Packaging, electro-mechanical controls that require W7220 EconoMi\$er X

Factory Installed Options

0A = None

NOTE: See the 558J 6 to 15 ton Price Pages for a complete list of factory installed options.

Outdoor Air Options

A = None
B = Temperature Economizer, Barometric Relief, Standard Leak (W7212 or W7220)
E = Temperature Economizer, Barometric Relief, Standard Leak w/CO₂, (W7212 or W7220)
H = Enthalpy Economizer, Barometric Relief, Standard Leak, (W7212 or W7220)
L = Enthalpy Economizer, Barometric Relief, Standard Leak w/CO₂, (W7212 or W7220)
Q = Motorized 2 Position Damper
U = Temperature Economizer, Barometric Relief, Ultra Low Leak, (W7220)
W = Enthalpy Economizer, Barometric Relief, Ultra Low Leak, (W7220)

Indoor Fan Options

1 = Standard Static Option
2 = Medium Static Option
3 = High Static Option (not available for 558J_08N units)
C = High Static Option with High Efficiency Motor (size 16 only)

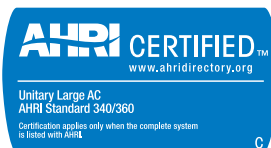

CAPACITY RATINGS

AHRI COOLING RATINGS

558J UNIT	COOLING STAGES	REFRIGERANT CIRCUITS	NOM. CAPACITY (TONS)	NET COOLING CAPACITY (MBH)	TOTAL POWER (kW)	EER	IEER WITH SINGLE SPEED INDOOR FAN MOTOR	IEER WITH 2-SPEED INDOOR FAN MOTOR
07A/G	1	1	6.0	70.0	6.4	11.2	11.4	12.9
08D/K	2	2	7.5	83.0	7.4	11.2	11.7	13.0
09D/K	2	2	8.5	99.0	8.8	11.2	11.7	13.0
12D/K	2	2	10.0	114.0	10.1	11.3	12.2	13.0
14D/K	2	2	12.5	140.0	12.7	11.0	11.2	12.4
16D/K	2	2	15.0	174.0	15.8	11.0	11.7	12.6
08N*	2	1	7.5	88.0	8.0	11.0	12.9	N/A
09N	2	1	8.5	97.0	8.8	11.2	12.9	N/A
12N	2	1	10.0	117.0	10.4	11.2	12.9	N/A

LEGEND

AHRI — Air-Conditioning, Heating and Refrigeration Institute Test Standard
ASHRAE — American Society of Heating, Refrigerating and Air-Conditioning Engineers
EER — Energy Efficiency Ratio
IEER — Integrated Energy Efficiency Ratio
IECC — International Energy Conservation Code
N/A — Not Applicable

* 575V option and Hi-Static Fan option for 08N are not available

NOTES:

1. Rated and certified under AHRI Standard 340/360, as appropriate.
2. Ratings are based on:
Cooling Standard: 80°F (27°C) db, 67°F (19°C) wb indoor.
IEER Standard: A measure that expresses cooling part load EER efficiency for commercial unitary air conditioning and heat pump equipment on the basis of weighted operation at various load capacities.
3. The 558J**D/K units meet the DOE-2018 (Department of Energy), ASHRAE 90.1-2016 and IECC†-2015 minimum efficiency requirements when equipped with the 2-speed indoor fan motor option.
4. The 558J***N rooftops meet the DOE-2018 minimum efficiency requirement without the 2-speed indoor fan motor option.

† IECC is a registered trademark of International Code Council, Inc.



SOUND RATING PERFORMANCE

558J UNIT	COOLING STAGES	OUTDOOR SOUND (dB) AT 60 Hz								
		A-Weighted	63	125	250	500	1000	2000	4000	8000
07A/G	1	78	88.8	81.8	76.9	74.4	73.3	69.8	66.3	62.7
08N	2	82	90.1	82.6	81.0	79.4	77.0	73.0	70.4	66.7
08D/K	2	82	85.8	84.3	80.5	78.7	76.4	72.7	68.3	65.1
09N	2	83	91.2	86.4	81.9	81.0	78.3	73.9	71.4	67.3
09D/K	2	82	88.6	85.0	81.6	79.5	77.4	74.1	71.0	66.3
12N	2	82	88.6	85.0	81.6	79.5	77.4	74.1	71.0	66.3
12D/K	2	82	89.0	83.1	80.5	78.5	75.5	71.6	69.6	69.3
14D/K	2	87	87.0	85.2	84.6	84.9	82.2	78.4	75.3	72.9
16D/K	2	87	87.0	85.2	84.6	84.9	82.2	78.4	75.3	72.9

LEGEND:

dB — Decibel

NOTES:

1. Outdoor sound data is measure in accordance with AHRI standard 270.
2. Measurements are expressed in terms of sound power. Do not compare these values to sound pressure values because sound pressure depends on specific environmental factors which normally do not match individual applications. Sound power values are independent of the environment and therefore more accurate.
3. A-weighted sound ratings filter out very high and very low frequencies, to better approximate the response of "average" human ear. A-weighted measurements for Bryant units are taken in accordance with AHRI standard 270.

CAPACITY RATINGS (CONT)

MINIMUM - MAXIMUM AIRFLOW RATINGS - COOLING AND ELECTRIC HEAT

UNIT	COOLING			ELECTRIC HEATERS		
	Minimum	Minimum 2-Speed Fan Motor (at High Speed)	Minimum 2-Speed Fan Motor (at Low Speed)	Maximum	Minimum	Maximum
558J-07	1800	N/A	N/A	3000	1800	3000
558J-08	2250	2250	1500	3750	2250*	3750
558J-09	2550	2873	1915	4250	2550*	4250
558J-12	3000	3380	2253	5000	3000*	5000
558J-14	3600	4056	2704	6000	3000*	6000
558J-16	4500	5625	3750	7500	4500	7500

* Minimum electric heat CFM exceptions, see table below.

MINIMUM ELECTRIC HEAT CFM EXCEPTIONS

UNIT	UNIT VOLTAGE	HEATER kW	UNIT CONFIGURATION	REQUIRED MINIMUM CFM
558J-12	208/230	42.4	Horizontal	3200
558J-14				
558J-12	208/230	50.0	Horizontal	3200
558J-14				
558J-08	575*	17.0	Horizontal or Vertical	2800
558J-09		34.0		2350
558J-12				
558J-14				

* Not available on 558J-08N units.

COOLING CAPACITIES — 1-CIRCUIT/1-STAGE COOLING, 6 TONS

558J-07 A (RTPF)				AMBIENT TEMPERATURE (F)													
				85			95			105			115				
				EAT (db)			EAT (db)			EAT (db)			EAT (db)				
				75	80	85	75	80	85	75	80	85	75	80	85		
1800 Cfm	EAT (wb)	58	TC	64.9	64.9	73.3	62.1	62.1	70.0	58.9	58.9	66.4	55.6	55.6	62.7		
			SHC	56.6	64.9	73.3	54.1	62.1	70.0	51.4	58.9	66.4	48.5	55.6	62.7		
		62	TC	68.7	68.7	70.3	64.9	64.9	68.5	60.8	60.8	66.4	56.4	56.4	64.0		
			SHC	51.7	61.0	70.3	49.9	59.2	68.5	47.9	57.2	66.4	45.7	54.9	64.0		
		67	TC	75.6	75.6	75.6	71.7	71.7	71.7	67.4	67.4	67.4	62.5	62.5	62.5		
			SHC	42.8	52.2	61.5	41.2	50.5	59.8	39.3	48.6	58.0	37.2	46.5	55.8		
		72	TC	82.6	82.6	82.6	78.5	78.5	78.5	73.7	73.7	73.7	67.8	67.8	67.8		
			SHC	33.5	42.8	52.2	31.9	41.3	50.6	30.0	39.3	48.6	27.8	36.9	45.9		
76	TC	—	87.5	87.5	—	83.3	83.3	—	77.7	77.7	—	70.9	70.9				
	SHC	—	35.0	44.9	—	33.5	43.4	—	31.6	41.5	—	29.3	39.1				
2100 Cfm	EAT (wb)	58	TC	68.9	68.9	77.7	65.9	65.9	74.3	62.5	62.5	70.5	58.7	58.7	66.2		
			SHC	60.1	68.9	77.7	57.4	65.9	74.3	54.5	62.5	70.5	51.2	58.7	66.2		
		62	TC	70.9	70.9	76.9	67.1	67.1	75.0	63.0	63.0	72.5	58.7	58.7	68.7		
			SHC	55.6	66.3	76.9	53.8	64.4	75.0	51.6	62.1	72.5	48.7	58.7	68.7		
		67	TC	77.8	77.8	77.8	73.7	73.7	73.7	69.2	69.2	69.2	64.0	64.0	64.0		
			SHC	45.4	56.1	66.8	43.7	54.4	65.2	41.8	52.5	63.2	39.6	50.2	60.7		
		72	TC	84.5	84.5	84.5	80.3	80.3	80.3	75.1	75.1	75.1	68.8	68.8	68.8		
			SHC	34.5	45.2	55.9	32.9	43.5	54.2	30.9	41.4	52.0	28.5	38.7	48.9		
		76	TC	—	89.2	89.2	—	84.7	84.7	—	78.8	78.8	—	71.6	71.6		
			SHC	—	36.3	47.8	—	34.7	46.0	—	32.6	43.7	—	30.1	40.9		
		2400 Cfm	EAT (wb)	58	TC	72.0	72.0	81.2	68.7	68.7	77.5	65.2	65.2	73.5	61.1	61.1	68.9
					SHC	62.8	72.0	81.2	60.0	68.7	77.5	56.9	65.2	73.5	53.3	61.1	68.9
62	TC			72.8	72.8	82.8	68.9	68.9	80.7	65.2	65.2	76.4	61.2	61.2	71.6		
	SHC			59.1	71.0	82.8	57.2	68.9	80.7	54.1	65.2	76.4	50.7	61.2	71.6		
67	TC			79.4	79.4	79.4	75.2	75.2	75.2	70.5	70.5	70.5	65.1	65.1	65.3		
	SHC			47.7	59.8	71.8	46.0	58.1	70.2	44.0	56.0	68.1	41.6	53.5	65.3		
72	TC			86.0	86.0	86.0	81.6	81.6	81.6	76.1	76.1	76.1	69.6	69.6	69.6		
	SHC			35.3	47.2	59.2	33.7	45.6	57.5	31.7	43.3	55.0	29.1	40.3	51.4		
76	TC			—	90.3	90.3	—	85.7	85.7	—	79.6	79.6	—	72.1	72.1		
	SHC			—	37.3	49.8	—	35.6	48.0	—	33.5	45.6	—	30.8	42.5		
2700 Cfm	EAT (wb)			58	TC	60.3	60.3	74.1	71.1	71.1	80.2	67.4	67.4	76.0	63.0	63.0	71.1
					SHC	46.4	60.3	74.1	62.0	71.1	80.2	58.8	67.4	76.0	55.0	63.0	71.1
		62	TC	65.4	65.4	69.3	71.2	71.2	83.3	67.5	67.5	79.0	63.1	63.1	73.8		
			SHC	41.0	55.1	69.3	59.0	71.2	83.3	55.9	67.5	79.0	52.3	63.1	73.8		
		67	TC	72.7	72.7	72.7	76.3	76.3	76.3	71.5	71.5	72.6	65.8	65.8	69.4		
			SHC	33.8	48.0	62.2	48.2	61.6	74.9	46.1	59.3	72.6	43.5	56.5	69.4		
		72	TC	79.7	79.7	79.7	82.5	82.5	82.5	76.9	76.9	76.9	70.1	70.1	70.1		
			SHC	25.8	40.2	54.6	34.5	47.5	60.5	32.3	45.0	57.7	29.7	41.7	53.8		
		76	TC	—	85.1	85.1	—	86.4	86.4	—	80.2	80.2	—	72.5	72.5		
			SHC	—	33.5	48.4	—	36.5	49.9	—	34.3	47.3	—	31.5	44.0		
		3000 Cfm	EAT (wb)	58	TC	64.9	64.9	78.8	73.1	73.1	82.5	69.2	69.2	78.0	64.5	64.5	72.7
					SHC	51.1	64.9	78.8	63.8	73.1	82.5	60.3	69.2	78.0	56.2	64.5	72.7
62	TC			68.7	68.7	76.5	73.2	73.2	85.7	69.2	69.2	81.0	64.5	64.5	75.5		
	SHC			45.5	61.0	76.5	60.7	73.2	85.7	57.4	69.2	81.0	53.5	64.5	75.5		
67	TC			75.6	75.6	75.6	77.2	77.2	79.4	72.2	72.2	76.8	66.3	66.3	73.0		
	SHC			36.6	52.2	67.7	50.2	64.8	79.4	48.0	62.4	76.8	45.1	59.1	73.0		
72	TC			82.6	82.6	82.6	83.3	83.3	83.3	77.5	77.5	77.5	70.5	70.5	70.5		
	SHC			27.2	42.8	58.5	35.1	49.2	63.3	32.9	46.6	60.3	30.2	43.0	55.9		
76	TC			—	87.5	87.5	—	86.9	86.9	—	80.6	80.6	—	72.8	72.8		
	SHC			—	35.0	51.5	—	37.3	51.6	—	35.0	48.9	—	32.1	45.3		

LEGEND
 — Do not operate
Cfm — Cubic feet per minute (supply air)
EAT (db) — Entering Air Temperature (dry bulb)
EAT (wb) — Entering Air Temperature (wet bulb)
SHC — Sensible Heat Capacity (1000 Btuh) Gross
TC — Total Capacity (1000 Btuh) Gross

NOTE: See Minimum-Maximum Airflow Ratings table on page 6. Do not operate outside these limits.

CAPACITY RATINGS (CONT)

COOLING CAPACITIES — 1-CIRCUIT/1-STAGE COOLING, 6 TONS (cont)

Temp (F) Air Entering Condenser (Edb)		558J 07 (6 TON) - UNIT WITH PERFECT HUMIDITY IN SUBCOOLING MODE								
		Air Entering Evaporator - CFM								
		4,500			6,000			7,500		
		Air Entering Evaporator - Ewb (F)								
		72	67	62	72	67	62	72	67	62
75	TC	208.50	190.60	172.60	229.20	208.60	188.10	247.80	224.90	202.00
	SHC	94.00	114.50	135.00	104.50	125.20	145.90	113.00	133.80	154.60
	kW	13.42	13.05	12.70	13.60	13.21	12.80	13.82	13.36	13.15
85	TC	198.30	180.70	163.00	214.90	194.80	174.60	229.80	207.40	185.10
	SHC	74.10	99.60	125.10	85.20	110.90	136.70	94.10	120.00	145.90
	kW	14.79	14.42	14.10	14.97	14.58	14.20	15.19	14.73	14.51
95	TC	188.20	170.80	153.40	200.60	180.90	161.10	211.90	190.00	168.10
	SHC	54.40	84.80	115.30	65.90	96.70	127.50	75.10	106.20	137.20
	kW	16.23	15.86	15.50	16.41	16.02	15.60	16.63	16.17	15.95
105	TC	178.10	160.90	143.80	186.40	167.00	147.70	193.90	172.50	151.20
	SHC	34.60	70.00	105.40	46.50	82.40	118.20	56.10	92.30	128.50
	kW	17.47	17.10	16.80	17.65	17.26	16.90	17.87	17.41	17.25
115	TC	167.90	151.10	134.20	172.10	153.20	134.20	175.90	155.10	134.50
	SHC	14.80	55.20	95.60	27.20	68.10	109.00	37.10	78.50	119.80
	kW	18.87	18.50	18.20	19.05	18.66	18.30	19.27	18.81	18.55

558J 07 (6 TONS) – UNIT WITH PERFECT HUMIDITY SYSTEM IN HOT GAS REHEAT MODE

Temp (F) Air Entering Condenser (Edb)		Air Entering Evaporator – CFM								
		75 dry bulb			75 dry bulb			75 dry bulb		
		62.5 wet bulb (50% relative)			64 wet bulb (55% relative)			65.3 wet bulb (60% relative)		
		2100	2400	2700	2100	2400	2700	1750	2000	2700
80	TC	16.7	19.8	22.5	18.8	21.9	24.7	16.2	19.4	26.7
	SHC	0.6	0.6	0.6	-0.4	-0.4	-0.4	-1.3	-1.3	-1.3
	kW	4.0	4.0	4.0	4.0	4.0	4.0	4.0	4.0	4.0
75	TC	17.7	20.6	23.1	19.6	22.6	25.3	17.3	20.3	27.1
	SHC	0.6	0.6	0.6	-0.3	-0.3	-0.3	-1.2	-1.2	-1.2
	kW	4.0	4.0	4.0	4.0	4.0	4.0	4.0	4.0	4.0
70	TC	18.6	21.3	23.7	20.5	23.3	25.8	18.3	21.1	27.6
	SHC	0.7	0.7	0.7	-0.2	-0.2	-0.2	-1.0	-1.0	-1.0
	kW	4.0	4.0	4.0	4.1	4.1	4.1	4.1	4.1	4.1
60	TC	20.5	22.9	25.0	22.2	24.7	26.8	20.4	22.8	28.5
	SHC	0.7	0.7	0.7	0.0	0.0	0.0	-0.7	-0.7	-0.7
	kW	4.1	4.1	4.1	4.1	4.1	4.1	4.1	4.1	4.1
50	TC	22.4	24.4	26.2	24.0	26.0	27.9	22.4	24.5	29.3
	SHC	0.8	0.8	0.8	0.1	0.1	0.1	-0.4	-0.4	-0.4
	kW	4.1	4.1	4.1	4.1	4.1	4.1	4.2	4.2	4.2
40	TC	24.3	25.9	27.4	25.7	27.4	28.9	24.5	26.3	30.2
	SHC	0.8	0.8	0.8	0.3	0.3	0.3	-0.1	-0.1	-0.1
	kW	4.1	4.1	4.1	4.2	4.2	4.2	4.2	4.2	4.2

LEGEND

Edb — Entering Dry-Bulb
Ewb — Entering Wet-Bulb
kW — Compressor Motor Power Input
ldb — Leaving Dry-Bulb
lwb — Leaving Wet-Bulb
SHC — Sensible Heat Capacity (1000 Btuh) Gross
TC — Total Capacity (1000 Btuh) Gross

NOTES:

- Direct interpolation is permissible. Do not extrapolate.
- The following formulas may be used:

$$t_{ldb} = t_{edb} - \frac{\text{sensible capacity (Btuh)}}{1.10 \times \text{cfm}}$$

t_{lwb} = Wet-bulb temperature corresponding to enthalpy of air leaving evaporator coil (h_{lwb})

$$h_{lwb} = h_{ewb} - \frac{\text{total capacity (Btuh)}}{4.5 \times \text{cfm}}$$

Where: h_{ewb} = Enthalpy of air entering evaporator coil

COOLING CAPACITIES — 2-CIRCUIT/2-STAGE COOLING, 7.5 TONS

558J-08D (RTPF and Novation®)				AMBIENT TEMPERATURE (F)												
				85			95			105			115			
				EAT (db)			EAT (db)			EAT (db)			EAT (db)			
				75	80	85	75	80	85	75	80	85	75	80	85	
2250 Cfm	EAT (wb)	58	TC	77.4	77.4	87.8	73.8	73.8	83.8	70.1	70.1	79.5	66.0	66.0	74.9	
			SHC	66.9	77.4	87.8	63.9	73.8	83.8	60.6	70.1	79.5	57.1	66.0	74.9	
		62	TC	82.2	82.2	83.9	77.5	77.5	81.7	72.6	72.6	79.2	67.3	67.3	76.4	
			SHC	60.8	72.4	83.9	58.6	70.1	81.7	56.3	67.7	79.2	53.6	65.0	76.4	
		67	TC	90.1	90.1	90.1	86.0	86.0	86.0	81.4	81.4	81.4	75.9	75.9	75.9	
			SHC	50.2	61.8	73.3	48.5	60.1	71.6	46.5	58.1	69.7	44.2	55.8	67.4	
	72	TC	98.0	98.0	98.0	94.0	94.0	94.0	89.5	89.5	89.5	84.3	84.3	84.3		
		SHC	39.1	50.7	62.4	37.5	49.2	60.9	35.8	47.5	59.2	33.8	45.5	57.2		
	76	TC	—	104.3	104.3	—	100.4	100.4	—	95.9	95.9	—	90.7	90.7		
		SHC	—	41.7	54.0	—	40.3	52.7	—	38.7	51.0	—	36.8	49.0		
	2625 Cfm	EAT (wb)	58	TC	82.1	82.1	93.2	78.4	78.4	89.0	74.4	74.4	84.4	70.0	70.0	79.5
				SHC	71.0	82.1	93.2	67.8	78.4	89.0	64.3	74.4	84.4	60.6	70.0	79.5
62			TC	84.9	84.9	91.8	80.4	80.4	89.5	75.4	75.4	86.7	70.2	70.2	82.9	
			SHC	65.4	78.6	91.8	63.2	76.3	89.5	60.6	73.7	86.7	57.6	70.2	82.9	
67			TC	92.5	92.5	92.5	88.3	88.3	88.3	83.6	83.6	83.6	78.3	78.3	78.3	
			SHC	53.0	66.3	79.5	51.3	64.6	78.0	49.4	62.8	76.1	47.2	60.6	73.9	
72		TC	100.4	100.4	100.4	96.4	96.4	96.4	91.7	91.7	91.7	86.4	86.4	86.4		
		SHC	40.2	53.5	66.7	38.7	52.0	65.3	36.9	50.3	63.7	35.0	48.4	61.8		
76		TC	—	106.5	106.5	—	102.6	102.6	—	98.0	98.0	—	92.7	92.7		
		SHC	—	43.3	57.6	—	41.8	55.9	—	40.2	54.1	—	38.4	52.2		
3000 Cfm		EAT (wb)	58	TC	85.7	85.7	97.3	82.2	82.2	93.3	78.0	78.0	88.6	73.5	73.5	83.4
				SHC	74.1	85.7	97.3	71.1	82.2	93.3	67.5	78.0	88.6	63.6	73.5	83.4
	62		TC	86.9	86.9	98.7	82.8	82.8	96.4	78.2	78.2	92.3	73.6	73.6	86.9	
			SHC	69.3	84.0	98.7	67.2	81.8	96.4	64.1	78.2	92.3	60.3	73.6	86.9	
	67		TC	94.3	94.3	94.3	90.1	90.1	90.1	85.2	85.2	85.2	79.8	79.8	80.1	
			SHC	55.6	70.5	85.4	54.0	68.9	83.9	52.1	67.1	82.2	49.9	65.0	80.1	
	72	TC	102.2	102.2	102.2	98.1	98.1	98.1	93.3	93.3	93.3	87.9	87.9	87.9		
		SHC	41.2	56.0	70.7	39.7	54.6	69.5	38.0	53.0	68.0	36.0	51.1	66.2		
	76	TC	—	108.1	108.1	—	104.2	104.2	—	99.5	99.5	—	94.2	94.2		
		SHC	—	44.5	60.2	—	43.2	58.7	—	41.6	57.0	—	39.8	55.2		
	3375 Cfm	EAT (wb)	58	TC	88.5	88.5	100.4	85.0	85.0	96.4	81.0	81.0	92.0	76.5	76.5	86.8
				SHC	76.5	88.5	100.4	73.5	85.0	96.4	70.1	81.0	92.0	66.1	76.5	86.8
62			TC	88.9	88.9	103.9	85.1	85.1	100.4	81.1	81.1	95.7	76.5	76.5	90.3	
			SHC	72.3	88.1	103.9	69.7	85.1	100.4	66.5	81.1	95.7	62.7	76.5	90.3	
67			TC	95.8	95.8	95.8	91.5	91.5	91.5	86.6	86.6	87.9	81.1	81.1	85.8	
			SHC	58.0	74.4	90.9	56.4	73.0	89.6	54.6	71.3	87.9	52.4	69.1	85.8	
72		TC	103.6	103.6	103.6	99.4	99.4	99.4	94.6	94.6	94.6	89.1	89.1	89.1		
		SHC	42.0	58.3	74.5	40.6	57.0	73.4	38.9	55.5	72.0	37.0	53.7	70.3		
76		TC	—	109.2	109.2	—	105.4	105.4	—	100.7	100.7	—	95.3	95.3		
		SHC	—	45.6	62.6	—	44.4	61.3	—	42.8	59.7	—	41.0	58.0		
3750 Cfm		EAT (wb)	58	TC	90.8	90.8	103.0	87.3	87.3	99.1	83.3	83.3	94.5	78.8	78.8	89.4
				SHC	78.5	90.8	103.0	75.5	87.3	99.1	72.0	83.3	94.5	68.2	78.8	89.4
	62		TC	90.9	90.9	107.2	87.4	87.4	103.1	83.3	83.3	98.4	78.9	78.9	93.1	
			SHC	74.5	90.9	107.2	71.6	87.4	103.1	68.3	83.3	98.4	64.7	78.9	93.1	
	67		TC	97.0	97.0	97.0	92.6	92.6	95.1	87.6	87.6	93.4	82.1	82.1	91.2	
			SHC	60.3	78.2	96.2	58.8	76.9	95.1	56.9	75.2	93.4	54.8	73.0	91.2	
	72	TC	104.7	104.7	104.7	100.5	100.5	100.5	95.6	95.6	95.6	90.1	90.1	90.1		
		SHC	42.9	60.5	78.1	41.4	59.3	77.1	39.8	57.8	75.9	37.9	56.1	74.3		
	76	TC	—	110.2	110.2	—	106.2	106.2	—	101.6	101.6	—	96.1	96.1		
		SHC	—	46.7	64.8	—	45.4	63.6	—	44.0	62.3	—	42.2	60.6		

LEGEND
 — Do not operate
Cfm — Cubic feet per minute (supply air)
EAT (db) — Entering Air Temperature (dry bulb)
EAT (wb) — Entering Air Temperature (wet bulb)
SHC — Sensible Heat Capacity (1000 Btuh) Gross
TC — Total Capacity (1000 Btuh) Gross

NOTE: See Minimum-Maximum Airflow Ratings table on page 6. Do not operate outside these limits.

CAPACITY RATINGS (CONT)

COOLING CAPACITIES — 2-CIRCUIT/2-STAGE COOLING, 7.5 TONS (cont)

558J 08 COOLING CAPACITIES, RTPF UNIT WITH PERFECT HUMIDITY SYSTEM IN SUBCOOLING MODE										
Temp (F) Air Entering Condenser (Edb)		AIR ENTERING EVAPORATOR - CFM								
		2250/0.05			3000/0.07			3750/0.09		
		Air Entering Evaporator - Ewb (F)								
		72	67	62	72	67	62	72	67	62
75	TC	103.05	93.02	83.60	109.77	99.52	90.08	114.01	103.69	95.19
	SHC	43.66	55.34	67.09	50.99	66.29	81.31	57.49	76.27	92.20
	kW	4.90	4.83	4.77	4.82	4.88	4.96	4.99	4.91	4.85
85	TC	95.39	85.83	76.88	101.59	91.89	82.95	105.53	95.76	87.77
	SHC	36.42	48.47	60.60	43.24	58.99	74.40	49.44	68.68	84.90
	kW	5.49	5.42	5.36	5.40	5.47	5.54	5.58	5.50	5.44
95	TC	87.48	78.44	69.97	93.21	84.05	75.61	96.84	87.63	80.14
	SHC	28.98	41.46	53.97	35.32	51.53	67.34	41.21	60.92	77.41
	kW	6.16	6.09	6.03	6.08	6.14	6.21	6.24	6.17	6.11
105	TC	79.35	70.83	62.84	84.57	75.96	68.04	87.88	79.23	72.26
	SHC	21.34	34.26	47.18	27.17	43.86	60.08	32.73	52.95	69.70
	kW	6.93	6.86	6.81	6.85	6.91	6.97	7.00	6.93	6.88
115	TC	70.87	62.89	55.42	75.58	67.54	60.15	78.56	70.51	64.06
	SHC	13.40	26.79	40.14	18.70	35.89	52.54	23.94	44.68	61.67
	kW	7.79	7.74	7.69	7.73	7.78	7.83	7.86	7.80	7.76

558J 08 COOLING CAPACITIES, RTPF UNIT WITH PERFECT HUMIDITY SYSTEM IN HOT GAS REHEAT MODE										
Temp (F) Air Entering Condenser (Edb)		Air Entering Evaporator - Ewb (F)								
		75 Dry Bulb			75 Dry Bulb			75 Dry Bulb		
		62.5 Wet Bulb			64 Wet Bulb			65.3 Wet Bulb		
		(50% Relative)			(56% Relative)			(60% Relative)		
		Air Entering Evaporator - CFM								
		2250	3000	3750	2250	3000	3750	2250	3000	3750
80	TC	27.60	32.75	30.19	40.09	39.43	37.73	45.06	45.25	44.25
	SHC	-3.12	5.20	6.71	3.75	5.24	6.75	3.77	5.26	6.78
	kW	4.56	4.51	4.46	4.63	4.60	4.56	4.70	4.67	4.64
75	TC	35.40	33.78	31.20	41.14	40.51	38.80	46.15	46.37	45.38
	SHC	4.67	6.17	7.69	4.71	6.21	7.73	4.74	6.24	7.76
	kW	4.41	4.36	4.39	4.41	4.36	4.36	4.41	4.39	4.36
70	TC	36.36	34.71	32.18	42.10	41.47	39.77	47.08	47.31	46.32
	SHC	5.63	7.14	8.66	5.67	7.18	8.71	5.70	7.21	8.74
	kW	4.43	4.49	4.41	4.44	4.40	4.39	4.49	4.47	4.44
60	TC	38.25	36.64	34.15	43.97	43.37	41.72	48.98	49.22	48.26
	SHC	7.56	9.09	10.62	7.60	9.13	10.66	7.62	9.15	10.69
	kW	4.56	4.55	4.43	4.57	4.53	4.46	4.56	4.55	4.50
50	TC	40.15	38.60	36.14	45.95	45.37	43.73	50.57	50.97	49.56
	SHC	9.48	11.03	12.58	9.52	11.07	12.62	9.54	11.10	12.64
	kW	4.63	4.52	4.38	4.45	4.41	4.33	5.25	4.91	5.60
40	TC	42.18	40.62	38.11	47.80	47.25	45.43	52.65	52.75	51.83
	SHC	11.41	12.98	14.54	11.45	13.02	14.58	11.47	13.04	14.60
	kW	4.32	4.37	4.37	4.65	4.60	4.89	4.96	5.20	5.12

LEGEND

Edb — Entering Dry-Bulb
Ewb — Entering Wet-Bulb
kW — Compressor Motor Power Input
ldb — Leaving Dry-Bulb
lwb — Leaving Wet-Bulb
SHC — Sensible Heat Capacity (1000 Btuh) Gross
TC — Total Capacity (1000 Btuh) Gross

NOTES:

1. Direct interpolation is permissible. Do not extrapolate.
2. The following formulas may be used:

$$t_{db} = t_{edb} - \frac{\text{sensible capacity (Btuh)}}{1.10 \times \text{cfm}}$$

$$t_{wb} = \text{Wet-bulb temperature corresponding to enthalpy of air leaving evaporator coil } (h_{lwb})$$

$$h_{lwb} = h_{ewb} - \frac{\text{total capacity (Btuh)}}{4.5 \times \text{cfm}}$$

Where: h_{ewb} = Enthalpy of air entering evaporator coil

COOLING CAPACITIES — 1-CIRCUIT 2-STAGE COOLING, 7.5 TONS

558J-08N* (RTPF)			AMBIENT TEMPERATURE (F)													
			85			95			105			115				
			EAT (db)			EAT (db)			EAT (db)			EAT (db)				
			75	80	85	75	80	85	75	80	85	75	80	85		
2250 Cfm	EAT (wb)	58	TC	79.6	79.6	87.7	76.2	76.2	86.4	73.1	73.1	82.8	69.5	69.5	78.8	
			SHC	67.5	77.6	87.7	66.0	76.2	86.4	63.2	73.0	82.8	60.2	69.5	78.8	
		62	TC	85.6	85.6	85.6	81.6	81.6	81.6	77.3	77.3	78.5	72.6	72.6	76.4	
			SHC	60.8	71.5	82.1	59.0	69.7	80.4	57.0	67.8	78.5	54.9	65.7	76.4	
		67	TC	94.5	94.5	94.5	90.0	90.0	90.0	85.2	85.2	85.2	80.0	80.0	80.0	
			SHC	50.5	61.0	71.5	48.6	59.2	69.9	46.7	57.3	68.0	44.6	55.3	66.1	
	72	TC	104.2	104.2	104.2	99.3	99.3	99.3	94.0	94.0	94.0	88.2	88.2	88.2		
		SHC	40.3	50.2	60.0	38.4	48.4	58.5	36.3	46.6	56.8	34.1	44.5	55.0		
	76	TC	—	112.4	112.4	—	107.3	107.3	—	101.6	101.6	—	95.3	95.3		
		SHC	—	41.6	54.0	—	39.2	51.6	—	37.2	49.6	—	35.5	47.9		
	2625 Cfm	EAT (wb)	58	TC	84.7	84.7	92.8	80.9	80.9	91.6	77.4	77.4	87.7	73.5	73.5	83.3
				SHC	71.6	82.2	92.8	70.1	80.9	91.6	67.0	77.4	87.7	63.7	73.5	83.3
62			TC	88.7	88.7	90.4	84.4	84.4	88.6	79.8	79.8	86.3	74.8	74.8	83.6	
			SHC	65.7	78.0	90.4	63.8	76.2	88.6	61.7	74.0	86.3	59.2	71.4	83.6	
67			TC	97.6	97.6	97.6	92.9	92.9	92.9	87.8	87.8	87.8	82.3	82.3	82.3	
			SHC	53.8	66.1	78.4	51.9	64.2	76.6	49.9	62.3	74.7	47.7	60.2	72.7	
72		TC	107.5	107.5	107.5	102.3	102.3	102.3	96.7	96.7	96.7	90.6	90.6	90.6		
		SHC	41.7	53.5	65.3	39.8	51.7	63.7	37.7	49.8	61.9	35.5	47.7	60.0		
76		TC	—	116.1	116.1	—	110.4	110.4	—	104.3	104.3	—	97.7	97.7		
		SHC	—	42.7	57.3	—	41.2	55.8	—	39.4	48.5	—	37.4	48.3		
3000 Cfm		EAT (wb)	58	TC	87.7	87.7	99.3	84.3	84.3	95.5	80.5	80.5	91.2	76.4	76.4	86.5
				SHC	76.0	87.7	99.3	73.1	84.3	95.5	69.8	80.5	91.2	66.2	76.4	86.5
	62		TC	90.8	90.8	97.0	86.3	86.3	94.8	81.6	81.6	92.1	76.8	76.8	88.4	
			SHC	69.6	83.3	97.0	67.5	81.1	94.8	65.1	78.6	92.1	62.2	75.3	88.4	
	67		TC	99.8	99.8	99.8	94.9	94.9	94.9	89.6	89.6	89.6	83.8	83.8	83.8	
			SHC	56.5	70.3	84.0	54.6	68.4	82.3	52.5	66.4	80.3	50.3	64.3	78.2	
	72	TC	109.8	109.8	109.8	104.3	104.3	104.3	98.5	98.5	98.5	92.1	92.1	92.1		
		SHC	42.9	56.3	69.6	40.9	54.4	67.9	38.8	52.5	66.1	36.6	50.3	64.1		
	76	TC	—	118.4	118.4	—	112.5	112.5	—	106.1	106.1	—	99.3	99.3		
		SHC	—	44.6	61.1	—	42.8	54.0	—	40.9	53.1	—	38.9	51.7		
	3375 Cfm	EAT (wb)	58	TC	91.2	91.2	103.3	87.6	87.6	99.2	83.6	83.6	94.6	79.2	79.2	89.7
				SHC	79.2	91.2	103.3	76.0	87.6	99.2	72.5	83.6	94.6	68.7	79.2	89.7
62			TC	92.8	92.8	103.4	88.4	88.4	100.6	84.0	84.0	96.7	79.9	79.9	90.6	
			SHC	73.5	88.5	103.4	71.0	85.8	100.6	68.1	82.4	96.7	64.0	77.3	90.6	
67			TC	101.8	101.8	101.8	96.7	96.7	96.7	91.2	91.2	91.2	85.2	85.2	85.2	
			SHC	59.4	74.9	90.3	57.5	73.0	88.5	55.4	70.9	86.5	53.1	68.7	84.3	
72		TC	111.9	111.9	111.9	106.2	106.2	106.2	100.1	100.1	100.1	93.5	93.5	93.5		
		SHC	44.2	59.3	74.4	42.2	57.4	72.6	40.0	55.4	70.7	37.8	53.2	68.7		
76		TC	—	120.5	120.5	—	114.4	114.4	—	107.8	107.8	—	100.7	100.7		
		SHC	—	46.4	59.4	—	44.5	58.3	—	42.6	56.9	—	40.5	55.2		
3750 Cfm		EAT (wb)	58	TC	93.9	93.9	106.3	90.1	90.1	101.9	85.8	85.8	97.2	81.2	81.2	92.0
				SHC	81.5	93.9	106.3	78.2	90.1	101.9	74.5	85.8	97.2	70.5	81.2	92.0
	62		TC	94.5	94.5	107.9	90.2	90.2	105.9	86.7	86.7	97.9	81.5	81.5	94.8	
			SHC	76.2	92.1	107.9	74.3	90.1	105.9	69.3	83.6	97.9	66.6	80.7	94.8	
	67		TC	103.3	103.3	103.3	98.0	98.0	98.0	92.3	92.3	92.3	86.2	86.2	89.3	
			SHC	61.9	78.7	95.6	59.9	76.8	93.7	57.8	74.7	91.6	55.5	72.4	89.3	
	72	TC	113.3	113.3	113.3	107.5	107.5	107.5	101.3	101.3	101.3	94.5	94.5	94.5		
		SHC	45.2	61.8	78.3	43.2	59.9	76.5	41.1	57.8	74.6	38.8	55.6	72.5		
	76	TC	—	122.0	122.0	—	115.8	115.8	—	109.0	109.0	—	101.7	101.7		
		SHC	—	47.8	62.8	—	45.9	61.4	—	44.0	59.8	—	41.8	58.1		

LEGEND
 — Do not operate
 Cfm — Cubic feet per minute (supply air)
 EAT (db) — Entering Air Temperature (dry bulb)
 EAT (wb) — Entering Air Temperature (wet bulb)
 SHC — Sensible Heat Capacity (1000 Btuh) Gross
 TC — Total Capacity (1000 Btuh) Gross

* Not available in 575V models or 208/230/3/60 and 460/3/60 models with high static indoor fan motor.

NOTE: See Minimum-Maximum Airflow Ratings table on page 6. Do not operate outside these limits.

CAPACITY RATINGS (CONT)

COOLING CAPACITIES — 2-CIRCUIT/2-STAGE COOLING, 8.5 TONS

558J-09D (RTPF)			AMBIENT TEMPERATURE (F)													
			85			95			105			115				
			EAT (db)			EAT (db)			EAT (db)			EAT (db)				
			75	80	85	75	80	85	75	80	85	75	80	85		
2550 Cfm	EAT (wb)	58	TC	89.7	89.7	101.6	85.2	85.2	96.5	79.6	79.6	90.1	73.8	73.8	83.6	
			SHC	77.8	89.7	101.6	73.9	85.2	96.5	69.0	79.6	90.1	64.0	73.8	83.6	
		62	TC	94.3	94.3	97.9	88.7	88.7	95.2	81.3	81.3	91.5	74.3	74.3	86.5	
			SHC	71.0	84.4	97.9	68.2	81.7	95.2	64.7	78.1	91.5	60.6	73.6	86.5	
		67	TC	105.0	105.0	105.0	99.3	99.3	99.3	92.2	92.2	92.2	84.1	84.1	84.1	
			SHC	59.0	72.6	86.1	56.6	70.1	83.7	53.6	67.1	80.7	50.3	63.8	77.3	
	72	TC	115.9	115.9	115.9	110.4	110.4	110.4	104.2	104.2	104.2	96.0	96.0	96.0		
		SHC	46.4	60.0	73.6	44.3	57.9	71.5	41.9	55.5	69.1	38.8	52.4	65.9		
	76	TC	—	123.7	123.7	—	118.3	118.3	—	112.4	112.4	—	105.7	105.7		
		SHC	—	49.3	63.3	—	47.3	61.4	—	45.3	59.3	—	42.9	56.7		
	2975 Cfm	EAT (wb)	58	TC	95.3	95.3	107.9	90.7	90.7	102.7	84.8	84.8	96.1	78.7	78.7	89.1
				SHC	82.6	95.3	107.9	78.6	90.7	102.7	73.5	84.8	96.1	68.2	78.7	89.1
62			TC	97.9	97.9	107.8	92.1	92.1	104.7	85.4	85.4	99.4	78.8	78.8	92.8	
			SHC	76.7	92.2	107.8	73.9	89.3	104.7	69.6	84.5	99.4	64.8	78.8	92.8	
67			TC	108.5	108.5	108.5	102.6	102.6	102.6	95.4	95.4	95.4	86.9	86.9	86.9	
			SHC	62.8	78.4	94.1	60.4	76.0	91.7	57.4	73.1	88.8	54.0	69.7	85.3	
72		TC	119.1	119.1	119.1	113.5	113.5	113.5	107.2	107.2	107.2	99.2	99.2	99.2		
		SHC	47.9	63.5	79.2	45.8	61.5	77.1	43.5	59.2	74.9	40.6	56.3	72.0		
76		TC	—	126.4	126.4	—	120.8	120.8	—	114.8	114.8	—	108.2	108.2		
		SHC	—	51.1	67.4	—	49.2	65.3	—	47.0	63.0	—	44.8	60.7		
3400 Cfm		EAT (wb)	58	TC	100.0	100.0	113.3	95.2	95.2	107.9	89.3	89.3	101.1	82.9	82.9	93.9
				SHC	86.7	100.0	113.3	82.6	95.2	107.9	77.4	89.3	101.1	71.8	82.9	93.9
	62		TC	101.1	101.1	115.8	95.7	95.7	111.7	89.4	89.4	105.3	83.0	83.0	97.7	
			SHC	81.5	98.7	115.8	78.2	94.9	111.7	73.5	89.4	105.3	68.2	83.0	97.7	
	67		TC	111.1	111.1	111.1	105.1	105.1	105.1	97.8	97.8	97.8	89.1	89.1	93.0	
			SHC	66.2	83.9	101.6	63.9	81.6	99.3	61.0	78.7	96.5	57.5	75.3	93.0	
	72	TC	121.3	121.3	121.3	115.6	115.6	115.6	109.4	109.4	109.4	101.5	101.5	101.5		
		SHC	49.2	66.7	84.3	47.1	64.7	82.3	44.9	62.5	80.2	42.1	59.9	77.7		
	76	TC	—	128.3	128.3	—	122.6	122.6	—	116.3	116.3	—	109.7	109.7		
		SHC	—	52.7	70.7	—	50.7	68.6	—	48.6	66.4	—	46.4	64.2		
	3825 Cfm	EAT (wb)	58	TC	104.0	104.0	117.8	99.1	99.1	112.3	93.2	93.2	105.5	86.5	86.5	97.9
				SHC	90.2	104.0	117.8	86.0	99.1	112.3	80.8	93.2	105.5	75.0	86.5	97.9
62			TC	104.2	104.2	122.7	99.3	99.3	116.9	93.3	93.3	109.8	86.6	86.6	101.9	
			SHC	85.7	104.2	122.7	81.7	99.3	116.9	76.7	93.3	109.8	71.2	86.6	101.9	
67			TC	113.1	113.1	113.1	107.1	107.1	107.1	99.9	99.9	103.8	91.0	91.0	100.3	
			SHC	69.4	89.1	108.8	67.1	86.8	106.5	64.3	84.1	103.8	60.9	80.6	100.3	
72		TC	123.0	123.0	123.0	117.2	117.2	117.2	110.9	110.9	110.9	103.3	103.3	103.3		
		SHC	50.3	69.7	89.0	48.3	67.7	87.1	46.1	65.6	85.2	43.5	63.3	83.0		
76		TC	—	129.7	129.7	—	124.0	124.0	—	117.5	117.5	—	110.8	110.8		
		SHC	—	54.0	73.7	—	52.1	71.7	—	50.0	69.5	—	47.8	67.4		
4250 Cfm		EAT (wb)	58	TC	107.4	107.4	121.7	102.5	102.5	116.1	96.5	96.5	109.3	89.5	89.5	101.4
				SHC	93.1	107.4	121.7	88.9	102.5	116.1	83.7	96.5	109.3	77.6	89.5	101.4
	62		TC	107.5	107.5	126.6	102.6	102.6	120.8	96.6	96.6	113.7	89.6	89.6	105.5	
			SHC	88.4	107.5	126.6	84.4	102.6	120.8	79.5	96.6	113.7	73.7	89.6	105.5	
	67		TC	114.7	114.7	115.6	108.7	108.7	113.5	101.7	101.7	110.8	92.6	92.6	107.2	
			SHC	72.5	94.0	115.6	70.2	91.8	113.5	67.5	89.2	110.8	64.0	85.6	107.2	
	72	TC	124.3	124.3	124.3	118.5	118.5	118.5	112.1	112.1	112.1	104.7	104.7	104.7		
		SHC	51.3	72.4	93.4	49.3	70.5	91.7	47.2	68.5	89.9	44.7	66.4	88.1		
	76	TC	—	130.7	130.7	—	125.0	125.0	—	118.5	118.5	—	111.6	111.6		
		SHC	—	55.3	76.5	—	53.5	74.6	—	51.3	72.4	—	49.2	70.3		

LEGEND

- Do not operate
- Cfm — Cubic feet per minute (supply air)
- EAT (db) — Entering Air Temperature (dry bulb)
- EAT (wb) — Entering Air Temperature (wet bulb)
- SHC — Sensible Heat Capacity (1000 Btuh) Gross
- TC — Total Capacity (1000 Btuh) Gross

NOTE: See Minimum-Maximum Airflow Ratings on page 6. Do not operate outside these limits.

COOLING CAPACITIES — 2-CIRCUIT/2-STAGE COOLING, 8.5 TONS (cont)

558J 09 COOLING CAPACITIES, RTPF UNIT WITH PERFECT HUMIDITY SYSTEM IN SUBCOOLING MODE

Temp (F) Air Entering Condenser (Edb)		Air Entering Evaporator - CFM								
		2550/0.04			3400/0.05			4250/0.07		
		Air Entering Evaporator - Ewb (F)								
		72	67	62	72	67	62	72	67	62
75	TC	119.20	107.40	96.40	127.00	115.00	103.90	131.90	119.80	109.50
	SHC	50.60	63.90	77.40	59.20	76.70	94.20	66.80	88.40	108.20
	kW	5.67	5.57	5.47	5.54	5.63	5.74	5.79	5.68	5.59
85	TC	110.40	99.20	88.80	117.60	106.30	95.80	122.20	110.80	101.10
	SHC	42.40	56.20	70.10	50.40	68.50	86.40	57.70	79.90	99.90
	kW	6.33	6.23	6.14	6.20	6.30	6.40	6.45	6.34	6.25
95	TC	101.40	90.80	80.90	108.10	97.30	87.40	112.30	101.50	92.40
	SHC	34.00	48.20	62.60	41.50	60.00	78.40	48.40	71.10	91.50
	kW	7.08	6.99	6.90	6.96	7.05	7.16	7.20	7.09	7.01
105	TC	92.00	82.10	72.70	98.20	88.10	78.70	102.10	91.90	83.40
	SHC	25.30	40.10	54.90	32.20	51.30	70.20	38.80	62.10	82.70
	kW	7.94	7.85	7.77	7.83	7.91	8.01	8.06	7.95	7.87
115	TC	82.40	73.00	64.20	88.00	78.50	69.70	91.50	81.90	74.10
	SHC	16.40	31.60	47.00	22.70	42.40	61.70	28.90	52.70	73.50
	kW	8.92	8.84	8.77	8.82	8.89	8.98	9.02	8.93	8.86

558J 09 COOLING CAPACITIES, RTPF UNIT WITH PERFECT HUMIDITY SYSTEM IN HOT GAS REHEAT MODE

Temp (F) Air Entering Condenser (Edb)		Air Entering Evaporator - Ewb (F)								
		75 Dry Bulb			75 Dry Bulb			75 Dry Bulb		
		62.5 Wet Bulb			64 Wet Bulb			65.3 Wet Bulb		
		(50% Relative)			(56% Relative)			(60% Relative)		
		Air Entering Evaporator - Cfm								
		2550	3400	4250	2550	3400	4250	2550	3400	4250
80	TC	37.61	33.13	26.77	44.74	41.60	36.46	50.96	48.99	44.93
	SHC	-0.52	-0.63	-0.73	-0.46	-0.57	-0.67	-0.42	-0.53	-0.62
	kW	5.88	5.68	5.44	6.13	5.97	5.76	6.35	6.24	6.06
75	TC	38.71	34.24	27.86	45.84	42.73	37.59	52.05	50.11	46.06
	SHC	0.45	0.34	0.25	0.50	0.40	0.31	0.54	0.44	0.36
	kW	5.68	5.47	5.22	5.94	5.78	5.56	6.18	6.07	5.88
70	TC	39.70	35.25	28.83	46.80	43.70	38.59	52.97	51.04	47.02
	SHC	1.41	1.32	1.23	1.47	1.37	1.29	1.50	1.41	1.34
	kW	5.65	5.42	5.24	5.97	5.79	5.53	6.26	6.13	5.91
60	TC	41.77	37.33	30.76	48.86	45.80	40.71	55.00	53.10	49.12
	SHC	3.34	3.26	3.18	3.40	3.32	3.25	3.43	3.36	3.29
	kW	5.42	5.15	5.17	5.80	5.59	5.30	6.16	6.01	5.75
50	TC	43.83	39.27	32.61	50.92	47.89	42.70	57.04	55.16	51.22
	SHC	5.27	5.21	5.14	5.32	5.27	5.21	5.36	5.31	5.25
	kW	5.18	5.15	5.17	5.62	5.39	5.05	6.04	5.87	5.59
40	TC	45.75	41.13	34.50	53.08	50.00	44.64	59.24	57.40	53.44
	SHC	7.20	7.15	6.95	7.26	7.21	7.16	7.29	7.25	7.21
	kW	4.79	4.98	4.80	5.25	5.01	5.23	5.68	5.51	5.21

LEGEND

- Edb — Entering Dry-Bulb
- Ewb — Entering Wet-Bulb
- kW — Compressor Motor Power Input
- ldb — Leaving Dry-Bulb
- lwb — Leaving Wet-Bulb
- SHC — Sensible Heat Capacity (1000 Btuh) Gross
- TC — Total Capacity (1000 Btuh) Gross

NOTES:

1. Direct interpolation is permissible. Do not extrapolate.
2. The following formulas may be used:

$$t_{ldb} = t_{edb} - \frac{\text{sensible capacity (Btuh)}}{1.10 \times \text{cfm}}$$

t_{lwb} = Wet-bulb temperature corresponding to enthalpy of air leaving evaporator coil (h_{lwb})

$$h_{lwb} = h_{ewb} - \frac{\text{total capacity (Btuh)}}{4.5 \times \text{cfm}}$$

Where: h_{ewb} = Enthalpy of air entering evaporator coil

CAPACITY RATINGS (CONT)

COOLING CAPACITIES — 1-CIRCUIT/SINGLE CIRCUIT 2-STAGE COOLING, 8.5 TONS

558J-09N (RTPF)				AMBIENT TEMPERATURE (F)												
				85			95			105			115			
				EAT (db)			EAT (db)			EAT (db)			EAT (db)			
				75	80	85	75	80	85	75	80	85	75	80	85	
2550 Cfm	EAT (wb)	58	TC	85.4	85.4	95.6	81.6	81.6	93.2	78.1	78.1	89.2	74.1	74.1	84.6	
			SHC	72.2	83.9	95.6	70.1	81.6	93.2	67.0	78.1	89.2	63.5	74.1	84.6	
		62	TC	91.1	91.1	91.1	86.5	86.5	88.6	81.7	81.7	86.7	76.2	76.2	84.1	
			SHC	65.0	77.7	90.5	63.0	75.8	88.6	61.0	73.8	86.7	58.5	71.3	84.1	
		67	TC	101.8	101.8	101.8	96.9	96.9	96.9	91.2	91.2	91.2	85.1	85.1	85.1	
			SHC	53.4	66.1	78.8	51.5	64.2	77.0	49.2	62.1	74.9	46.9	59.8	72.7	
	72	TC	113.4	113.4	113.4	107.8	107.8	107.8	101.7	101.7	101.7	94.9	94.9	94.9		
		SHC	41.7	54.0	66.4	39.6	52.1	64.6	37.3	50.0	62.6	34.9	47.7	60.4		
	76	TC	—	123.5	123.5	—	117.3	117.3	—	110.5	110.5	—	103.2	103.2		
		SHC	—	43.8	57.9	—	42.0	56.1	—	40.0	51.1	—	37.7	49.6		
	2975 Cfm	EAT (wb)	58	TC	91.0	91.0	103.7	87.5	87.5	99.7	83.4	83.4	95.1	79.0	79.0	90.0
				SHC	78.3	91.0	103.7	75.2	87.5	99.7	71.8	83.4	95.1	67.9	79.0	90.0
62			TC	94.9	94.9	100.9	90.0	90.0	98.5	84.6	84.6	95.8	79.3	79.3	92.8	
			SHC	71.4	86.1	100.9	69.0	83.7	98.5	66.5	81.2	95.8	63.9	78.4	92.8	
67			TC	105.6	105.6	105.6	100.2	100.2	100.2	94.2	94.2	94.2	87.8	87.8	87.8	
			SHC	57.8	72.6	87.4	55.7	70.6	85.4	53.4	68.4	83.3	51.0	66.0	80.9	
72		TC	117.4	117.4	117.4	111.4	111.4	111.4	104.8	104.8	104.8	97.6	97.6	97.6		
		SHC	43.9	58.4	73.0	41.7	56.4	71.1	39.4	54.2	68.9	36.9	51.8	66.6		
76		TC	—	127.4	127.4	—	120.9	120.9	—	113.7	113.7	—	106.0	106.0		
		SHC	—	46.7	59.3	—	44.7	58.2	—	42.5	56.5	—	40.2	54.5		
3400 Cfm		EAT (wb)	58	TC	95.6	95.6	108.9	91.7	91.7	104.4	87.4	87.4	99.5	82.6	82.6	94.0
				SHC	82.4	95.6	108.9	79.1	91.7	104.4	75.3	87.4	99.5	71.1	82.6	94.0
	62		TC	97.4	97.4	108.3	92.6	92.6	106.1	88.2	88.2	101.6	82.9	82.9	97.3	
			SHC	75.9	92.1	108.3	73.8	90.0	106.1	70.5	86.1	101.6	67.1	82.2	97.3	
	67		TC	108.2	108.2	108.2	102.5	102.5	102.5	96.3	96.3	96.3	89.6	89.6	89.6	
			SHC	61.3	77.9	94.6	59.2	75.9	92.5	56.8	73.6	90.3	54.3	71.1	87.9	
	72	TC	120.1	120.1	120.1	113.8	113.8	113.8	106.9	106.9	106.9	99.4	99.4	99.4		
		SHC	45.6	62.0	78.4	43.4	59.9	76.4	41.0	57.6	74.2	38.5	55.2	71.8		
	76	TC	—	130.2	130.2	—	123.4	123.4	—	115.9	115.9	—	107.8	107.8		
		SHC	—	48.9	64.1	—	46.8	62.5	—	44.6	60.5	—	42.2	58.4		
	3825 Cfm	EAT (wb)	58	TC	100.1	100.1	113.8	95.9	95.9	109.0	91.2	91.2	103.7	86.0	86.0	97.8
				SHC	86.3	100.1	113.8	82.7	95.9	109.0	78.6	91.2	103.7	74.1	86.0	97.8
62			TC	100.6	100.6	116.8	96.8	96.8	111.5	91.3	91.3	107.9	86.1	86.1	101.8	
			SHC	81.2	99.0	116.8	77.6	94.5	111.5	74.6	91.3	107.9	70.3	86.1	101.8	
67			TC	110.5	110.5	110.5	104.6	104.6	104.6	98.1	98.1	98.1	91.2	91.2	95.3	
			SHC	65.1	83.7	102.3	62.9	81.5	100.1	60.5	79.2	97.9	57.9	76.6	95.3	
72		TC	122.5	122.5	122.5	115.9	115.9	115.9	108.7	108.7	108.7	101.0	101.0	101.0		
		SHC	47.4	65.8	84.2	45.2	63.7	82.2	42.7	61.3	79.9	40.2	58.8	77.5		
76		TC	—	132.6	132.6	—	125.6	125.6	—	117.8	117.8	—	109.5	109.5		
		SHC	—	51.1	68.6	—	49.0	66.8	—	46.7	64.8	—	44.2	62.5		
4250 Cfm		EAT (wb)	58	TC	103.4	103.4	117.5	99.0	99.0	112.5	94.0	94.0	106.8	88.5	88.5	100.7
				SHC	89.3	103.4	117.5	85.5	99.0	112.5	81.2	94.0	106.8	76.4	88.5	100.7
	62		TC	104.2	104.2	120.3	99.1	99.1	117.0	94.1	94.1	111.2	88.6	88.6	104.7	
			SHC	83.9	102.1	120.3	81.1	99.1	117.0	77.0	94.1	111.2	72.5	88.6	104.7	
	67		TC	112.2	112.2	112.2	106.2	106.2	106.7	99.5	99.5	104.2	92.3	92.3	101.5	
			SHC	68.3	88.5	108.8	66.0	86.4	106.7	63.5	83.9	104.2	60.8	81.2	101.5	
	72	TC	124.2	124.2	124.2	117.5	117.5	117.5	110.1	110.1	110.1	102.2	102.2	102.2		
		SHC	48.9	69.0	89.2	46.6	66.9	87.1	44.1	64.5	84.8	41.5	61.9	82.3		
	76	TC	—	134.4	134.4	—	127.2	127.2	—	119.2	119.2	—	110.7	110.7		
		SHC	—	53.0	72.4	—	50.9	70.5	—	48.5	68.4	—	46.0	66.1		

LEGEND

- Do not operate
- Cfm — Cubic feet per minute (supply air)
- EAT (db) — Entering Air Temperature (dry bulb)
- EAT (wb) — Entering Air Temperature (wet bulb)
- SHC — Sensible Heat Capacity (1000 Btuh) Gross
- TC — Total Capacity (1000 Btuh) Gross

NOTE: See Minimum-Maximum Airflow Ratings table on page 6. Do not operate outside these limits.

COOLING CAPACITIES — 2-CIRCUIT/2-STAGE COOLING, 10 TONS

558J-12D (RTPF and Novation®)			AMBIENT TEMPERATURE (F)													
			85			95			105			115				
			EAT (db)			EAT (db)			EAT (db)			EAT (db)				
			75	80	85	75	80	85	75	80	85	75	80	85		
3000 Cfm	EAT (wb)	58	TC	107.6	107.6	121.9	102.5	102.5	116.2	96.8	96.8	109.7	90.5	90.5	102.6	
			SHC	93.2	107.6	121.9	88.8	102.5	116.2	83.9	96.8	109.7	78.4	90.5	102.6	
		62	TC	113.6	113.6	116.5	107.1	107.1	113.4	99.7	99.7	109.8	91.8	91.8	104.9	
			SHC	84.6	100.6	116.5	81.5	97.4	113.4	78.0	93.9	109.8	73.7	89.3	104.9	
		67	TC	124.4	124.4	124.4	118.4	118.4	118.4	111.5	111.5	111.5	103.3	103.3	103.3	
			SHC	69.7	85.7	101.7	67.1	83.2	99.2	64.3	80.3	96.3	60.8	76.8	92.8	
	72	TC	135.8	135.8	135.8	129.7	129.7	129.7	122.8	122.8	122.8	115.0	115.0	115.0		
		SHC	54.3	70.4	86.6	52.0	68.1	84.2	49.3	65.4	81.6	46.4	62.5	78.6		
	76	TC	—	145.3	145.3	—	139.0	139.0	—	131.9	131.9	—	124.1	124.1		
		SHC	—	57.8	74.3	—	55.6	72.1	—	53.1	69.6	—	50.4	66.9		
	3500 Cfm	EAT (wb)	58	TC	114.2	114.2	129.4	108.9	108.9	123.4	102.9	102.9	116.6	96.3	96.3	109.1
				SHC	98.9	114.2	129.4	94.3	108.9	123.4	89.1	102.9	116.6	83.4	96.3	109.1
62			TC	117.2	117.2	127.9	111.0	111.0	124.7	104.0	104.0	119.5	96.5	96.5	113.7	
			SHC	91.1	109.5	127.9	88.1	106.4	124.7	83.9	101.7	119.5	79.3	96.5	113.7	
67			TC	127.8	127.8	127.8	121.7	121.7	121.7	114.5	114.5	114.5	106.6	106.6	106.6	
			SHC	73.8	92.3	110.8	71.3	89.8	108.3	68.4	87.0	105.5	65.2	83.8	102.3	
72		TC	139.4	139.4	139.4	133.0	133.0	133.0	125.8	125.8	125.8	117.9	117.9	117.9		
		SHC	56.0	74.6	93.1	53.7	72.2	90.8	51.0	69.6	88.2	48.1	66.7	85.4		
76		TC	—	148.8	148.8	—	142.2	142.2	—	134.9	134.9	—	126.8	126.8		
		SHC	—	60.2	79.5	—	58.0	77.1	—	55.4	74.5	—	52.7	71.6		
4000 Cfm		EAT (wb)	58	TC	119.0	119.0	134.9	114.0	114.0	129.2	108.0	108.0	122.4	101.1	101.1	114.6
				SHC	103.1	119.0	134.9	98.7	114.0	129.2	93.6	108.0	122.4	87.6	101.1	114.6
	62		TC	120.3	120.3	137.1	114.7	114.7	132.8	108.2	108.2	127.5	101.3	101.3	119.3	
			SHC	96.5	116.8	137.1	93.0	112.9	132.8	88.9	108.2	127.5	83.2	101.3	119.3	
	67		TC	130.5	130.5	130.5	124.1	124.1	124.1	116.8	116.8	116.8	108.7	108.7	111.1	
			SHC	77.7	98.6	119.5	75.2	96.2	117.2	72.3	93.3	114.4	69.1	90.1	111.1	
	72	TC	142.1	142.1	142.1	135.5	135.5	135.5	128.2	128.2	128.2	120.0	120.0	120.0		
		SHC	57.6	78.4	99.3	55.2	76.1	97.1	52.5	73.6	94.6	49.7	70.7	91.8		
	76	TC	—	151.4	151.4	—	144.7	144.7	—	137.1	137.1	—	—	—		
		SHC	—	62.3	83.8	—	60.0	81.4	—	57.5	78.8	—	—	—		
	4500 Cfm	EAT (wb)	58	TC	123.0	123.0	139.5	117.8	117.8	133.6	111.9	111.9	126.9	105.3	105.3	119.3
				SHC	106.6	123.0	139.5	102.1	117.8	133.6	97.0	111.9	126.9	91.2	105.3	119.3
62			TC	123.4	123.4	144.4	117.9	117.9	139.0	112.0	112.0	132.0	105.4	105.4	124.2	
			SHC	100.9	122.7	144.4	96.9	117.9	139.0	92.1	112.0	132.0	86.6	105.4	124.2	
67			TC	132.6	132.6	132.6	126.0	126.0	126.0	118.7	118.7	122.9	110.4	110.4	119.6	
			SHC	81.4	104.6	127.9	78.9	102.3	125.7	76.1	99.5	122.9	72.9	96.2	119.6	
72		TC	144.2	144.2	144.2	137.4	137.4	137.4	129.9	129.9	129.9	121.6	121.6	121.6		
		SHC	59.0	82.1	105.2	56.6	79.8	103.1	54.0	77.3	100.7	51.1	74.5	98.0		
76		TC	—	153.4	153.4	—	146.6	146.6	—	138.9	138.9	—	—	—		
		SHC	—	64.1	87.8	—	61.9	85.6	—	59.4	83.0	—	—	—		
5000 Cfm		EAT (wb)	58	TC	126.5	126.5	143.3	121.2	121.2	137.4	115.1	115.1	130.5	108.4	108.4	122.8
				SHC	109.6	126.5	143.3	105.0	121.2	137.4	99.8	115.1	130.5	93.9	108.4	122.8
	62		TC	126.5	126.5	149.1	121.3	121.3	142.9	115.2	115.2	135.8	108.5	108.5	127.8	
			SHC	104.0	126.5	149.1	99.7	121.3	142.9	94.7	115.2	135.8	89.1	108.5	127.8	
	67		TC	134.2	134.2	135.9	127.5	127.5	133.8	120.1	120.1	131.0	111.9	111.9	127.6	
			SHC	84.9	110.4	135.9	82.4	108.1	133.8	79.6	105.3	131.0	76.4	102.0	127.6	
	72	TC	145.8	145.8	145.8	139.0	139.0	139.0	131.3	131.3	131.3	122.9	122.9	122.9		
		SHC	60.3	85.6	110.8	57.9	83.4	108.9	55.3	81.0	106.6	52.5	78.2	104.0		
	76	TC	—	155.1	155.1	—	148.2	148.2	—	—	—	—	—	—		
		SHC	—	65.9	91.5	—	63.7	89.5	—	—	—	—	—	—		

LEGEND

- Do not operate
- Cfm — Cubic feet per minute (supply air)
- EAT (db) — Entering Air Temperature (dry bulb)
- EAT (wb) — Entering Air Temperature (wet bulb)
- SHC — Sensible Heat Capacity (1000 Btuh) Gross
- TC — Total Capacity (1000 Btuh) Gross

NOTE: See Minimum-Maximum Airflow Ratings table on page 6. Do not operate outside these limits.

CAPACITY RATINGS (CONT)

COOLING CAPACITIES — 2-CIRCUIT/2-STAGE COOLING, 10 TONS

558J 12 COOLING CAPACITIES, RTPF UNIT WITH PERFECT HUMIDITY SYSTEM IN SUBCOOLING MODE										
Temp (F) Air Entering Condenser (Edb)		Air Entering Evaporator - CFM								
		3000/0.04			4000/0.06			5000/0.07		
		Air Entering Evaporator - Ewb (F)								
		72	67	62	72	67	62	72	67	62
75	TC	142.85	129.44	116.93	152.09	138.44	125.76	157.99	144.23	132.06
	SHC	58.38	74.88	91.58	67.96	89.45	111.02	76.63	102.94	127.93
	kW	7.19	6.97	6.79	6.92	7.12	7.35	7.45	7.22	7.02
85	TC	132.33	119.68	107.86	140.92	128.03	116.10	146.41	133.41	121.98
	SHC	48.44	65.56	82.83	57.37	79.50	101.68	65.65	92.58	118.12
	kW	7.98	7.77	7.58	7.72	7.92	8.14	8.25	8.01	7.82
95	TC	121.41	109.52	98.43	129.35	117.22	106.04	134.43	122.20	111.50
	SHC	38.19	55.92	73.78	46.47	69.22	92.01	54.34	81.92	107.96
	kW	8.87	8.66	8.48	8.61	8.80	9.03	9.14	8.90	8.71
105	TC	110.04	98.92	88.56	117.27	105.94	95.53	121.88	110.46	100.54
	SHC	27.59	45.94	64.39	35.16	58.57	81.98	42.56	70.82	97.40
	kW	9.86	9.66	9.48	9.61	9.79	10.02	10.12	9.89	9.70
115	TC	98.09	87.74	78.13	104.62	94.08	84.45	108.76	98.13	89.01
	SHC	16.52	35.47	54.53	23.37	47.44	71.46	30.32	59.25	86.31
	kW	10.95	10.76	10.60	10.72	10.89	11.10	11.19	10.98	10.81

558J 12 COOLING CAPACITIES, RTPF UNIT WITH PERFECT HUMIDITY SYSTEM IN HOT GAS REHEAT MODE										
Temp (F) Air Entering Condenser (Edb)		Air Entering Evaporator - Ewb (F)								
		75 Dry Bulb			75 Dry Bulb			75 Dry Bulb		
		62.5 Wet Bulb			64 Wet Bulb			65.3 Wet Bulb		
		(50% Relative)			(56% Relative)			(60% Relative)		
		Air Entering Evaporator - CFM								
3000	4000	5000	3000	4000	5000	3000	4000	5000		
80	TC	44.78	39.41	31.89	53.22	49.44	43.38	60.56	58.12	53.32
	SHC	-0.44	-0.57	-0.69	-0.37	-0.51	-0.61	-0.33	-0.46	-0.56
	kW	6.96	6.77	6.52	7.26	7.13	6.91	7.54	7.45	7.27
75	TC	45.84	40.46	32.86	54.28	50.51	44.45	61.61	59.19	54.40
	SHC	0.53	0.40	0.29	0.60	0.47	0.37	0.64	0.52	0.42
	kW	6.77	6.56	6.29	7.11	6.95	6.72	7.41	7.31	7.12
70	TC	46.91	41.48	33.50	55.36	51.59	45.50	62.69	60.28	55.49
	SHC	1.51	1.38	1.27	1.57	1.45	1.35	1.61	1.50	1.40
	kW	6.54	6.32	6.02	6.90	6.74	6.49	7.23	7.13	6.92
60	TC	48.88	43.42	35.76	57.29	53.56	47.48	64.56	62.16	57.42
	SHC	3.44	3.34	3.24	3.51	3.40	3.31	3.55	3.45	3.37
	kW	6.45	6.16	6.70	6.93	6.72	6.39	7.38	7.24	6.96
50	TC	50.83	45.28	37.67	59.22	55.52	49.43	66.05	64.03	59.34
	SHC	5.38	5.29	5.20	5.45	5.36	5.28	5.48	5.40	5.33
	kW	6.46	6.01	6.34	6.98	6.71	6.29	8.15	7.38	7.02
40	TC	52.82	47.29	39.50	61.14	57.48	51.39	68.23	65.88	61.25
	SHC	7.32	7.24	7.20	7.38	7.31	7.24	7.43	7.36	7.29
	kW	6.29	6.09	6.12	7.05	6.72	6.29	7.78	7.55	7.10

LEGEND

- Edb — Entering Dry-Bulb
- Ewb — Entering Wet-Bulb
- kW — Compressor Motor Power Input
- ldb — Leaving Dry-Bulb
- lwb — Leaving Wet-Bulb
- SHC — Sensible Heat Capacity (1000 Btuh) Gross
- TC — Total Capacity (1000 Btuh) Gross

NOTES:

1. Direct interpolation is permissible. Do not extrapolate.
2. The following formulas may be used:

$$t_{ldb} = t_{edb} - \frac{\text{sensible capacity (Btuh)}}{1.10 \times \text{cfm}}$$

$$t_{lwb} = \text{Wet-bulb temperature corresponding to enthalpy of air leaving evaporator coil } (h_{lwb})$$

$$h_{lwb} = h_{ewb} - \frac{\text{total capacity (Btuh)}}{4.5 \times \text{cfm}}$$

Where: h_{ewb} = Enthalpy of air entering evaporator coil

COOLING CAPACITIES — 1-CIRCUIT/2-STAGE COOLING, 10 TONS

558J-12N (RTPF)			AMBIENT TEMPERATURE (F)													
			85			95			105			115				
			EAT (db)			EAT (db)			EAT (db)			EAT (db)				
			75	80	85	75	80	85	75	80	85	75	80	85		
3000 Cfm	EAT (wb)	58	TC	107.8	107.8	122.1	102.5	102.5	116.3	96.9	96.9	110.2	91.1	91.1	103.7	
			SHC	93.4	107.8	122.1	88.7	102.5	116.3	83.7	96.9	110.2	78.5	91.1	103.7	
		62	TC	114.4	114.4	114.4	107.9	107.9	110.8	100.8	100.8	106.6	93.8	93.8	102.7	
			SHC	83.7	99.0	114.4	80.0	95.4	110.8	76.0	91.3	106.6	72.2	87.5	102.7	
		67	TC	125.7	125.7	125.7	118.8	118.8	118.8	111.3	111.3	111.3	103.6	103.6	103.6	
			SHC	68.7	83.9	99.1	65.1	80.4	95.6	61.4	76.6	91.9	57.5	72.8	88.1	
	72	TC	138.0	138.0	138.0	130.8	130.8	130.8	122.8	122.8	122.8	114.4	114.4	114.4		
		SHC	53.8	68.6	83.4	50.3	65.2	80.1	46.6	61.5	76.5	42.7	57.7	72.8		
	76	TC	—	148.9	148.9	—	141.1	141.1	—	132.5	132.5	—	123.3	123.3		
		SHC	—	55.8	72.3	—	52.7	69.2	—	49.2	62.7	—	45.5	59.7		
	3500 Cfm	EAT (wb)	58	TC	114.0	114.0	129.1	108.4	108.4	122.9	102.4	102.4	116.3	96.2	96.2	109.4
				SHC	98.9	114.0	129.1	93.9	108.4	122.9	88.6	102.4	116.3	83.0	96.2	109.4
62			TC	118.1	118.1	125.6	111.3	111.3	121.6	104.1	104.1	117.5	96.9	96.9	112.5	
			SHC	90.4	108.0	125.6	86.5	104.1	121.6	82.5	100.0	117.5	78.0	95.3	112.5	
67			TC	129.4	129.4	129.4	122.2	122.2	122.2	114.4	114.4	114.4	106.4	106.4	106.4	
			SHC	73.1	90.7	108.2	69.5	87.1	104.6	65.7	83.3	100.9	61.8	79.4	97.0	
72		TC	141.9	141.9	141.9	134.3	134.3	134.3	126.0	126.0	126.0	117.2	117.2	117.2		
		SHC	55.8	73.1	90.3	52.3	69.6	86.8	48.5	65.8	83.1	44.6	61.9	79.3		
76		TC	—	152.2	152.2	—	144.5	144.5	—	135.4	135.4	—	126.0	126.0		
		SHC	—	58.6	74.0	—	55.3	71.4	—	51.6	68.1	—	47.8	64.6		
4000 Cfm		EAT (wb)	58	TC	119.2	119.2	134.9	113.3	113.3	128.4	107.0	107.0	121.5	100.4	100.4	114.1
				SHC	103.5	119.2	134.9	98.2	113.3	128.4	92.6	107.0	121.5	86.6	100.4	114.1
	62		TC	121.0	121.0	135.9	114.3	114.3	131.4	107.5	107.5	125.2	101.1	101.1	117.1	
			SHC	96.5	116.2	135.9	92.4	111.9	131.4	87.3	106.2	125.2	81.5	99.3	117.1	
	67		TC	132.3	132.3	132.3	124.9	124.9	124.9	117.0	117.0	117.0	108.5	108.5	108.5	
			SHC	77.3	97.2	117.0	73.6	93.5	113.3	69.8	89.7	109.5	65.8	85.6	105.5	
	72	TC	144.8	144.8	144.8	137.0	137.0	137.0	128.4	128.4	128.4	119.3	119.3	119.3		
		SHC	57.6	77.2	96.7	54.1	73.6	93.2	50.2	69.8	89.4	46.2	65.9	85.5		
	76	TC	—	155.4	155.4	—	146.8	146.8	—	137.7	137.7	—	127.9	127.9		
		SHC	—	61.0	79.4	—	57.5	76.2	—	53.8	72.7	—	49.8	69.0		
	4500 Cfm	EAT (wb)	58	TC	123.4	123.4	139.6	117.4	117.4	132.9	110.8	110.8	125.6	103.8	103.8	117.9
				SHC	107.2	123.4	139.6	101.8	117.4	132.9	95.9	110.8	125.6	89.7	103.8	117.9
62			TC	124.0	124.0	143.3	118.1	118.1	136.3	111.2	111.2	129.4	103.9	103.9	122.7	
			SHC	101.1	122.2	143.3	95.9	116.1	136.3	90.5	110.0	129.4	85.1	103.9	122.7	
67			TC	134.6	134.6	134.6	127.0	127.0	127.0	118.9	118.9	118.9	110.2	110.2	113.8	
			SHC	81.3	103.3	125.4	77.5	99.6	121.6	73.7	95.7	117.8	69.6	91.7	113.8	
72		TC	147.0	147.0	147.0	139.1	139.1	139.1	130.3	130.3	130.3	121.0	121.0	121.0		
		SHC	59.3	81.1	102.8	55.7	77.5	99.3	51.9	73.7	95.5	47.8	69.6	91.4		
76		TC	—	157.5	157.5	—	148.9	148.9	—	139.5	139.5	—	129.4	129.4		
		SHC	—	63.1	84.0	—	59.6	80.7	—	55.7	77.0	—	51.8	73.1		
5000 Cfm		EAT (wb)	58	TC	127.1	127.1	143.8	120.8	120.8	136.8	113.9	113.9	129.2	106.8	106.8	121.3
				SHC	110.5	127.1	143.8	104.8	120.8	136.8	98.7	113.9	129.2	92.4	106.8	121.3
	62		TC	127.7	127.7	148.1	121.2	121.2	141.5	114.0	114.0	134.3	106.9	106.9	126.2	
			SHC	104.4	126.3	148.1	99.3	120.4	141.5	93.7	114.0	134.3	87.6	106.9	126.2	
	67		TC	136.5	136.5	136.5	128.7	128.7	129.7	120.4	120.4	125.7	111.5	111.5	121.4	
			SHC	85.1	109.3	133.5	81.3	105.5	129.7	77.3	101.5	125.7	73.1	97.3	121.4	
	72	TC	149.0	149.0	149.0	140.9	140.9	140.9	131.8	131.8	131.8	122.4	122.4	122.4		
		SHC	60.9	84.9	108.8	57.3	81.3	105.2	53.4	77.3	101.3	49.4	73.3	97.2		
	76	TC	—	159.2	159.2	—	150.5	150.5	—	140.8	140.8	—	130.6	130.6		
		SHC	—	65.1	88.3	—	61.5	84.8	—	57.6	81.0	—	53.6	76.9		

LEGEND

- Do not operate
- Cfm** — Cubic feet per minute (supply air)
- EAT (db)** — Entering Air Temperature (dry bulb)
- EAT (wb)** — Entering Air Temperature (wet bulb)
- SHC** — Sensible Heat Capacity (1000 Btuh) Gross
- TC** — Total Capacity (1000 Btuh) Gross

NOTE: See Minimum-Maximum Airflow Ratings table on page 6. Do not operate outside these limits.

CAPACITY RATINGS (CONT)

COOLING CAPACITIES — 2-CIRCUIT/2-STAGE COOLING, 12.5 TONS

558J-14D (RTPF and Novation®)			AMBIENT TEMPERATURE (F)													
			85			95			105			115				
			EAT (db)			EAT (db)			EAT (db)			EAT (db)				
			75	80	85	75	80	85	75	80	85	75	80	85		
3600 Cfm	EAT (wb)	58	TC	127.6	127.6	142.9	121.7	121.7	137.6	115.0	115.0	130.0	108.3	108.3	122.6	
			SHC	110.3	126.6	142.9	105.8	121.7	137.6	99.9	115.0	130.0	94.1	108.3	122.6	
		62	TC	136.1	136.1	136.1	131.1	131.1	131.1	123.8	123.8	124.5	114.9	114.9	120.3	
			SHC	96.6	112.8	129.0	94.7	111.2	127.7	91.4	108.0	124.5	87.3	103.8	120.3	
		67	TC	146.2	146.2	146.2	142.0	142.0	142.0	136.2	136.2	136.2	128.8	128.8	128.8	
			SHC	78.5	94.4	110.3	76.9	93.1	109.2	74.7	91.0	107.3	71.7	88.1	104.6	
	72	TC	155.9	155.9	155.9	152.4	152.4	152.4	147.2	147.2	147.2	140.1	140.1	140.1		
		SHC	60.1	76.6	93.2	58.7	75.2	91.7	56.8	73.3	89.7	54.2	70.6	87.0		
	4200 Cfm	EAT (wb)	58	TC	132.2	132.2	149.5	128.2	128.2	144.9	121.9	121.9	137.8	115.0	115.0	130.1
				SHC	115.0	132.2	149.5	111.5	128.2	144.9	106.0	121.9	137.8	99.9	115.0	130.1
			62	TC	139.6	139.6	139.6	134.7	134.7	138.0	128.0	128.0	135.6	119.1	119.1	131.2
				SHC	102.5	120.8	139.0	100.8	119.4	138.0	98.1	116.8	135.6	93.9	112.6	131.2
67			TC	149.5	149.5	149.5	145.4	145.4	145.4	139.6	139.6	139.6	132.1	132.1	132.1	
			SHC	81.8	99.6	117.4	80.6	98.7	116.8	78.5	96.9	115.2	75.7	94.3	112.8	
72	TC	159.0	159.0	159.0	155.5	155.5	155.5	150.3	150.3	150.3	143.1	143.1	143.1			
	SHC	61.4	79.6	97.8	60.2	78.5	96.8	58.3	76.7	95.0	55.8	74.2	92.5			
4800 Cfm	EAT (wb)	58	TC	136.7	136.7	154.5	133.0	133.0	150.3	127.7	127.7	144.3	120.6	120.6	136.4	
			SHC	118.9	136.7	154.5	115.7	133.0	150.3	111.0	127.7	144.3	104.9	120.6	136.4	
		62	TC	142.2	142.2	147.8	137.4	137.4	147.1	131.0	131.0	144.7	122.8	122.8	140.3	
			SHC	107.7	127.8	147.8	106.2	126.7	147.1	103.6	124.2	144.7	99.3	119.8	140.3	
		67	TC	152.1	152.1	152.1	148.0	148.0	148.0	142.2	142.2	142.2	134.6	134.6	134.6	
			SHC	84.8	104.3	123.7	83.8	103.8	123.7	82.0	102.3	122.6	79.4	99.9	120.4	
72	TC	161.3	161.3	161.3	157.8	157.8	157.8	152.5	152.5	152.5	145.4	145.4	145.4			
	SHC	62.6	82.2	101.9	61.4	81.4	101.3	59.7	79.7	99.8	57.2	77.3	97.5			
5400 Cfm	EAT (wb)	58	TC	140.5	140.5	158.8	136.9	136.9	154.7	131.8	131.8	149.0	125.2	125.2	141.6	
			SHC	122.2	140.5	158.8	119	136.9	154.7	114.7	131.8	149.0	108.9	125.2	141.6	
		62	TC	144.3	144.3	155.7	139.6	139.6	155.0	133.5	133.5	152.4	125.8	125.8	147.8	
			SHC	112.2	133.9	155.7	110.9	132.9	155.0	108.1	130.2	152.4	103.9	125.8	147.8	
		67	TC	154.2	154.2	154.2	150.0	150.0	150.0	144.2	144.2	144.2	136.7	136.7	136.7	
			SHC	87.6	108.6	129.6	86.8	108.5	130.1	85.2	107.3	129.4	82.8	105.1	127.4	
72	TC	163.1	163.1	163.1	159.7	159.7	159.7	154.3	154.3	154.3	147.1	147.1	147.1			
	SHC	63.6	84.6	105.6	62.5	83.9	105.4	60.8	82.5	104.2	58.4	80.2	102.0			
6000 Cfm	EAT (wb)	58	TC	143.6	143.6	162.3	140.1	140.1	158.3	135.1	135.1	152.7	128.7	128.7	145.5	
			SHC	124.9	143.6	162.3	121.8	140.1	158.3	117.5	135.1	152.7	111.9	128.7	145.5	
		62	TC	146.1	146.1	162.4	141.7	141.7	161.5	135.6	135.6	159.2	128.8	128.8	151.2	
			SHC	116.1	139.3	162.4	114.7	138.1	161.5	112.1	135.6	159.2	106.4	128.8	151.2	
		67	TC	155.8	155.8	155.8	151.6	151.6	151.6	145.9	145.9	145.9	138.3	138.3	138.3	
			SHC	90.1	112.6	135.0	89.6	112.8	136.0	88.3	112.0	135.8	85.9	110.0	134.1	
72	TC	164.5	164.5	164.5	161.2	161.2	161.2	155.8	155.8	155.8	148.5	148.5	148.5			
	SHC	64.5	86.7	108.9	63.5	86.3	109.1	61.9	85.1	108.2	59.6	82.9	106.3			
76	TC	—	170.6	170.6	—	167.8	167.8	—	162.8	162.8	—	155.5	155.5			
	SHC	—	68.7	95.8	—	67.5	94.1	—	65.7	91.8	—	63.3	88.8			

LEGEND

- Do not operate
- Cfm — Cubic feet per minute (supply air)
- EAT (db) — Entering Air Temperature (dry bulb)
- EAT (wb) — Entering Air Temperature (wet bulb)
- SHC — Sensible Heat Capacity (1000 Btuh) Gross
- TC — Total Capacity (1000 Btuh) Gross

NOTE: See Minimum-Maximum Airflow - Natural Gas and Propane Ratings on page 6. Do not operate outside these limits.

COOLING CAPACITIES — 2-CIRCUIT/2-STAGE COOLING, 12.5 TONS

558J 14 COOLING CAPACITIES, RTPF UNIT WITH PERFECT HUMIDITY SYSTEM IN SUBCOOLING MODE										
Temp (F) Air Entering Condenser (Edb)		Air Entering Evaporator - CFM								
		3750/0.02			5000/0.06			6250/0.05		
		Air Entering Evaporator - Ewb (F)								
		72	67	62	72	67	62	72	67	62
75	TC	183.66	166.86	151.43	194.90	177.83	162.05	201.97	184.84	170.53
	SHC	79.39	100.52	121.91	91.70	119.42	147.05	102.94	137.00	166.71
	kW	9.82	9.63	9.46	9.58	9.76	9.96	10.04	9.84	9.67
85	TC	172.71	156.78	142.09	183.32	167.13	152.17	189.98	173.73	160.25
	SHC	69.03	90.92	112.95	80.69	109.17	137.51	91.49	126.33	156.65
	kW	10.82	10.63	10.45	10.57	10.76	10.96	11.04	10.84	10.67
95	TC	161.37	146.24	132.38	171.36	156.04	141.86	177.62	162.22	149.50
	SHC	58.44	81.04	103.77	69.42	98.67	127.71	79.83	115.45	146.15
	kW	11.92	11.73	11.56	11.68	11.86	12.05	12.14	11.93	11.77
105	TC	149.57	135.32	122.21	158.89	144.45	131.10	164.74	150.27	138.35
	SHC	47.57	70.92	94.32	57.85	87.91	117.61	67.79	104.26	135.30
	kW	13.12	12.94	12.77	12.89	13.06	13.24	13.32	13.13	12.97
115	TC	137.22	123.88	111.55	145.85	132.33	119.84	151.27	137.71	126.67
	SHC	36.31	60.47	84.57	45.87	76.77	107.19	55.34	92.66	123.98
	kW	14.41	14.25	14.10	14.20	14.35	14.53	14.59	14.42	14.28

558J 14 COOLING CAPACITIES, RTPF UNIT WITH PERFECT HUMIDITY SYSTEM IN HOT GAS REHEAT MODE										
Temp (F) Air Entering Condenser (Edb)		Air Entering Evaporator - Ewb (F)								
		75 Dry Bulb			75 Dry Bulb			75 Dry Bulb		
		62.5 Wet Bulb			64 Wet Bulb			65.3 Wet Bulb		
		(50% Relative)			(56% Relative)			(60% Relative)		
		Air Entering Evaporator - CFM								
		3750	5000	6250	3750	5000	6250	3750	5000	6250
80	TC	52.42	45.88	36.99	62.64	58.07	51.07	71.56	68.64	63.23
	SHC	-0.39	-0.54	-0.67	-0.31	-0.46	-0.58	-0.26	-0.40	-0.52
	kW	9.65	9.39	9.07	9.97	9.77	9.50	10.25	10.11	9.89
75	TC	53.45	46.63	36.10	63.77	59.11	51.87	72.76	69.80	64.31
	SHC	0.59	0.44	0.30	0.67	0.52	0.40	0.72	0.58	0.47
	kW	9.09	8.83	8.49	9.39	9.20	8.94	9.67	9.53	9.32
70	TC	54.33	46.91	37.58	64.77	60.01	52.30	73.80	70.80	65.24
	SHC	1.56	1.41	1.29	1.64	1.50	1.38	1.70	1.56	1.45
	kW	8.81	8.53	8.62	9.15	8.94	8.65	9.46	9.31	9.08
60	TC	55.47	49.48	40.48	66.62	62.07	54.88	75.68	72.76	67.28
	SHC	3.50	3.38	3.27	3.59	3.47	3.36	3.65	3.52	3.42
	kW	8.36	8.84	8.98	9.88	9.56	9.10	9.83	9.64	9.31
50	TC	58.33	51.72	42.81	68.72	63.93	55.84	77.74	74.77	69.24
	SHC	5.47	5.35	5.24	5.54	5.43	5.32	5.60	5.49	5.39
	kW	8.98	9.25	9.43	9.33	8.97	8.73	9.55	9.33	9.70
40	TC	60.33	53.69	46.89	70.67	65.93	49.83	79.46	76.62	71.24
	SHC	7.42	7.31	7.22	7.49	7.39	7.23	7.55	7.45	7.37
	kW	9.16	9.88	9.06	9.50	9.05	9.47	10.31	10.00	9.48

LEGEND
Edb — Entering Dry-Bulb
Ewb — Entering Wet-Bulb
kW — Compressor Motor Power Input
ldb — Leaving Dry-Bulb
lwb — Leaving Wet-Bulb
SHC — Sensible Heat Capacity (1000 Btuh) Gross
TC — Total Capacity (1000 Btuh) Gross

NOTES:
 1. Direct interpolation is permissible. Do not extrapolate.
 2. The following formulas may be used:

$$t_{ldb} = t_{edb} - \frac{\text{sensible capacity (Btuh)}}{1.10 \times \text{cfm}}$$

$$t_{lwb} = \text{Wet-bulb temperature corresponding to enthalpy of air leaving evaporator coil } (h_{lwb})$$

$$h_{lwb} = h_{ewb} - \frac{\text{total capacity (Btuh)}}{4.5 \times \text{cfm}}$$

Where: h_{ewb} = Enthalpy of air entering evaporator coil

CAPACITY RATINGS (CONT)

COOLING CAPACITIES — 2-CIRCUIT/2-STAGE COOLING, 15 TONS

558J-16D (RTPF)			AMBIENT TEMPERATURE (F)													
			85			95			105			115				
			EAT (db)			EAT (db)			EAT (db)			EAT (db)				
			75	80	85	75	80	85	75	80	85	75	80	85		
4500 Cfm	EAT (wb)	58	TC	156.6	156.6	175.2	149.4	149.4	169.1	141.6	141.6	160.2	133.3	133.3	150.9	
			SHC	134.7	154.9	175.2	129.8	149.4	169.1	123.0	141.6	160.2	115.7	133.3	150.9	
		62	TC	166.7	166.7	166.9	158.0	158.0	162.6	147.6	147.6	157.2	136.8	136.8	150.3	
			SHC	122.8	144.9	166.9	118.6	140.6	162.6	113.5	135.3	157.2	107.4	128.8	150.3	
		67	TC	184.1	184.1	184.1	175.6	175.6	175.6	165.6	165.6	165.6	154.5	154.5	154.5	
			SHC	101.6	123.7	145.7	98.1	120.2	142.3	94.0	116.1	138.2	89.4	111.5	133.6	
	72	TC	200.3	200.3	200.3	192.0	192.0	192.0	182.9	182.9	182.9	172.2	172.2	172.2		
		SHC	78.7	101.1	123.5	75.5	97.9	120.2	72.1	94.4	116.7	68.2	90.5	112.7		
	76	TC	—	211.4	211.4	—	203.1	203.1	—	193.8	193.8	—	183.9	183.9		
		SHC	—	82.2	107.0	—	79.3	103.8	—	76.0	100.2	—	72.6	96.5		
	5250 Cfm	EAT (wb)	58	TC	165.2	165.2	186.9	158.2	158.2	179.0	150.0	150.0	169.7	141.3	141.3	160.0
				SHC	143.5	165.2	186.9	137.4	158.2	179.0	130.2	150.0	169.7	122.7	141.3	160.0
62			TC	172.3	172.3	181.7	163.4	163.4	176.9	153.1	153.1	169.3	143.4	143.4	161.4	
			SHC	131.6	156.6	181.7	127.1	152.0	176.9	120.5	144.9	169.3	114.1	137.8	161.4	
67			TC	189.5	189.5	189.5	180.9	180.9	180.9	170.7	170.7	170.7	159.1	159.1	159.1	
			SHC	107.2	132.4	157.5	103.8	129.0	154.1	99.9	125.1	150.4	95.3	120.6	145.8	
72		TC	205.0	205.0	205.0	196.5	196.5	196.5	187.1	187.1	187.1	176.4	176.4	176.4		
		SHC	80.9	106.1	131.3	77.7	102.9	128.1	74.4	99.5	124.7	70.6	95.8	121.0		
76		TC	—	215.4	215.4	—	206.8	206.8	—	197.1	197.1	—	186.9	186.9		
		SHC	—	85.0	113.0	—	82.0	109.8	—	78.8	106.4	—	75.4	102.8		
6000 Cfm		EAT (wb)	58	TC	172.7	172.7	195.4	165.5	165.5	187.3	157.1	157.1	177.8	148.1	148.1	167.7
				SHC	150.0	172.7	195.4	143.8	165.5	187.3	136.4	157.1	177.8	128.6	148.1	167.7
	62		TC	176.6	176.6	195.7	168.1	168.1	187.6	158.9	158.9	180.2	148.9	148.9	172.1	
			SHC	139.6	167.7	195.7	133.2	160.4	187.6	127.1	153.7	180.2	120.7	146.4	172.1	
	67		TC	193.6	193.6	193.6	184.8	184.8	184.8	174.7	174.7	174.7	162.7	162.7	162.7	
			SHC	112.3	140.3	168.3	108.9	137.0	165.2	105.2	133.5	161.7	100.7	129.0	157.3	
	72	TC	208.4	208.4	208.4	199.6	199.6	199.6	190.2	190.2	190.2	179.5	179.5	179.5		
		SHC	82.7	110.5	138.3	79.6	107.3	135.1	76.2	104.0	131.8	72.6	100.6	128.5		
	76	TC	—	218.2	218.2	—	209.5	209.5	—	199.5	199.5	—	189.0	189.0		
		SHC	—	87.5	118.6	—	84.5	115.2	—	81.1	111.3	—	77.5	107.3		
	6750 Cfm	EAT (wb)	58	TC	178.8	178.8	202.4	171.6	171.6	194.2	163.1	163.1	184.6	153.8	153.8	174.1
				SHC	155.3	178.8	202.4	149.0	171.6	194.2	141.6	163.1	184.6	133.5	153.8	174.1
62			TC	181.0	181.0	203.6	173.0	173.0	197.5	163.8	163.8	190.1	153.9	153.9	181.1	
			SHC	144.1	173.9	203.6	139.1	168.3	197.5	133.3	161.7	190.1	126.7	153.9	181.1	
67			TC	196.8	196.8	196.8	187.9	187.9	187.9	177.7	177.7	177.7	165.5	165.5	167.9	
			SHC	117.0	147.7	178.4	113.7	144.5	175.4	110.1	141.1	172.2	105.6	136.8	167.9	
72		TC	211.0	211.0	211.0	202.2	202.2	202.2	192.5	192.5	192.5	181.8	181.8	181.8		
		SHC	84.3	114.5	144.7	81.2	111.5	141.7	77.9	108.1	138.4	74.4	104.9	135.4		
76		TC	—	220.2	220.2	—	211.5	211.5	—	201.3	201.3	—	190.6	190.6		
		SHC	—	89.5	122.8	—	86.4	119.4	—	83.0	115.4	—	79.4	111.5		
7500 Cfm		EAT (wb)	58	TC	183.9	183.9	208.2	176.6	176.6	199.8	168.2	168.2	190.3	158.6	158.6	179.5
				SHC	159.7	183.9	208.2	153.3	176.6	199.8	146.0	168.2	190.3	137.7	158.6	179.5
	62		TC	185.1	185.1	212.5	177.1	177.1	206.2	168.3	168.3	197.9	158.7	158.7	186.7	
			SHC	149.5	181.0	212.5	144.5	175.4	206.2	138.7	168.3	197.9	130.8	158.7	186.7	
	67		TC	199.3	199.3	199.3	190.3	190.3	190.3	180.0	180.0	181.7	167.8	167.8	177.8	
			SHC	121.3	154.6	187.9	118.1	151.6	185.1	114.4	148.1	181.7	110.1	144.0	177.8	
	72	TC	213.0	213.0	213.0	204.1	204.1	204.1	194.2	194.2	194.2	183.5	183.5	183.5		
		SHC	85.8	118.2	150.5	82.7	115.2	147.7	79.4	111.9	144.4	76.0	108.8	141.6		
	76	TC	—	221.9	221.9	—	213.0	213.0	—	202.7	202.7	—	191.8	191.8		
		SHC	—	91.2	126.5	—	88.2	123.1	—	84.7	119.2	—	81.2	115.3		

LEGEND

- Do not operate
- Cfm — Cubic feet per minute (supply air)
- EAT (db) — Entering Air Temperature (dry bulb)
- EAT (wb) — Entering Air Temperature (wet bulb)
- SHC — Sensible Heat Capacity (1000 Btuh) Gross
- TC — Total Capacity (1000 Btuh) Gross

NOTE: See Minimum-Maximum Airflow - Natural Gas and Propane Ratings on page 6. Do not operate outside these limits.

COOLING CAPACITIES — 2-CIRCUIT/2-STAGE COOLING, 15 TONS

558J 16 COOLING CAPACITIES, UNIT WITH PERFECT HUMIDITY SYSTEM IN SUBCOOLING MODE

Temp (F) Air Entering Condenser (Edb)		Air Entering Evaporator - CFM								
		4500/0.02			6000/0.06			7500/0.05		
		Air Entering Evaporator - Ewb (F)								
		72	67	62	72	67	62	72	67	62
75	TC	204.40	186.30	168.20	218.40	199.60	180.90	229.60	210.40	191.20
	SHC	98.90	118.10	137.20	114.80	133.70	152.60	127.60	146.20	164.90
	kW	11.57	11.22	10.77	11.78	11.45	11.00	12.06	11.64	11.35
85	TC	189.20	171.70	154.10	203.00	184.80	166.70	214.10	195.50	176.90
	SHC	79.50	103.40	127.30	96.50	120.20	144.00	110.20	133.70	157.30
	kW	12.59	12.24	11.81	12.81	12.50	12.03	13.05	12.66	12.47
95	TC	174.00	157.00	140.00	187.60	170.10	152.50	198.60	180.60	162.70
	SHC	60.00	88.70	117.50	78.20	106.80	135.30	92.90	121.30	149.70
	kW	13.68	13.35	12.86	13.91	13.57	13.05	14.15	13.75	13.47
105	TC	158.80	142.30	125.80	172.20	155.30	138.30	183.10	165.70	148.40
	SHC	40.50	74.10	107.70	59.90	93.30	126.70	75.50	108.80	142.00
	kW	14.67	14.41	13.88	14.90	14.55	14.10	15.15	14.73	14.53
115	TC	143.60	127.60	111.70	156.80	140.50	124.10	167.60	150.90	134.20
	SHC	21.00	59.40	97.80	41.60	79.90	118.10	58.10	96.30	134.20
	kW	15.77	15.38	14.88	15.88	15.65	15.10	16.12	15.84	15.54

558J 16 COOLING CAPACITIES, UNIT WITH PERFECT HUMIDITY SYSTEM IN HOT GAS REHEAT MODE

Temp (F) Air Entering Condenser (Edb)		Air Entering Evaporator - Ewb (F)								
		75 Dry Bulb 62.5 Wet Bulb (50% Relative)			75 Dry Bulb 64 Wet Bulb (56% Relative)			75 Dry Bulb 65.3 Wet Bulb (60% Relative)		
		Air Entering Evaporator - CFM								
		4500	6000	7500	4500	6000	7500	4500	6000	7500
		80	TC	83.75	84.85	88.95	86.65	91.90	92.90	87.90
SHC	37.50		42.80	55.10	30.90	40.40	44.50	24.80	29.30	34.10
kW	10.50		11.49	11.60	10.56	10.65	11.70	11.60	11.72	11.77
75	TC	85.00	86.00	90.50	88.05	93.60	94.65	89.20	93.45	97.85
	SHC	40.00	45.00	57.30	33.20	42.30	46.90	26.90	31.50	36.30
	kW	10.16	11.15	11.25	10.21	10.31	11.33	11.26	11.35	11.42
70	TC	86.15	87.35	91.50	89.20	94.30	96.10	90.40	94.10	98.95
	SHC	42.10	47.50	59.80	35.50	45.30	49.50	29.50	33.90	38.70
	kW	9.84	10.83	10.94	10.02	10.13	11.03	10.95	11.05	11.12
60	TC	88.90	90.10	94.25	92.00	97.10	98.20	93.20	96.90	101.75
	SHC	46.80	52.30	64.60	40.20	50.10	54.10	34.10	38.60	43.40
	kW	9.37	10.36	10.44	9.42	9.52	10.55	10.45	10.57	10.64
50	TC	91.70	92.80	97.00	94.80	99.90	101.00	96.10	99.70	104.20
	SHC	51.50	57.10	69.40	44.80	54.80	58.90	38.70	43.20	49.00
	kW	9.12	10.09	10.16	9.17	9.28	10.26	10.17	10.26	10.32
40	TC	94.45	95.60	99.80	97.45	102.55	103.70	98.65	102.35	107.00
	SHC	56.30	61.40	73.70	49.70	59.20	63.30	43.60	48.10	52.90
	kW	9.05	10.02	10.10	9.10	9.21	10.18	10.11	10.20	10.26

LEGEND

- Edb** — Entering Dry-Bulb
- Ewb** — Entering Wet-Bulb
- kW** — Compressor Motor Power Input
- ldb** — Leaving Dry-Bulb
- lwb** — Leaving Wet-Bulb
- SHC** — Sensible Heat Capacity (1000 Btuh) Gross
- TC** — Total Capacity (1000 Btuh) Gross

NOTES:

1. Direct interpolation is permissible. Do not extrapolate.
2. The following formulas may be used:

$$t_{ldb} = t_{edb} - \frac{\text{sensible capacity (Btuh)}}{1.10 \times \text{cfm}}$$

t_{lwb} = Wet-bulb temperature corresponding to enthalpy of air leaving evaporator coil (h_{lwb})

$$h_{lwb} = h_{ewb} - \frac{\text{total capacity (Btuh)}}{4.5 \times \text{cfm}}$$

Where: h_{ewb} = Enthalpy of air entering evaporator coil

PHYSICAL DATA

PHYSICAL DATA (COOLING) — 6 TONS

558J		558J-07A/G
REFRIGERATION SYSTEM		
	# Circuits / # Comp. / Type	1 / 1 / Scroll
	Puron® refrig. (R-410A)(lbs-oz)	14 - 2
	Perfect Humidity™ Puron® refrig. charge A/B (lbs-oz)	22 - 5
	Metering device	Accutrol*
	Perfect Humidity Metering Device	Accutrol + TXV
	High-press. Trip / Reset (psig)	630 / 505
	Low-press. Trip / Reset (psig)	54 / 117
	Compressor Capacity Staging (%)	100%
EVAP. COIL		
	Material	Cu / Al
	Coil Type (Tube Dia.)	3/8" RTPF
	Rows / FPI	4 / 15
	Total face area (ft²)	7.3
	Condensate drain conn. size	3/4"
PERFECT HUMIDITY™ COIL (558J-07G only)		
	Material	Cu / Al
	Coil Type (Tube dia.)	3/8" RTPF
	Rows / FPI	2 / 17
	Total face area (ft²)	5.2
EVAPORATOR FAN AND MOTOR		
Standard Static	Motor Qty. / Belt Qty. / Driver Type	1 / Belt
	Max BHP	2.4
	RPM range	1073-1457
	Motor frame size	56
	Fan Qty. / Type	1 / Centrifugal
Medium Static	Fan Diameter (in.)	10 x 10
	Motor Qty. / Belt Qty. / Driver Type	1 / Belt
	Max BHP	2.9†
	RPM range	1173-1518
	Motor frame size	56
High Static	Fan Qty. / Type	1 / Centrifugal
	Fan Diameter (in.)	10 x 10
	Motor Qty. / Belt Qty. / Driver Type	1 / Belt
	Max BHP	3.7
	RPM range	1474-1788
	Motor frame size	56
	Fan Qty. / Type	1 / Centrifugal
	Fan Diameter (in.)	10 x 10
CONDENSER COIL		
	Material (Tube/Fin)	Cu / Al
	Coil type	3/8" RTPF
	Rows / FPI	2 / 17
	Total Face Area (ft²)	21.3
COND. FAN / MOTOR		
	Qty / Motor Drive Type	1 / Direct
	Motor HP / RPM	1/4 / 1100
	Fan diameter (in.)	22
FILTERS		
	RA Filter # / Size (in.)	4 / 16 x 16 x 2
	OA inlet screen # / Size (in.)	1 / 20 x 24 x 1

* Accutrol is a trademark of Accutrol LLC.

† 575V motor utilizes 3.7 BHP.

NOTE: Perfect Humidity™ is not available with Novation® condenser coil models, only Round Tube / Plate Fin (RTPF)

PHYSICAL DATA (COOLING) — 7.5-8.5 TONS

558J	558J-08D/K	558J-08N*	558J-09D/K	558J-09N	
REFRIGERATION SYSTEM					
# Circuits / # Comp. / Type	2 / 2 / Scroll	1 / 1 / 2-Stage Scroll	2 / 2 / Scroll	1 / 1 / 2-Stage Scroll	
RTPF models R410A charge A/B (lbs-oz)	8-5 / 8-2	12-0	10-5 / 10-12	15-5	
Alternate (MCHX) R410A charge A/B (lbs-oz)	4-6 / 4-6	—	—	—	
Alternate (Perfect Humidity™) R-410A charge A/B (lbs-oz)	13-3 / 13-3	—	16-13 / 16-13	—	
Metering device	Accutrol	Accutrol + TXV	Accutrol	Accutrol + TXV	
Alternate Perfect Humidity Metering Device	Accutrol + TXV	—	Accutrol + TXV	—	
High-press. Trip / Reset (psig)	630 / 505	630 / 505	630 / 505	630 / 505	
Low-press. Trip / Reset (psig)	54 / 117	54 / 117	54 / 117	54 / 117	
Compressor Capacity Staging (%)	50 / 100%	66 / 100%	50% / 100%	66 / 100%	
EVAP. COIL					
Material	Cu / Al	Cu / Al	Cu / Al	Cu / Al	
Coil Type (Tube Dia.)	3/8" RTPF	3/8" RTPF	3/8" RTPF	3/8" RTPF	
Rows / FPI	3 / 15	3 / 15	3 / 15	3 / 15	
Total face area (ft²)	8.9	8.9	11.1	11.1	
Condensate drain conn. size	3/4"	3/4"	3/4"	3/4"	
PERFECT HUMIDITY COIL (558J---K units only)					
Material	Cu / Al	—	Cu / Al	—	
Coil Type (Tube Dia.)	3/8" RTPF	—	3/8" RTPF	—	
Rows / FPI	2 / 17	—	2 / 17	—	
Total face area (ft²)	3.9	—	5.2	—	
EVAPORATOR FAN AND MOTOR					
Standard Static	Motor Qty. / Driver Type	1 / Belt	1 / Belt	1 / Belt	1 / Belt
	Max BHP	1.7	1.7	1.7	1.7
	RPM range	489-747	489-747	518-733	518-733
	Motor frame size	56	56	56	56
	Fan Qty. / Type	1 / Centrifugal	1 / Centrifugal	1 / Centrifugal	1 / Centrifugal
Medium Static	Motor Qty. / Driver Type	1 / Belt	1 / Belt	1 / Belt	1 / Belt
	Max BHP	2.9 †	2.9 †	2.9	2.4
	RPM range	733-949	733-949	690-936	690-936
	Motor frame size	56	56	56	56
	Fan Qty. / Type	1 / Centrifugal	1 / Centrifugal	1 / Centrifugal	1 / Centrifugal
High Static	Motor Qty. / Driver Type	1 / Belt	N/A	1 / Belt	1 / Belt
	Max BHP	4.7		3.7	3.7
	RPM range	909-1102		838-1084	838-1084
	Motor frame size	14		56	56
	Fan Qty. / Type	1 / Centrifugal		1 / Centrifugal	1 / Centrifugal
Fan Diameter (in.)	15 x 15		15 x 15	15 x 15	
CONDENSER COIL					
Material (Tube/Fin)	Cu / Al	Cu / Al	Cu / Al	Cu / Al	
Coil type	3/8" RTPF	5/16" RTPF	3/8" RTPF	3/8" RTPF	
Rows / FPI	2 / 17	2 / 18	2 / 17	2 / 17	
Total Face Area (ft²)	20.5	20.5	25.1	21.4	
ALTERNATE (MCHX) CONDENSER COIL					
Material (Tube/Fin)	Al / Al	—	—	—	
Coil type	Novation®	—	—	—	
Rows / FPI	1 / 20	—	—	—	
Total Face Area (ft²)	20.5	—	—	—	
COND. FAN / MOTOR					
Qty / Motor Drive Type	2 / Direct	2 / Direct	2 / Direct	2 / Direct	
Motor HP / RPM	1/4 / 1100	1/4 / 1100	1/4 / 1100	1/4 / 1100	
Fan diameter (in.)	22	22	22	22	
FILTERS					
RA Filter # / Size (in.)	4 / 16 x 20 x 2	4 / 16 x 20 x 2	4 / 20 x 20 x 2	4 / 20 x 20 x 2	
OA inlet screen # / Size (in.)	1 / 20 x 24 x 1	1 / 20 x 24 x 1	1 / 20 x 24 x 1	1 / 20 x 24 x 1	

LEGEND.
 — Not applicable
 * 558J-08N is not available in 575 volt models.
 † 575V motor utilizes 3.7 BHP.

NOTE: Perfect Humidity is not available with Novation® condenser coil models, only Round Tube / Plate Fin (RTPF).

PHYSICAL DATA (CONT)

PHYSICAL DATA (COOLING) — 10-15 TONS

558J		558J-12D/K	558J-12N	558J-14D/K	558J-16D/K
REFRIGERATION SYSTEM					
# Circuits / # Comp. / Type		2 / 2 / Scroll	1 / 1 / 2-Stage Scroll	2 / 2 / Scroll	2 / 2 / Scroll
RTPF models R-410A charge A/B (lbs-oz)		10-5 / 10-3	21-0	11-0 / 11-6	15-14 / 16-12
Alternate (MCHX) R-410A charge A/B (lbs-oz)		6-0 / 6-0	—	7-6 / 8-0	—
Alternate (Perfect Humidity™) R-410A charge A/B (lbs-oz)		16-10 / 16-0	—	17-10 / 18-3	—
Metering device		Accutrol	Accutrol + TXV	Accutrol	Accutrol
Alternate Perfect Humidity Metering Device		Accutrol + TXV	—	Accutrol + TXV	—
High-press. Trip / Reset (psig)		630 / 505	630 / 505	630 / 505	630 / 505
Low-press. Trip / Reset (psig)		54 / 117	54 / 117	54 / 117	54 / 117
Compressor Capacity Staging (%)		50% / 100%	100%	50% / 100%	50% / 100%
EVAP. COIL					
Material		Cu / Al	Cu / Al	Cu / Al	Cu / Al
Coil Type (Tube Dia.)		3/8" RTPF	3/8" RTPF	3/8" RTPF	3/8" RTPF
Rows / FPI		4 / 15	4 / 15	4 / 15	3 / 15
Total face area (ft²)		11.1	11.1	11.1	17.5
Condensate drain conn. size		3/4"	3/4"	3/4"	3/4"
PERFECT HUMIDITY COIL (558J---K units only)					
Material		Cu / Al	—	Cu / Al	Cu / Al
Coil Type (Tube Dia.)		3/8" RTPF	—	3/8" RTPF	3/8" RTPF
Rows / FPI		2 / 17	—	2 / 17	2 / 17
Total face area (ft²)		8.4	—	8.4	13.8
EVAPORATOR FAN AND MOTOR					
Standard Static	Motor Qty. / Driver Type	1 / Belt	1 / Belt	1 / Belt	1 / Belt
	Max BHP	2.4	2.4	2.9*	2.9*
	RPM range	591-838	591-838	652-843	507-676
	Motor frame size	56	56	56	56
	Fan Qty. / Type	1 / Centrifugal	1 / Centrifugal	1 / Centrifugal	1 / Centrifugal
Medium Static	Fan Diameter (in.)	15 x 15	15 x 15	15 x 15	18 x 18
	Motor Qty. / Driver Type	1 / Belt	1 / Belt	1 / Belt	1 / Belt
	Max BHP	3.7	3.7	3.7	3.7
	RPM range	838-1084	838-1084	838-1084	627-851
	Motor frame size	56	56	56	56
High Static	Fan Qty. / Type	1 / Centrifugal	1 / Centrifugal	1 / Centrifugal	1 / Centrifugal
	Fan Diameter (in.)	15 x 15	15 x 15	15 x 15	18 x 18
	Motor Qty. / Driver Type	1 / Belt	1 / Belt	1 / Belt	1 / Belt
	Max BHP	4.7	4.7	4.7	6.5 / 6.9 / 7.0 / 8.3†
	RPM range	1022-1240	1022-1240	1022-1240	776-955
CONDENSER COIL	Motor frame size	14	14	14	S184T
	Fan Qty. / Type	1 / Centrifugal	1 / Centrifugal	1 / Centrifugal	1 / Centrifugal
CONDENSER COIL	Fan Diameter (in.)	15 x 15	15 x 15	15 x 15	18 x 18
	Material (Tube/Fin)	Cu / Al	Cu / Al	Cu / Al	Cu / Al
CONDENSER COIL	Coil Type	3/8" RTPF	3/8" RTPF	3/8" RTPF	3/8" RTPF
	Rows / FPI	2 / 17	2 / 17	3 / 17	2 / 17
CONDENSER COIL	Total Face Area (ft²)	25.1	25.1	25.1	2@23.1
	ALTERNATE (MCHX) CONDENSER COIL				
CONDENSER COIL	Material (Tube/Fin)	Al / Al	—	Al / Al	—
	Coil Type	Novation®	—	Novation	—
CONDENSER COIL	Rows / FPI	1 / 20	—	1 / 20	—
	Total Face Area (ft²)	25.1	—	25.1	—
COND. FAN / MOTOR					
COND. FAN / MOTOR	Qty / Motor Drive Type	2 / Direct	2 / Direct	1 / Direct	3 / Direct
	Motor HP / RPM	1/4 / 1100	1/4 / 1100	1/4 / 1175	1/4 / 1100
COND. FAN / MOTOR	Fan diameter (in.)	22	22	30	22
	FILTERS				
FILTERS	RA Filter # / Size (in.)	4 / 20 x 20 x 2	4 / 20 x 20 x 2	4 / 20 x 20 x 2	6 / 18 x 24 x 2 2 / 24 x 27 x 1 (vert.)
	OA inlet screen # / Size (in.)	1 / 20 x 24 x 1	1 / 20 x 24 x 1	1 / 20 x 24 x 1	1 / 30 x 39 x 1 (horiz.)

LEGEND

— Not applicable

* 575V motor utilizes 3.7 BHP.

† On size 16 units, Max BHP for the High Static motor varies with the motor's voltage; see the Voltage/BHP table to the right.

NOTE: Perfect Humidity is not available with Novation® condenser coil models, only Round Tube / Plate Fin (RTPF) up to size 16.

Voltage	BHP
208	6.5
230	6.9
460	7.0
575	8.3

OPTIONS AND ACCESSORIES

FACTORY-INSTALLED AND FIELD-INSTALLED ACCESSORIES

CATEGORY	ITEM	FACTORY-INSTALLED OPTION	FIELD-INSTALLED ACCESSORY
Cabinet	Thru-the-base electrical or gas-line connections	X	X
	Supply duct cover (16 size only)		X
	Hinged access panels	X	
Coil Options	Cu/Cu indoor and/or outdoor coils ¹	X	
	Pre-coated outdoor coils ¹	X	
	Premium, E-coated outdoor coils ¹	X	
Humidity Control	Perfect Humidity™ adaptive dehumidification system	X	
Condenser Protection	Condenser coil hail guard (louvered design)	X	X
Controls	Thermostats, temperature sensors, and subbases		X
	RTU Open - protocol controller	X	
	Smoke detector (supply and/or return air)	X	
	Horn/strobe annunciator ¹⁰		X
	Time Guard II compressor delay control circuit		X
	Phase monitor		X
	Condensate overflow switch		X
Economizers and Outdoor Air Dampers	EconoMi\$er® IV for electro-mechanical controls — Non FDD (Standard air leak damper models) ⁶	X	X
	EconoMi\$er2 for DDC controls, complies with FDD (Standard and Ultra Low Leak air damper models) ^{7, 9}	X	X
	Motorized 2 position outdoor air damper	X	X
	Manual outdoor air damper (25% and 50%)		X
	Barometric relief ²	X	X
	Power exhaust		X
	EconoMi\$er X for electro-mechanical controls, complies with FDD. (Standard and Ultra Low Leak air damper models) ⁶	X	X
Economizer Sensors and IAQ Devices	Single dry bulb temperature sensors ³	X	X
	Differential dry bulb temperature sensors ³		X
	Single enthalpy sensors ³	X	X
	Differential enthalpy sensors ³		X
	Wall or duct mounted CO ₂ sensor ³		X
	Unit mounted CO ₂ sensor ³	X	
Electric Heat	Electric resistance heaters		X
	Single point kit ¹¹		X
Indoor Motor and Drive	Multiple motor and drive packages	X	
	2-Speed Indoor Fan Motor system w/VFD controller (2-stage cool only with electro-mechanical and RTU Open controls. ⁸	X	
Low Ambient Control	Winter start kit ⁴		X
	Motormaster® head pressure controller ⁴		X
Power Options	Convenience outlet (powered)	X	
	Convenience outlet (un-powered): 15 amp factory-installed, 20 amp field-installed	X	X
	Non-fused disconnect ⁵	X	
	Disconnect switch bracket (16 size only)		X
Roof Curbs	Roof curb 14-in. (356 mm)		X
	Roof curb 24-in. (610 mm)		X

NOTES:

1. Novation® coated coils only available with E-coat.
2. Included with economizer.
3. Sensors used to optimize economizer performance.
4. See application data for assistance.
5. Available on units with MOCs of 80 amps or less.
6. FDD (Fault Detection and Diagnostic) capability per California Title 24 120.2i, ASHRAE 90.1-2016 and IECC-2015 Fault Detection and Diagnostic (FDD) requirements.
7. Models with RTU Open DDC controls comply with California Title 24 120.2i, ASHRAE 90.1-2016 and IECC-2015 Fault Detection and Diagnostic (FDD) requirements.
8. Required on all 558J**D/K models to meet DOE-2018.
9. Not available with 2-Speed Indoor Fan Motor system. 2-Speed Indoor Fan Motor system is required on all U.S. installations.
10. Requires a field-supplied 24V transformer for each application. See price pages for details.
11. See Electrical Data Table on pages 59-82 for single point kit requirements.

OPTIONS AND ACCESSORIES (CONT)

Economizer (dry-bulb or enthalpy)

Economizers save energy, money and improve comfort levels in the conditioned space. They bring in fresh, outside air for ventilation; and provide cool outside air to cool your building. This also is the preferred method of low ambient cooling. When integrated with CO₂ sensors, economizers can provide even more savings by coupling the ventilation air to only that amount required based on space occupancy.

Economizers are available, installed and tested by the factory, with either enthalpy or temperature dry-bulb inputs. There are also models for electromechanical, direct digital controllers and single speed fan or 2-speed indoor fan motors. Additional sensors are available as accessories to optimize the economizer.

Economizers include gravity controlled barometric relief that helps equalize building pressure and ambient air pressures. This can be a cost effective solution to prevent building pressurization. Economizers are available in Ultra Low Leak and standard low leak versions.

CO₂ sensor

Improves productivity and saves money by working with the economizer to intake only the correct amount of outside air for ventilation. As occupants fill your building, the CO₂ sensor detects their presence through increasing CO₂ levels, and opens the economizer appropriately.

When the occupants leave, the CO₂ levels decrease, and the sensor appropriately closes the economizer. This intelligent control of the ventilation air, called Demand Controlled Ventilation (DCV) reduces the overall load on the rooftop, saving money.

Smoke detectors

Smoke detectors make your rooftop unit application safer and your job easier. Bryant smoke detectors immediately shut down the rooftop unit when smoke is detected. They are available, installed by the factory, for supply air, return air, or both.

Louvered hail guards

Sleek, louvered panels protect the condenser coil from hail damage, foreign objects, and incidental contact.

Convenience outlet (powered or un-powered)

Reduce service and/or installation costs by including a convenience outlet in your specification. Bryant will install this service feature at our factory. Provides a convenient, 15 amp, 115v GFCI receptacle with “Wet in Use” cover. The “powered” option allows the installer to power the outlet from the line side of the disconnect side as required by code. The “un-powered” option is to be powered from a separate (non-unit) 115/120v power source. The unpowered convenience outlet is available as a 15 amp factory-installed option or a 20 amp field-installed accessory.

The field installed 20 amp unpowered convenience outlet kit provides a flexible installation method which allows code compliance for height requirements of the GFCI outlet from the finished roof surface as well as the capability to relocate the outlet to a more convenient location, if necessary.

This system expands the envelope of operation of Bryant’s Legacy™ Line rooftop products to provide unprecedented flexibility to meet year round comfort conditions.

Non-fused disconnect

This OSHA-compliant, factory-installed, safety switch allows a service technician to locally secure power to the rooftop.

Disconnect switch bracket

Provides a pre-engineered and sized mounting bracket for applications requiring a unit mounted fused and non-fused disconnect of greater than 100 amps. Bracket assures that no damage will occur to coils when mounting with screws and other fasteners (16 size only).

Power exhaust with barometric relief

Superior internal building pressure control. This field-installed accessory or factory-installed option may eliminate the need for costly, external pressure control fans.

RTU Open protocol controller

Connect the rooftop to an existing Building Automation System (BAS) without needing complicated translators or adapter modules using the RTU Open controller. This new controller speaks the 4 most common building automation system languages (BACnet¹, Modbus², LonWorks³, and N2). Use this controller when you have an existing BAS.

Time guard II control circuit

This accessory protects your compressor by preventing short-cycling in the event of some other failure, prevents the compressor from restarting for 30 seconds after stopping. Not required with RTU Open controller or authorized commercial thermostats.

Filter or fan status switches

Use these differential pressure switches to detect a filter clog or indoor fan motor failure. When used in conjunction with a compatible unit controller/thermostat, the switches will activate an alarm to warn the appropriate personnel.

Motorized two-position damper

The new Bryant two-position, motorized outdoor air damper admits up to 100% outside air. Using reliable, gear-driven technology, the two-position damper opens to allow ventilation air and closes when the rooftop stops, stopping unwanted infiltration.

Manual OA damper

Manual outdoor air dampers are an economical way to bring in ventilation air. The dampers are available in 25% and 50% versions.

Optional Perfect Humidity™ dehumidification system

Bryant’s Perfect Humidity dehumidification system is an all-inclusive factory-installed option that can be ordered with any Legacy™ Line 558J*07-16 rooftop unit equipped with Round Tube-Plate Fin (RTPF) coils. Not available on single circuit, 2-stage cooling 558J***N models from 7.5 to 10 ton.

-
1. BACnet is a registered trademark of ASHRAE (American Society of Heating, Refrigerating and Air-Conditioning Engineers).
 2. Modbus is a registered trademark of Schneider Electric.
 3. LonWorks is a registered trademark of Echelon Corporation.

The Perfect Humidity™ adaptive dehumidification system has a unique dual operational mode setting. The Perfect Humidity system includes two new modes of operation.

The Legacy Line 558J rooftop coupled with the Perfect Humidity system is capable of operating in normal design cooling mode, subcooling mode, and hot gas reheat mode. Normal design cooling mode is when the unit will operate under its normal sequence of operation by cycling compressors to maintain comfort conditions.

Subcooling mode will operate to satisfy part load type conditions when the space requires combined sensible and a higher proportion of latent load control. Hot Gas Reheat mode will operate when outdoor temperatures diminish and the need for latent capacity is required for sole humidity control. Hot Gas Reheat mode will provide neutral air for maximum dehumidification operation.

2-speed indoor fan motor system

Bryant's 2-speed indoor fan motor system saves energy and installation time by automatically adjusting the indoor fan motor speed in sequence with the units cooling operation. Per ASHRAE 90.1-2016 standard during the first stage of cooling operation the fan speed will adjust the fan motor to provide 66% of the total cfm established for the unit. When a call for the second stage of cooling is required, the fan system will allow the total cfm for the unit established (100%). During the heating mode the fan speed will allow total design cfm (100%) operation and during the ventilation mode the fan speed will allow operation to 66% of total cfm.

Compared to single speed indoor fan motor systems, Bryant's 2-speed indoor fan motor system can save substantial energy, 25%+ versus single speed indoor fan motor systems.

IMPOTRANT: Data based on .10 (\$/kWh) in an office application utilizing Bryant's HAP 4.6 simulation software program.
--

Bryant's 2-speed indoor fan motor system has soft start capabilities to slowly ramp up the fan speeds, thus eliminating any high inrush air volume during initial start-up. It also has internal over current protection for the fan motor and a field-installed display kit that allows adjustment and in depth diagnostics if required.

This 2-speed indoor fan motor will allow both space sensor and conventional thermostats controls to be used to provide accurate control in any application.

The 2-speed indoor fan motor system is factory preprogrammed and tested and requires no field adjustment to set up. The unit fan performance static pressure and cfm can be easily adjusted using the traditional means of belt drive pulley adjustments.

Motormaster® head pressure controller

The Motormaster motor controller is a low ambient, head pressure controller kit that is designed to maintain the unit's condenser head pressure during periods of low ambient cooling operation. This device should be used as an alternative to economizer free cooling when economizer usage is either not appropriate or desired. The Motormaster controller will either cycle the outdoor-fan motors or operate them at reduced speed to maintain the unit operation, depending on the model.

Hinged access panels

Allows access to unit's major components with specifically designed hinged access panels. Panels are: filter, control box, and fan motor.

Winter start kit

The winter start kit by Bryant extends the low ambient limit of your rooftop to 25°F (-4°C). The kit bypasses the low pressure switch, preventing nuisance tripping of the low pressure switch. Other low ambient precautions may still be prudent.

Alternate motors and drives

Some applications need larger horsepower motors, some need more airflow, and some need both. Regardless of the case, your Bryant expert has a factory-installed combination to meet your application. A wide selection of motors and pulleys (drives) are available, factory-installed, to handle nearly any application.

Thru-the-base connections

Thru-the-base connections, available as either an accessory or as a factory option, are necessary to ensure proper connection and seal when routing wire and piping through the rooftop's basepan and curb. These couplings eliminate roof penetration and should be considered for gas lines, main power lines, as well as control power.

Electric heaters / Single point kit

Bryant offers a full-line of field-installed accessory heaters and single point kits when required. The heaters are very easy to use, install, and are all pre-engineered and certified.

Condensate Overflow Switch

Includes electronic controller and sensor. Compressor(s) turn off if the drain trap becomes plugged but the indoor fan motor remains running.

Supply duct cover

The supply duct cover is required when field converting the factory standard vertical duct supply to the horizontal duct supply configuration. One required per unit (16 size only).

DIMENSIONS

OPTIONS AND ACCESSORIES — WEIGHT ADDERS

BASE UNIT WITH OPTIONS AND ACCESSORIES (WEIGHT ADDERS)	MAX WEIGHT ADDER											
	558J*07		558J*08		558J*09		558J*12		558J*14		558J*16	
	lb	kg	lb	kg	lb	kg	lb	kg	lb	kg	lb	kg
Perfect Humidity™ System ^{1, 2}	55	25	80	36	80	36	80	36	85	39	90	41
Power Exhaust, Vertical	50	23	75	34	75	34	75	34	75	34	85	39
Power Exhaust, Horizontal	30	14	30	14	30	14	30	14	30	14	75	34
EconoMi\$er® (IV, X, or 2)	50	23	75	34	75	34	75	34	75	34	115	52
Cu/Cu Condenser Coil ³	28	13	28	13	30	14	34	15	34	15	34	15
Cu/Cu Condenser and Evaporator Coils ³	53	24	58	26	64	29	64	29	64	29	64	29
Roof Curb 14-in. (356 mm)	115	52	143	65	143	65	143	65	132	65	180	82
Roof Curb 24-in. (610 mm)	197	90	245	111	245	111	245	111	245	111	255	116
Louvered Hail Guard	16	7	34	15	34	15	34	15	34	15	45	20
CO ₂ Sensor	5	2	5	2	5	2	5	2	5	2	5	2
Return Smoke Detector	5	2	5	2	5	2	5	2	5	2	5	2
Supply Smoke Detector	5	2	5	2	5	2	5	2	5	2	5	2
Fan/Filter Status Switch	2	1	2	1	2	1	2	1	2	1	2	1
Non-Fused Disconnect	15	7	15	7	15	7	15	7	15	7	15	7
Powered Convenience Outlet	35	16	35	16	35	16	35	16	35	16	35	16
Non-Powered Convenience Outlet	5	2	5	2	5	2	5	2	5	2	5	2
Enthalpy Sensor	2	1	2	1	2	1	2	1	2	1	2	1
Differential Enthalpy Sensor	3	1	3	1	3	1	3	1	3	1	3	1
Two Position Motorized Damper	39	18	58	26	58	26	58	26	58	26	65	29
Manual Damper	12	5	18	8	18	8	18	8	18	8	25	11
Motormaster® Controller	35	16	35	16	35	16	35	16	35	16	35	16
Medium Static Motor/Drive	5	2	6	3	6	3	6	3	10	5	10	5
High Static Motor/Drive	11	5	12	5	16	7	16	7	20	9	20	9
2-Speed Indoor Fan Motor System	20	9	20	9	20	9	20	9	20	9	20	9

¹ For Perfect Humidity System add Motormaster Controller.

² Perfect Humidity system is not available for 558J*08/09/12N units

³ Where available

UNIT DIMENSIONAL DRAWING - 07 SIZE UNIT

- NOTES:**
1. DIMENSIONS ARE IN INCHES. DIMENSIONS IN PARENTHESES ARE IN MILLIMETERS.
 2. CENTER OF GRAVITY
 3. DIRECTION OF AIR FLOW

UNIT	J	K
07	41-3/8 (1023)	14-7/8 (377)

CONNECTION SIZES	
A	1-3/8" [35] DIA. FIELD POWER SUPPLY HOLE
B	2" [51] DIA. POWER SUPPLY MOCK-OUT
C	1-3/4" [44] DIA. GAUGE ACCESS PLUG
D	7/8" [22] DIA. FIELD CONTROL WIRING HOLE
E	3/4"-14 NPT CONDENSATE DRAIN
G	2-1/2" [64] DIA. POWER SUPPLY MOCK-OUT

THRU-THE-BASE CHART THESE HOLES REQUIRED FOR USE CDBMPR001A01		
W	1/2"	WIRE SIZE (MAX.)
X	1/2"	ACC.
Y	3/4" [001]	POWER

FOR "THRU-THE-BASEPAN" FACTORY OPTION,
DIMENSIONS X & Y ARE
FITTINGS PROVIDED

* SELECT EITHER 3/4" OR 1/2"
FOR POWER, DEPENDING ON WIRE SIZE

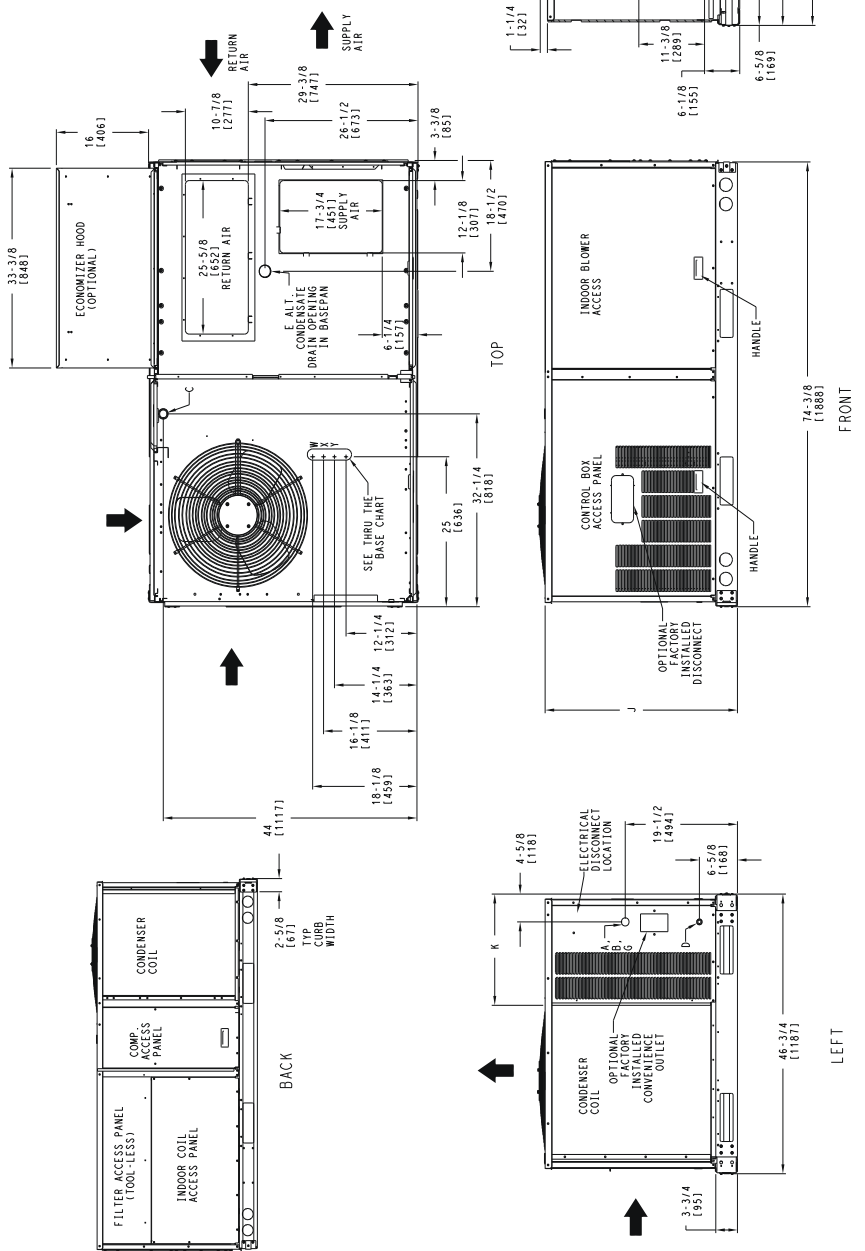

DIMENSIONS (CONT)

UNIT DIMENSIONAL DRAWING - 07 SIZE UNIT (cont)

UNIT	STD. UNIT WEIGHT*		CORNER WEIGHT (A)		CORNER WEIGHT (B)		CORNER WEIGHT (C)		CORNER WEIGHT (D)		C.G.		HEIGHT			
	LBS.	KG.	LBS.	KG.	LBS.	KG.	LBS.	KG.	LBS.	KG.	X	Y	Z	Z		
07	607	275	150	68	160	73	153	69	144	65	38	1965	22	1527	20 3/4	1527

* STANDARD UNIT WEIGHT IS WITHOUT ELECTRIC HEAT AND WITHOUT PACKAGING.

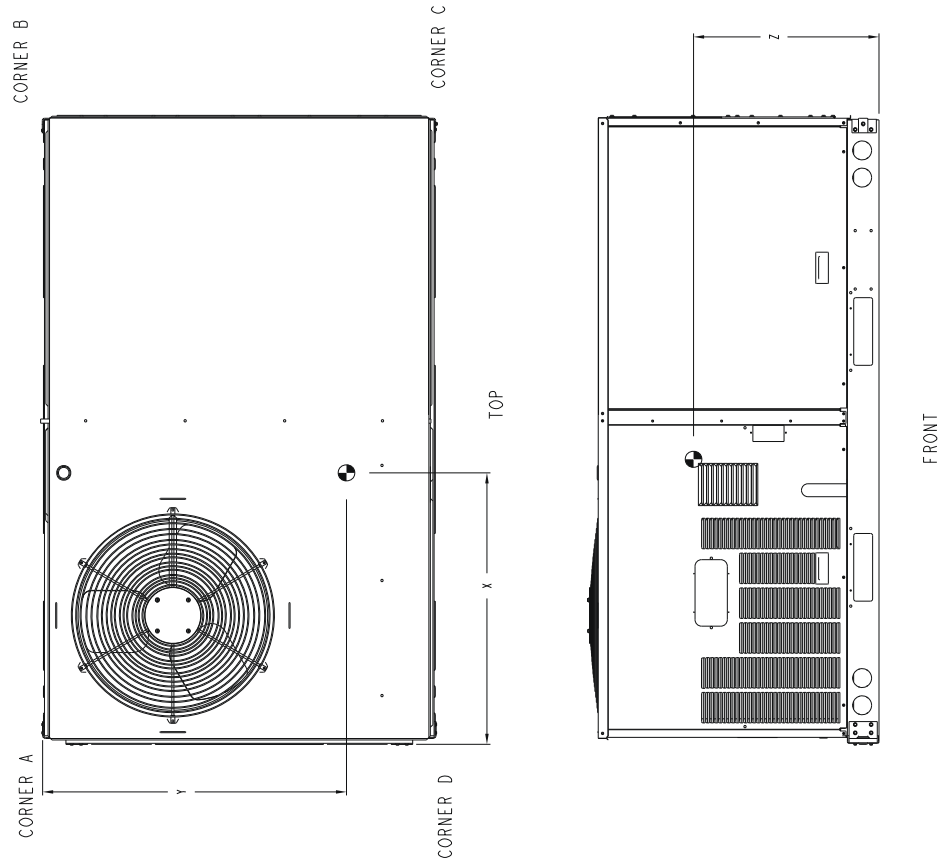

SERVICE CLEARANCE DIMENSIONAL DRAWING — 07 SIZE UNIT

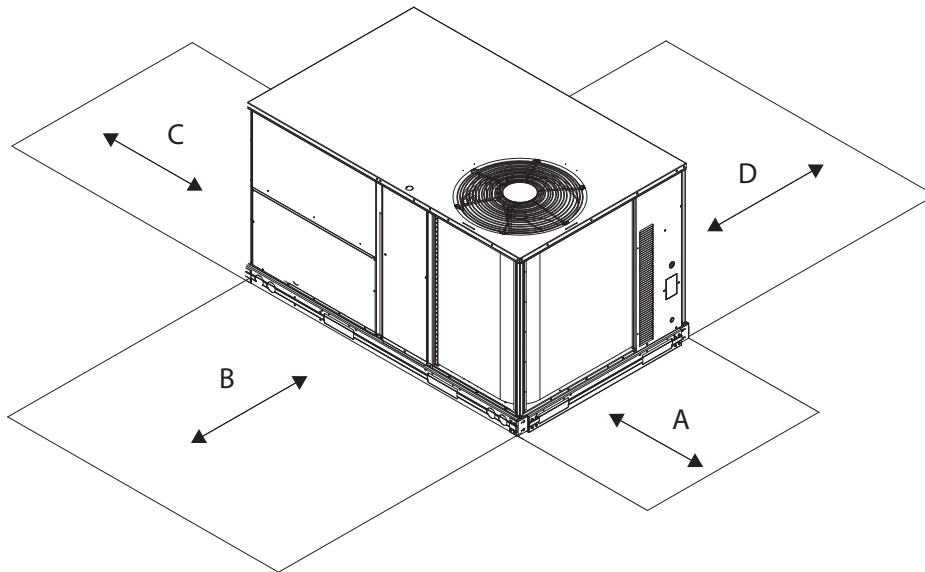

LOC	DIMENSION	CONDITION
A	48-in. (1219 mm) 18-in. (457 mm) 18-in. (457 mm) 12-in. (305 mm)	<ul style="list-style-type: none"> • Unit disconnect is mounted on panel • No disconnect, convenience outlet option • Recommended service clearance • Minimum clearance
B	42-in. (1067 mm) 36-in. (914 mm) Special	<ul style="list-style-type: none"> • Surface behind servicer is grounded (e.g., metal, masonry wall) • Surface behind servicer is electrically non-conductive (e.g., wood, fiberglass) • Check for sources of flue products within 10-ft of unit fresh air intake hood
C	36-in. (914 mm) 18-in. (457 mm)	<ul style="list-style-type: none"> • Side condensate drain is used • Minimum clearance
D	42-in. (1067 mm) 36-in. (914 mm)	<ul style="list-style-type: none"> • Surface behind servicer is grounded (e.g., metal, masonry wall, another unit) • Surface behind servicer is electrically non-conductive (e.g., wood, fiberglass)

NOTE: Unit not designed to have overhead obstruction.
Contact Application Engineering for guidance on any application planning overhead obstruction or vertical clearances.

DIMENSIONS (CONT)

ROOF CURB DETAILS — 07 SIZE UNIT

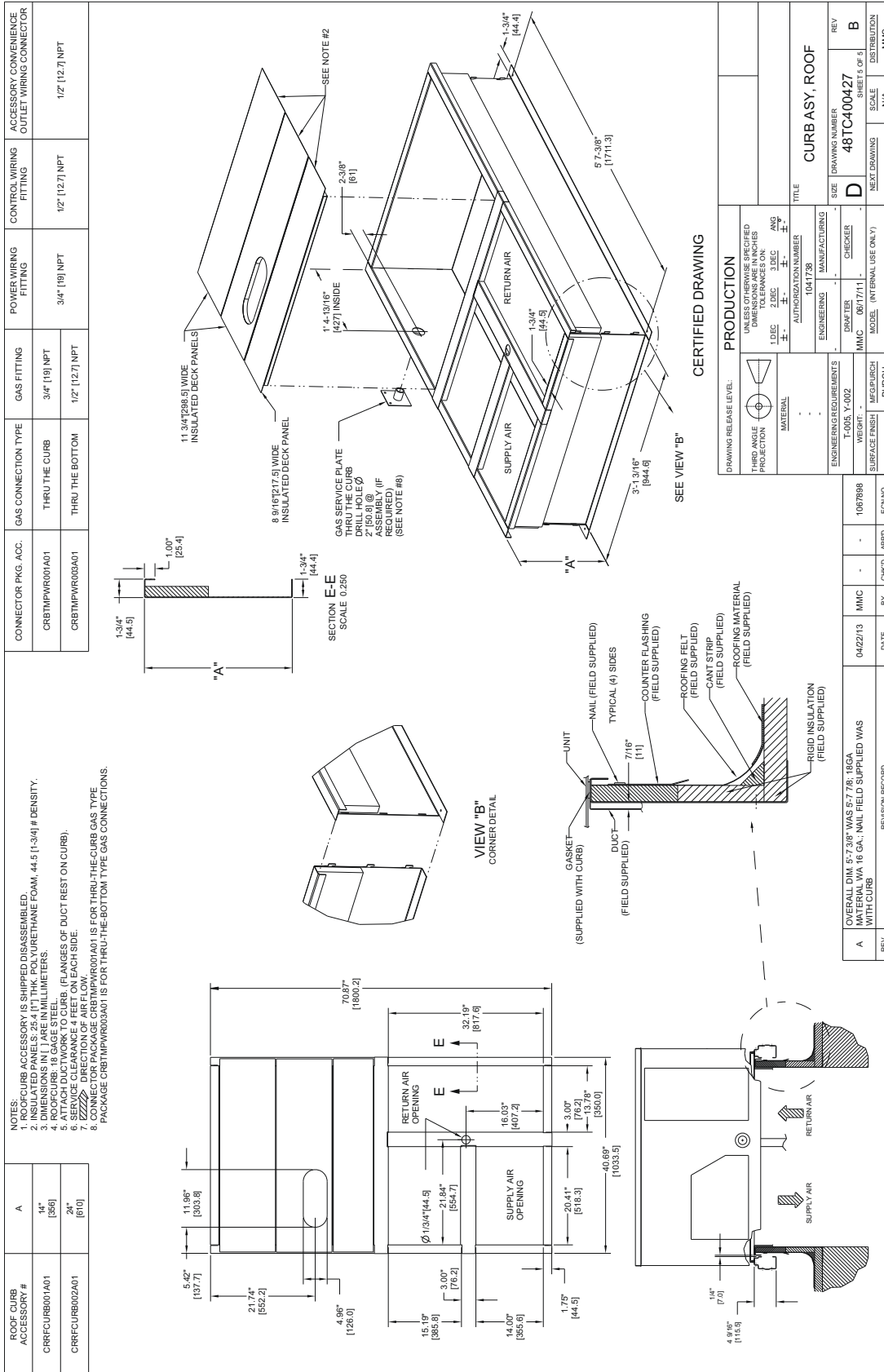

DIMENSIONS (CONT)

UNIT DIMENSIONAL DRAWING — 08 - 12 SIZE UNIT (cont)

THIS DOCUMENT IS THE PROPERTY OF CARBER CORPORATION AND IS DELIVERED UNDER THE EXPRESS CONDITION THAT THE USER SHALL NOT REPRODUCE OR TRANSMIT IN ANY MANNER WITHOUT THE WRITTEN CONSENT OF CARBER CORPORATION.

*** STANDARD UNIT WEIGHT IS WITHOUT ELECTRIC HEAT AND WITHOUT PACKAGING. FOR OTHER OPTIONS AND ACCESSORIES, REFER TO THE PRODUCT DATA CATALOG.

UNIT	STD. UNIT WEIGHT ***		CORNER WEIGHT (A)		CORNER WEIGHT (B)		CORNER WEIGHT (C)		CORNER WEIGHT (D)		C. G.			
	LBS.	KG.	LBS.	KG.	LBS.	KG.	LBS.	KG.	LBS.	KG.	X	Y	Z	
558J-08N	705	320	172	78	142	64.5	177	80.4	214	97.2	39 7/8 [1003]	33 [838]	21 1/4 [540]	
558J-09N	845	383.6	206	93.5	167	76	212	96.2	261	118.5	39 1/2 [1003]	33 1/4 [845]	24 [610]	
558J-12N	855	388	210	95.3	180	81.7	215	97.6	250	113.5	40 3/4 [1035]	32 3/8 [822]	25 1/4 [641]	
558J-08D	760	345	158	71.7	155	70.4	222	100.8	225	102.2	43 3/4 [1111.3]	35 [889]	20 [508]	
558J-09D	865	388.2	223	101.2	171	77.6	200	90.8	261	118.5	38 3/8 [975]	32 1/8 [816]	19 1/8 [486]	
558J-12D	865	392.7	225	102.2	173	78.5	203	92.2	264	120	38 3/8 [975]	32 1/8 [816]	19 1/8 [486]	
558J-08D	MCHX	730	331.4	153	69.5	138	64	208	94.4	231	104.9	41 3/4 [1060.5]	35 3/4 [908]	21 1/8 [536.6]
558J-12D	MCHX	820	372.3	179	81.3	161	73.1	228	103.5	253	114.9	41 3/4 [1060.5]	34 7/8 [885.8]	23 3/4 [603.3]

RTPF - ROUND TUBE, PLATE FIN (COPPER/ALUM)
MCHX - NOVATION (ALUM/ALUM)

SHEET 2 OF 2

DATE 10-01-10

SUPERCESSES 01-16-09

FRONT

558J 08-12 SINGLE ZONE ELECTRICAL COOLING WITH ELECTRIC HEAT

REV G

48TMS00990

48TMS00990

48TMS00990

SERVICE CLEARANCE DIMENSIONAL DRAWING — 08-12 SIZE UNITS

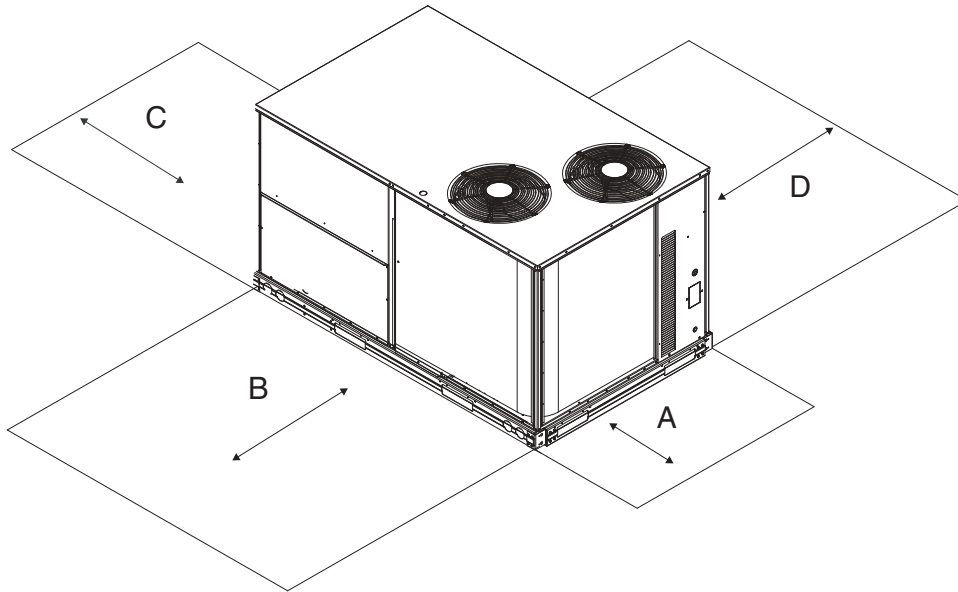

LOC	DIMENSION	CONDITION
A	48-in. (1219 mm) 36-in. (914 mm) 18-in. (457 mm) 18-in. (457 mm) 12-in. (305 mm)	<ul style="list-style-type: none"> • Unit disconnect is mounted on panel • If dimension B is 12-in. (305 mm) • No disconnect, convenience outlet option • Recommended service clearance (electric screwdriver) • Minimum clearance (use manual ratchet screwdriver)
B	36-in. (914 mm) 12-in. (305 mm) Special	<ul style="list-style-type: none"> • Unit has economizer • If dimension A is 36-in. (914 mm) • Check for sources of flue products within 10-ft of unit fresh air intake hood
C	36-in. (914 mm) 18-in. (457 mm)	<ul style="list-style-type: none"> • Side condensate drain is used • Minimum clearance
D	42-in. (1067 mm) 36-in. (914 mm)	<ul style="list-style-type: none"> • Surface behind servicer is grounded (e.g., metal, masonry wall, another unit) • Surface behind servicer is electrically non-conductive (e.g., wood, fiberglass)

NOTE: Unit not designed to have overhead obstruction.
Contact Application Engineering for guidance on any application planning overhead obstruction or vertical clearances.

DIMENSIONS (CONT)

ROOF CURB DETAILS — 08-12 SIZE UNIT

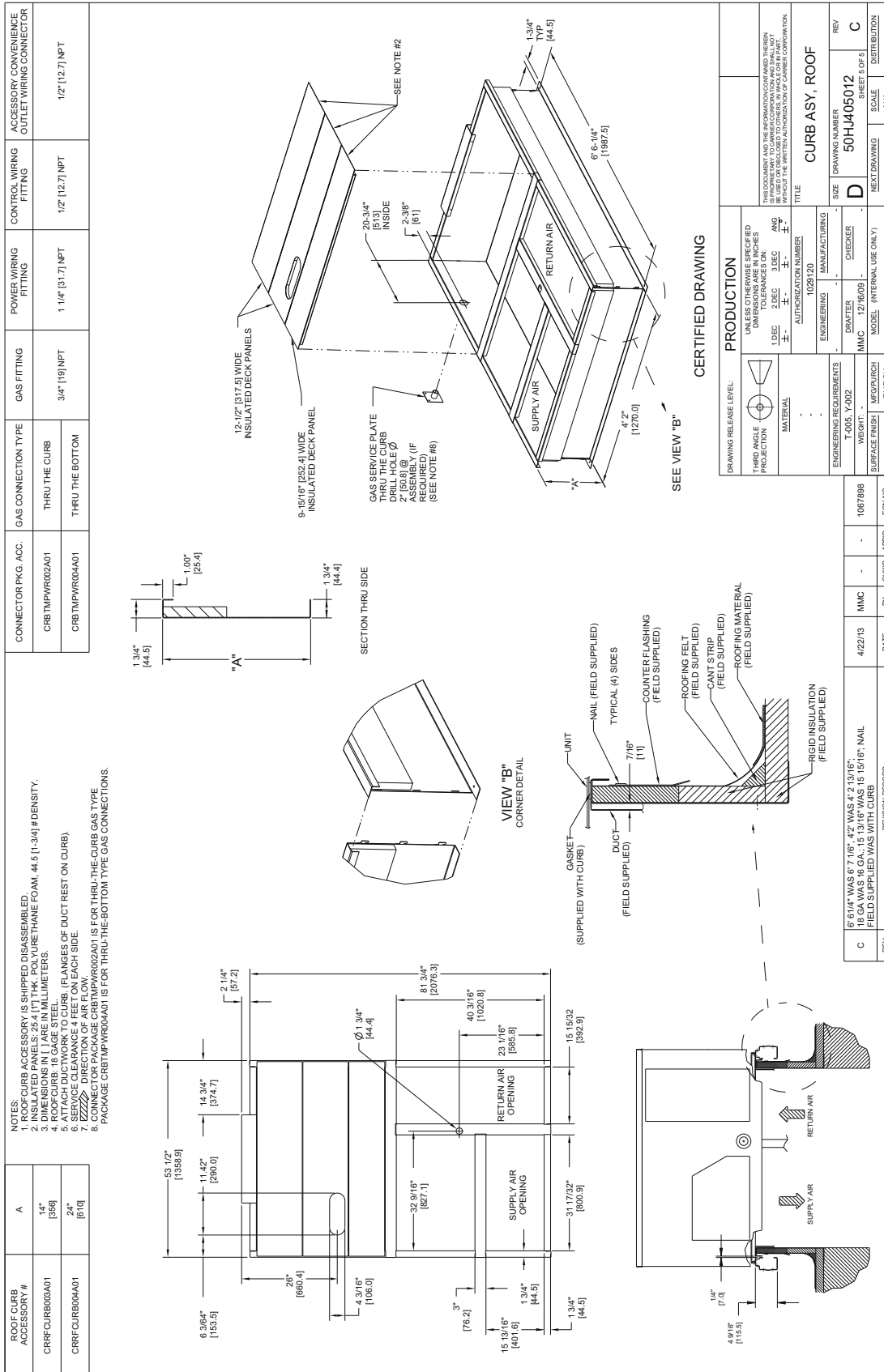

DIMENSIONS (CONT)

UNIT DIMENSIONAL DRAWING — 14 SIZE UNIT (cont)

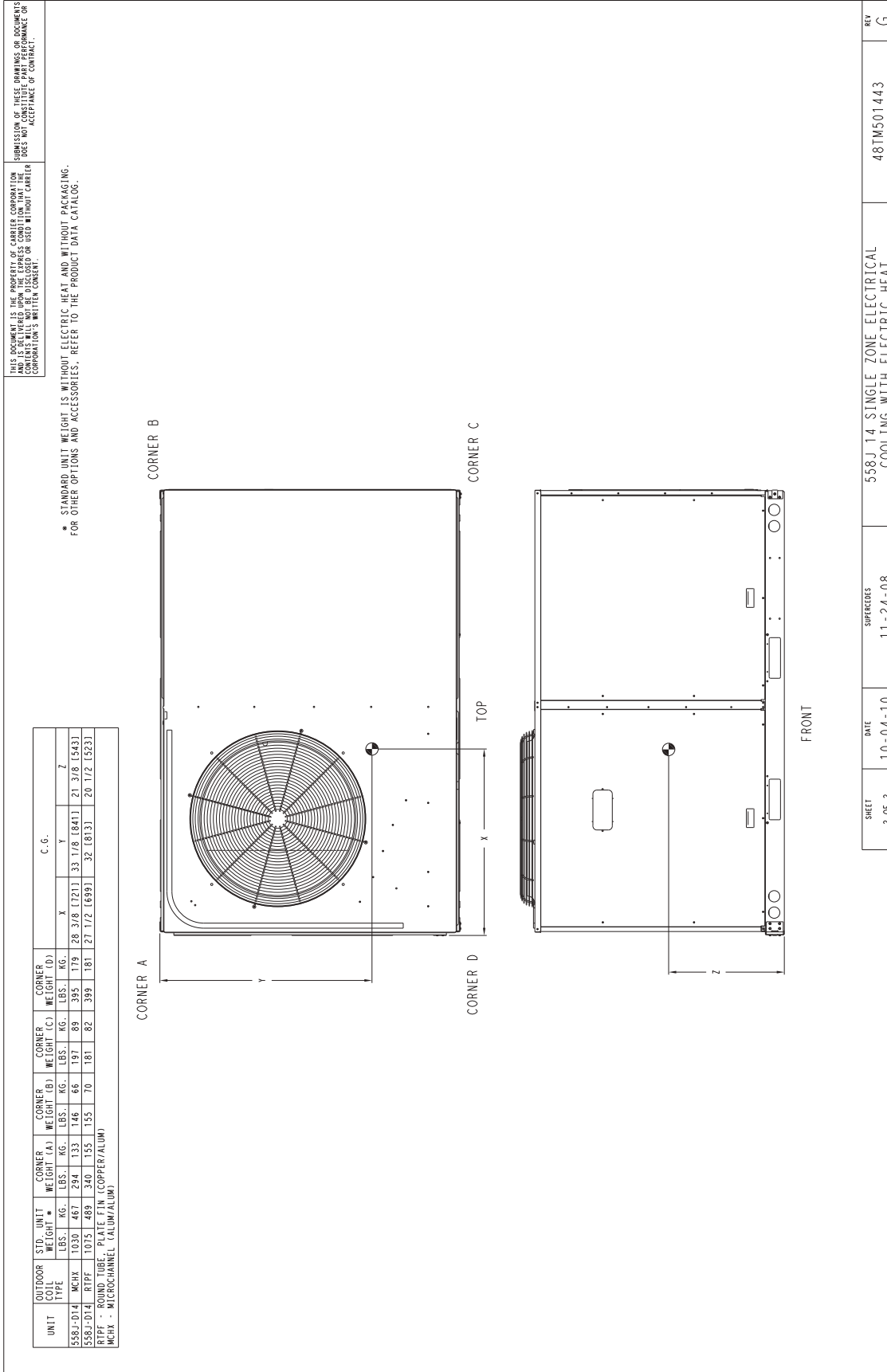

SERVICE CLEARANCE DIMENSIONAL DRAWING — 14 SIZE UNIT

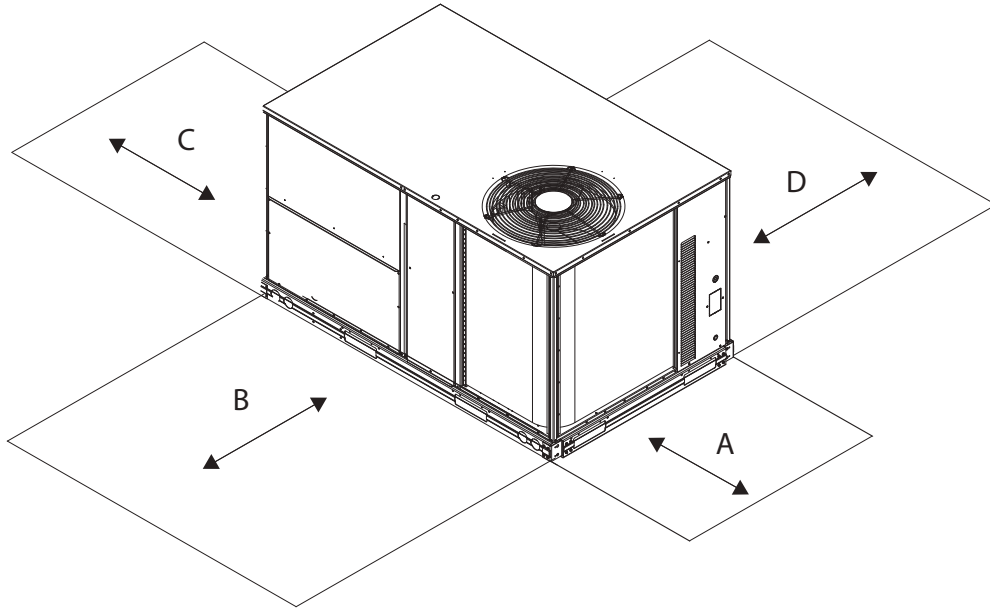

LOC	DIMENSION	CONDITION
A	48-in. (1219 mm) 18-in. (457 mm) 18-in. (457 mm) 12-in. (305 mm)	<ul style="list-style-type: none"> • Unit disconnect is mounted on panel • No disconnect, convenience outlet option • Recommended service clearance • Minimum clearance
B	42-in. (1067 mm) 36-in. (914 mm) Special	<ul style="list-style-type: none"> • Surface behind servicer is grounded (e.g., metal, masonry wall) • Surface behind servicer is electrically non-conductive (e.g., wood, fiberglass) • Check for sources of flue products within 10-ft of unit fresh air intake hood
C	36-in. (914 mm) 18-in. (457 mm)	<ul style="list-style-type: none"> • Side condensate drain is used • Minimum clearance
D	42-in. (1067 mm) 36-in. (914 mm)	<ul style="list-style-type: none"> • Surface behind servicer is grounded (e.g., metal, masonry wall, another unit) • Surface behind servicer is electrically non-conductive (e.g., wood, fiberglass)

NOTE: Unit not designed to have overhead obstruction.
Contact Application Engineering for guidance on any application planning overhead obstruction or vertical clearances.

DIMENSIONS (CONT)

UNIT DIMENSIONAL DRAWING — 16 SIZE UNIT

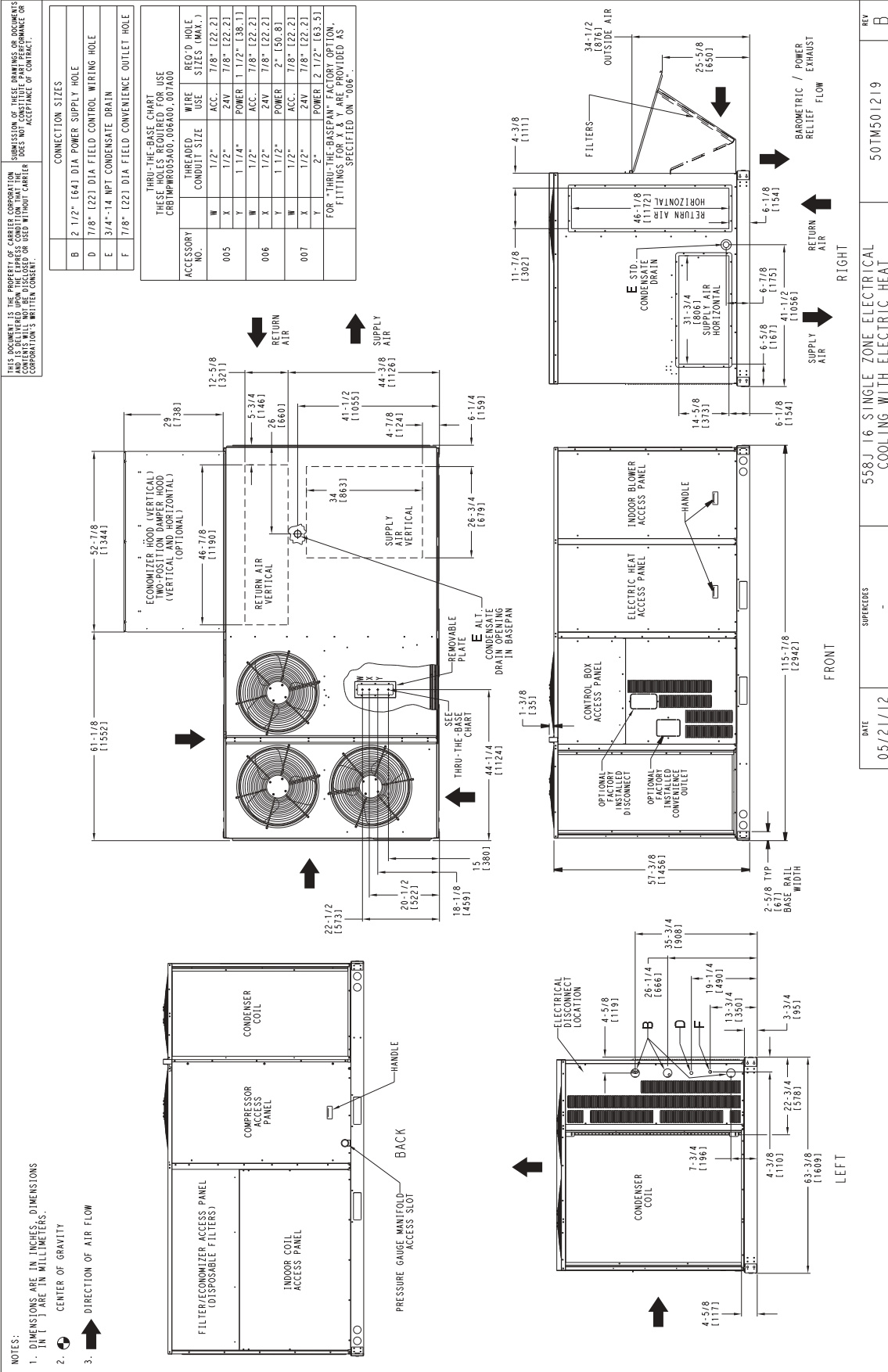

UNIT DIMENSIONAL DRAWING — 16 SIZE UNIT (cont)

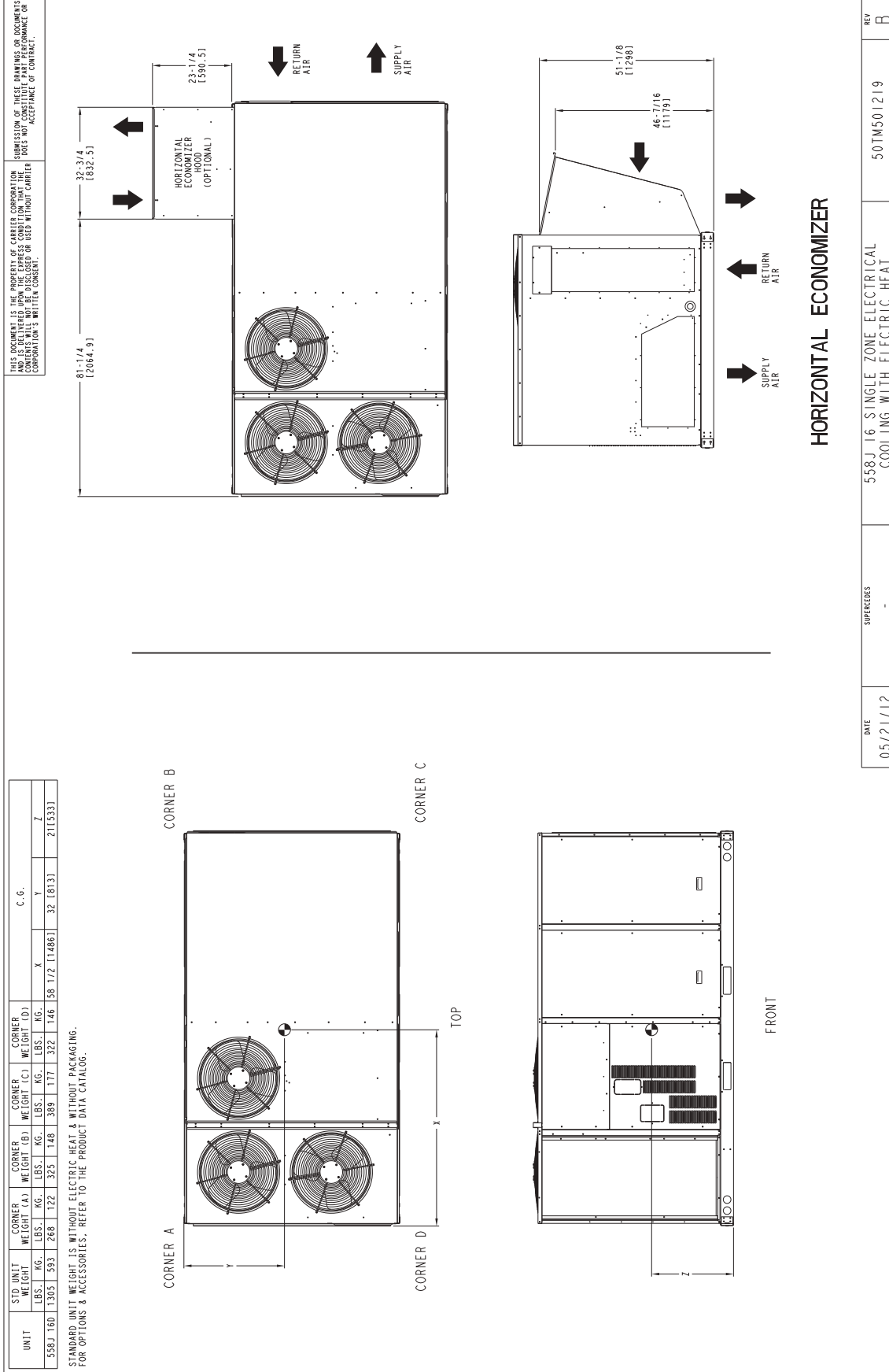

THIS DRAWING IS THE PROPERTY OF CARVER CORPORATION AND IS DELIVERED UPON THE EXPRESS CONDITION THAT THE CONTENTS WILL NOT BE DISCLOSED OR USED WITHOUT CARVER CORPORATION'S WRITTEN CONSENT.

558J 16D 1395 | 393 | 268 | 122 | 325 | 148 | 389 | 177 | 322 | 146 | 58 1/2 (1486) | 32 | (813) | 7 | 21(533)

UNIT	STD UNIT WEIGHT		CORNER WEIGHT (A)		CORNER WEIGHT (B)		CORNER WEIGHT (C)		CORNER WEIGHT (D)		C. G.			
	LBS.	KG.	LBS.	KG.	LBS.	KG.	LBS.	KG.	LBS.	KG.	X	Y	Z	
558J 16D	1395	393	268	122	325	148	389	177	322	146	58 1/2 (1486)	32	(813)	7
														21(533)

STANDARD UNIT WEIGHT IS WITHOUT ELECTRIC HEAT & WITHOUT PACKAGING. FOR OPTIONS & ACCESSORIES, REFER TO THE PRODUCT DATA CATALOG.

HORIZONTAL ECONOMIZER

DATE	05/21/12	SUPERCEDS	558J 16 SINGLE ZONE ELECTRICAL COOLING WITH ELECTRIC HEAT	50TMS01219	REV	B
------	----------	-----------	---	------------	-----	---

DIMENSIONS (CONT)

SERVICE CLEARANCE DIMENSIONAL DRAWING — 16 SIZE UNIT

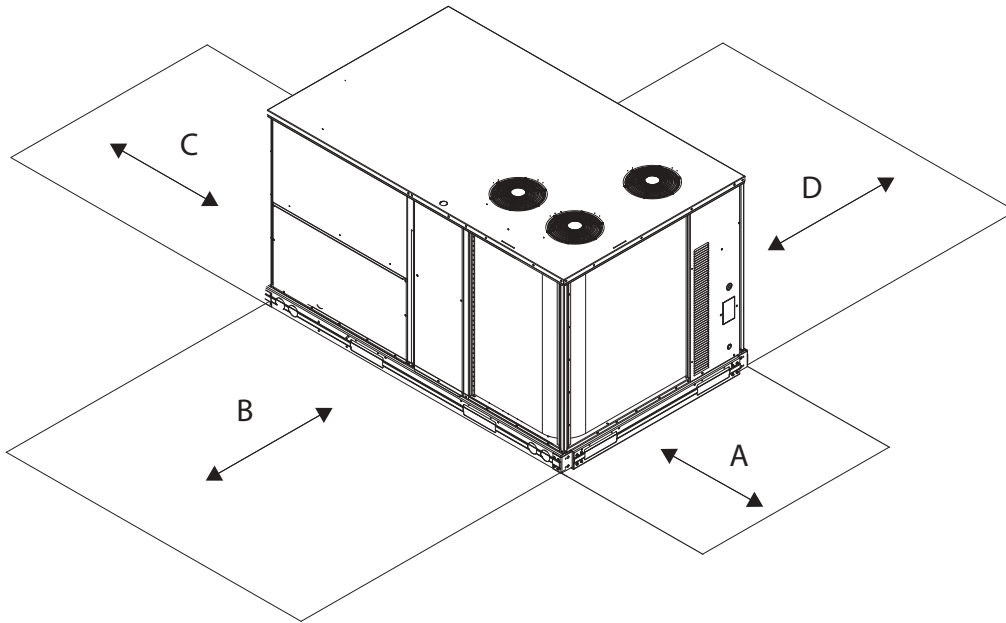

LOC	DIMENSION	CONDITION
A	48-in. (1219 mm) 18-in. (457 mm) 18-in. (457 mm) 12-in. (305 mm)	<ul style="list-style-type: none"> • Unit disconnect is mounted on panel • No disconnect, convenience outlet option • Recommended service clearance • Minimum clearance
B	42-in. (1067 mm) 36-in. (914 mm) Special	<ul style="list-style-type: none"> • Surface behind servicer is grounded (e.g., metal, masonry wall) • Surface behind servicer is electrically non-conductive (e.g., wood, fiberglass) • Check for sources of flue products within 10-ft of unit fresh air intake hood
C	36-in. (914 mm) 18-in. (457 mm)	<ul style="list-style-type: none"> • Side condensate drain is used • Minimum clearance
D	48-in. (1219 mm) 42-in. (1067 mm) 36-in. (914 mm) Special	<ul style="list-style-type: none"> • No flue discharge accessory installed, surface is combustible material • Surface behind servicer is grounded (e.g., metal, masonry wall, another unit) • Surface behind servicer is electrically non-conductive (e.g., wood, fiberglass) • Check for adjacent units or building fresh air intakes within 10-ft of this unit's flue outlet

NOTE: Unit not designed to have overhead obstruction.
Contact Application Engineering for guidance on any application planning overhead obstruction or vertical clearances.

ROOF CURB DETAILS — 16 SIZE UNIT

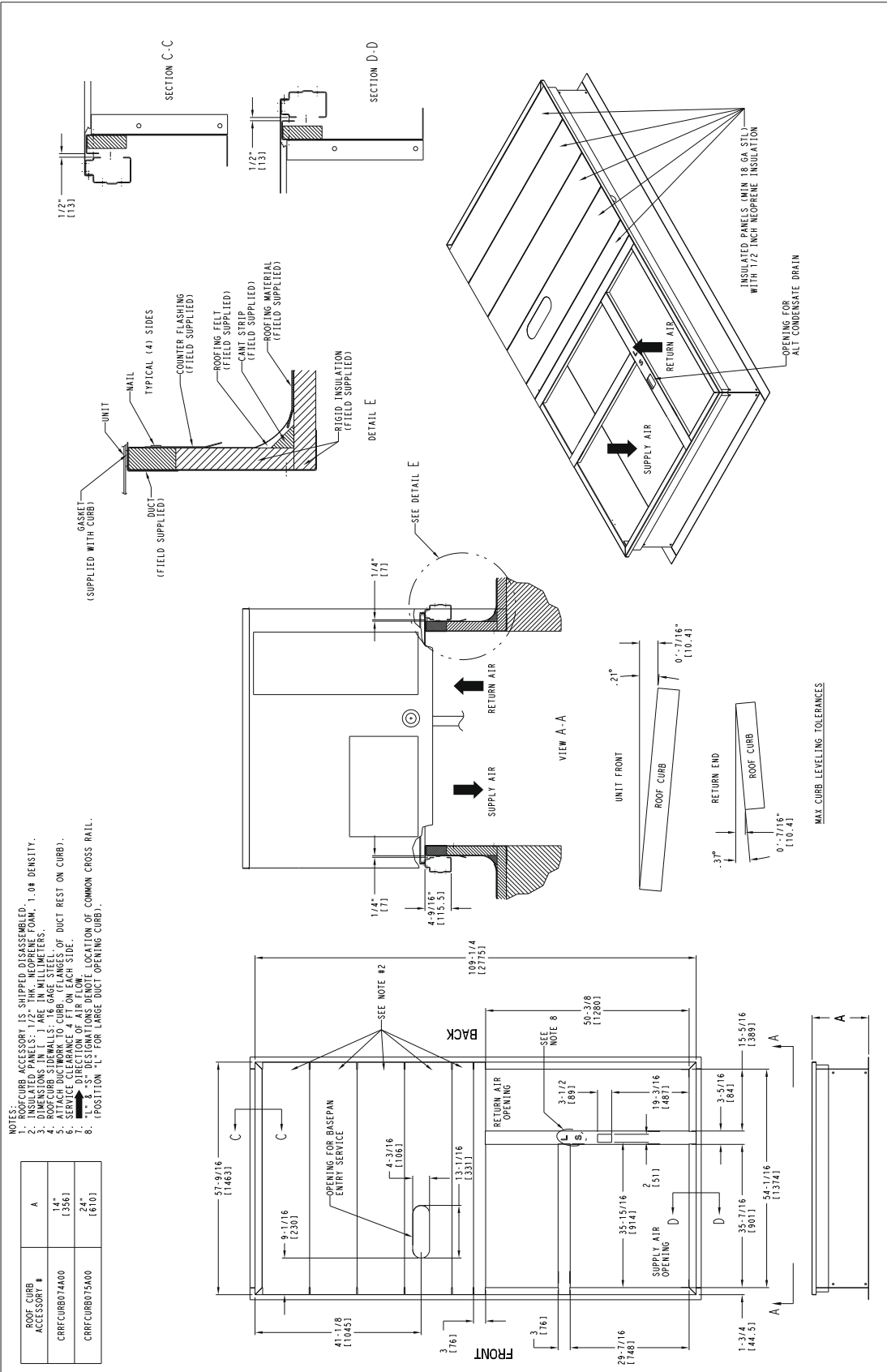

APPLICATION DATA

Min operating ambient temp (cooling)

In mechanical cooling mode, your Bryant rooftop unit can safely operate down to an outdoor ambient temperature of 40°F (4°C) and 25°F (-4°C), with an accessory winter start kit. It is possible to provide cooling at lower outdoor ambient temperatures by using less outside air, economizers, and/or accessory low ambient kits.

Max operating ambient temp (cooling)

The maximum operating ambient temperature for cooling mode is 115°F (46°C). While cooling operation above 115°F (46°C) may be possible, it could cause either a reduction in performance, reliability, or a protective action by the unit's internal safety devices.

Min and max airflow (cooling mode)

To maintain safe and reliable operation of your rooftop, operate within the cooling airflow limits. Operating above the max may cause blow-off, undesired airflow noise, or airflow related problems with the rooftop unit. Operating below the min may cause problems with coil freeze-up.

Heating-to-cooling changeover

Your unit will automatically change from heating to cooling mode when using a thermostat with an auto-change-over feature.

Airflow

All units are draw-through in cooling mode and blow-through in heating mode.

Outdoor air application strategies

Economizers reduce operating expenses and compressor run time by providing a free source of cooling and a means of ventilation to match application changing needs. In fact, they should be considered for most applications. Also, consider the various economizer control methods and their benefits, as well as sensors required to accomplish your application goals. Please contact your local Bryant representative for assistance.

Motor limits, brake horsepower (BHP)

Due to Bryant's internal unit design, air path, and specially designed motors, the full horsepower (maximum continuous BHP) band, as listed in the Physical Data tables, can be used with the utmost confidence. There is no need for extra safety factors, as Bryant's motors are designed and rigorously tested to use the entire, listed BHP range without either nuisance tripping or premature motor failure.

Sizing a rooftop

Bigger isn't necessarily better. While an air conditioner needs to have enough capacity to meet the design loads, it doesn't need excess capacity. In fact, excess capacity typically results in very poor part load performance and humidity control.

Using higher design temperatures than ASHRAE recommends for your location, adding "safety factors" to the calculated load, are all signs of oversizing air conditioners. Oversizing the air conditioner leads to poor humidity control, reduced efficiency, higher utility bills, larger indoor temperature swings, excessive noise, and increased wear and tear on the air conditioner.

Rather than oversizing an air conditioner, engineers should "right-size" or even slightly undersize air conditioners. Correctly sizing an air conditioner controls humidity better;

promotes efficiency; reduces utility bills; extends equipment life, and maintains even, comfortable temperatures. Please contact your local Bryant representative for assistance.

Low ambient applications

The optional Bryant economizer can adequately cool your space by bringing in fresh, cool outside air. In fact, when so equipped, accessory low-ambient kit may not be necessary. In low ambient conditions, unless the outdoor air is excessively humid or contaminated, economizer-based "free cooling" is the preferred less costly and energy conscious method. In low ambient applications where outside air might not be desired (such as contaminated or excessively humid outdoor environments), your Bryant rooftop can operate to ambient temperatures down to -20°F (-29°C) using the recommended accessory Motormaster® low ambient controller or down to 25°F (-4°C) with the field-installed Winter Start Package.

Winter start

Bryant's winter start kit extends the low ambient limit of your rooftop to 25°F (-4°C). The kit bypasses the low pressure switch, preventing nuisance tripping of the low pressure switch. Other low ambient precautions may still be prudent.

2-speed indoor fan motor system

Bryant's 2-speed indoor fan motor system has soft start capabilities to slowly ramp up the fan speeds, thus eliminating any high inrush air volume during initial start-up. It also has internal over current protection for the fan motor and a field-installed display kit that allows adjustment and in depth diagnostics if required.

The 2-speed fan motor system is factory preprogrammed and tested and requires no field adjustment to set up. The unit fan performance static pressure and cfm can be easily adjusted using the traditional means of belt drive pulley adjustments.

This 2-speed indoor fan motor system is available on models with 2-circuit/2-stage cooling (08-16 sizes) and 1-circuit/1-stage cooling (07 size). Operation with electro-mechanical or RTU Open (multi Protocol) controls. Both space sensor and conventional thermostats controls can be used to provide accurate control in any application.

NOTE: When using a 2-position or manual damper with the 2-speed indoor fan motor system, the damper will either over-ventilate or under-ventilate during certain modes of operation. Be aware the effects that ventilation rate has on leaving air temperatures. This becomes more noticeable in extreme temperatures (heating and cooling), since the unit is now treating a higher volume of outdoor air. In these scenarios, there are greater advantages of using an EconoMiSer® X, EconoMiSer2, or 3-Position Damper.

**558J 2-SPEED INDOOR FAN MOTOR SYSTEM -
VARIABLE FREQUENCY DRIVE (VFD) HP RATING**

MODEL SIZE	STATIC OPTION	VOLTAGE	VFD HP
07	STD	208/230	3.0
		460	3.0
		575	3.0
	MED	208/230	3.0
		460	3.0
		575	5.0
	HIGH	208/230	3.0
		460	5.0
		575	5.0
08	STD	208/230	3.0
		460	3.0
		575	3.0
	MED	208/230	3.0
		460	3.0
		575	5.0
	HIGH	208/230	7.5
		460	7.5
		575	7.5
09	STD	208/230	3.0
		460	3.0
		575	3.0
	MED	208/230	3.0
		460	3.0
		575	3.0
	HIGH	208/230	5.0
		460	5.0
		575	5.0
12	STD	208/230	3.0
		460	3.0
		575	3.0
	MED	208/230	5.0
		460	5.0
		575	5.0
	HIGH	208/230	7.5
		460	7.5
		575	7.5
14	STD	208/230	3.0
		460	3.0
		575	5.0
	MED	208/230	5.0
		460	5.0
		575	5.0
	HIGH	208/230	7.5
		460	7.5
		575	7.5
16	STD	208/230	3.0
		460	3.0
		575	5.0
	MED	208/230	5.0
		460	5.0
		575	5.0
	HIGH	208/230	7.5
		460	7.5
		575	7.5

Application/selection option

Selection software by Bryant saves time by performing many of the steps above. Contact your Bryant sales representative for assistance.

PERFORMANCE DATA

STATIC PRESSURE ADDERS (in. wg) — FACTORY OPTIONS AND/OR ACCESSORIES

Perfect Humidity™ Coil

6 TONS									
CFM	1000	1250	1500	1750	2000	2250	2500	2750	3000
6 Tons 1-Circuit/ 1-Stage Cooling	—	—	—	0.112	0.125	0.161	0.19	0.22	0.25

7.5 - 12.5 TONS																
CFM	2250	2500	2750	3000	3250	3500	3750	4000	4250	4500	4750	5000	5250	5500	5750	6000
7.5 Tons 2-Circuit/ 2-Stage Cooling	0.12	0.14	0.16	0.19	0.21	0.23	0.26	—	—	—	—	—	—	—	—	—
8.5 Tons 2-Circuit/ 2-Stage Cooling	—	0.11	0.12	0.13	0.15	0.17	0.18	0.20	0.22	—	—	—	—	—	—	—
10 Tons 2-Circuit/ 2-Stage Cooling	—	—	—	0.13	0.15	0.17	0.18	0.20	0.22	0.24	0.26	0.28	—	—	—	—
12.5 Tons 2-Circuit/ 2-Stage Cooling	—	—	—	—	—	0.17	0.18	0.20	0.22	0.24	0.26	0.28	0.31	0.33	0.36	0.39

15 TONS														
CFM	4000	4250	4500	4750	5000	5250	5500	5750	6000	6250	6500	6750	7000	7250
15 Tons 2-Circuit/ 2-Stage Cooling	0.06	0.07	0.07	0.08	0.08	0.09	0.10	0.10	0.11	0.12	0.12	0.13	0.14	0.15

ECONOMIZER, BAROMETRIC RELIEF AND PE PERFORMANCE — VERTICAL APPLICATION

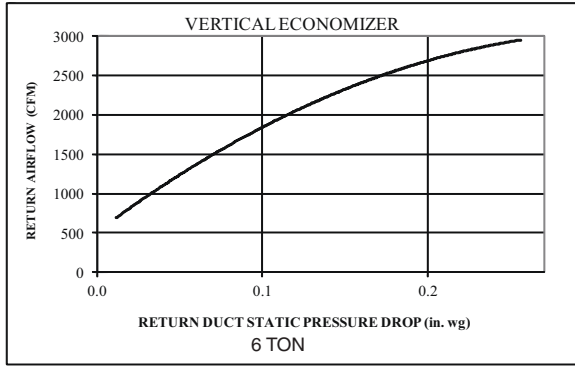

Return air pressure drop — vertical 6 tons

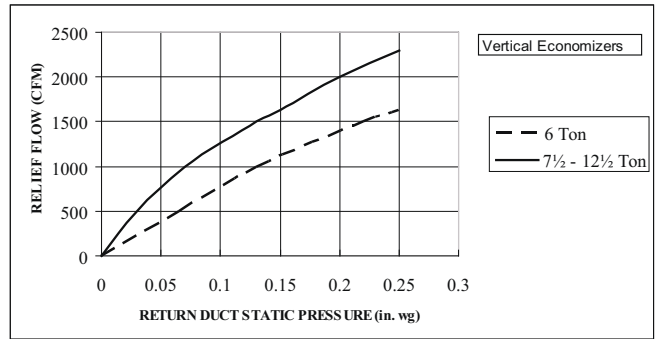

Barometric relief flow capacity — vertical 6 to 12 1/2 tons

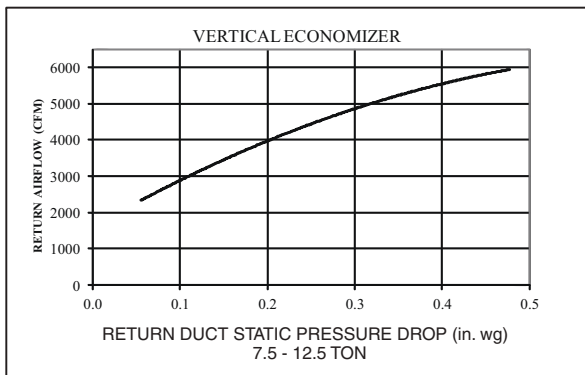

Return air pressure drop — vertical 7 1/2 to 12 1/2 tons

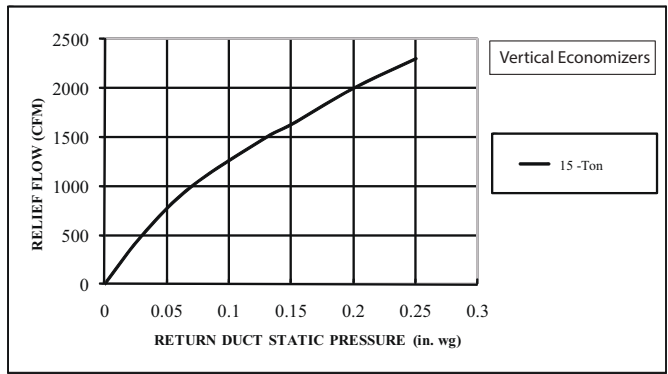

Barometric relief flow capacity - vertical 15 tons

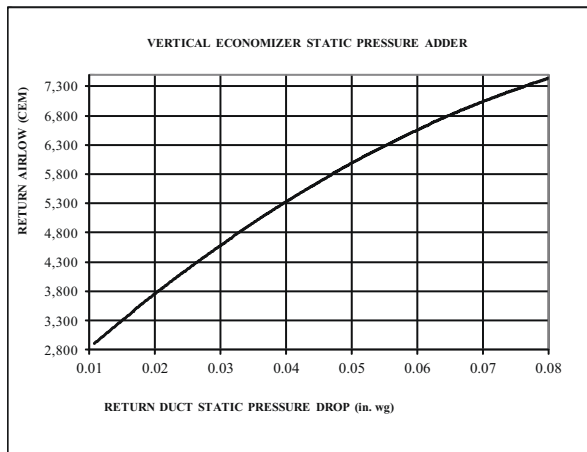

Return air pressure drop - vertical 15 tons

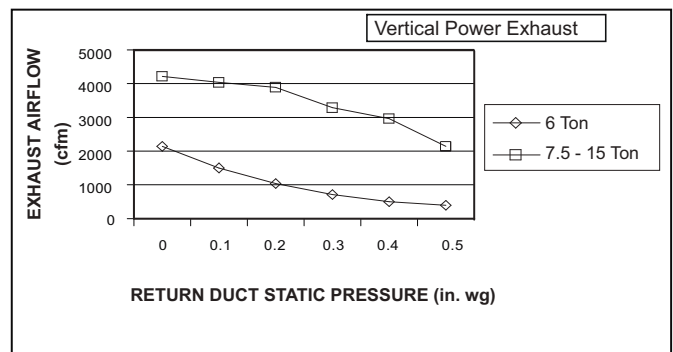

Vertical power exhaust performance

All data for both standard and ultra low leak models, where available.

PERFORMANCE DATA (CONT)

ECONOMIZER, BAROMETRIC RELIEF AND PE PERFORMANCE — HORIZONTAL APPLICATION

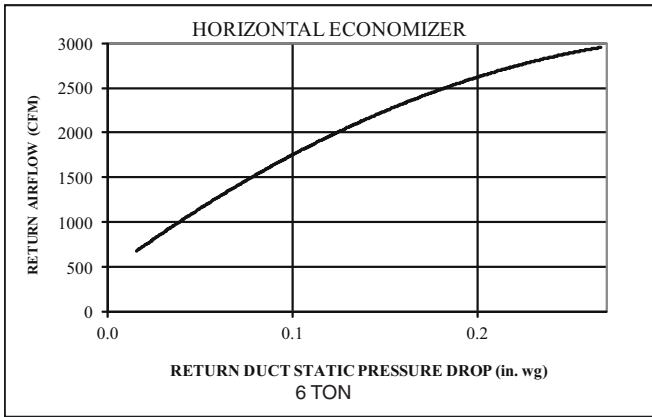

Return air pressure drop — horizontal 6 tons

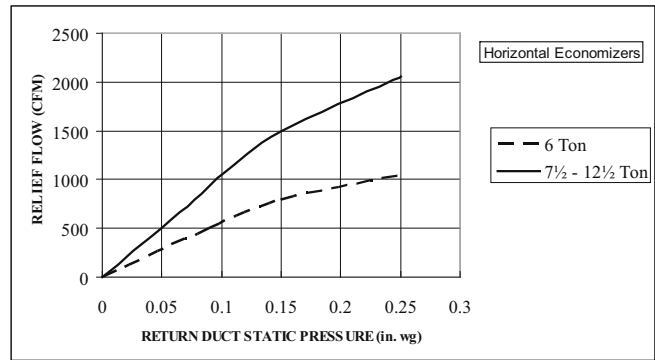

Barometric relief flow capacity — horizontal 6 to 12 1/2 tons

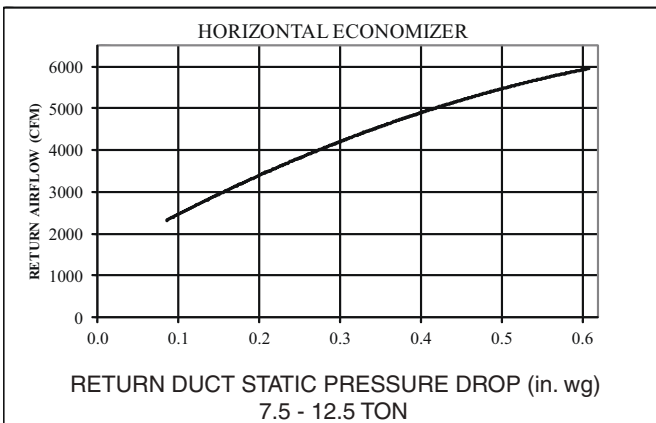

Return air pressure drop — horizontal 7 1/2 to 12 1/2 tons

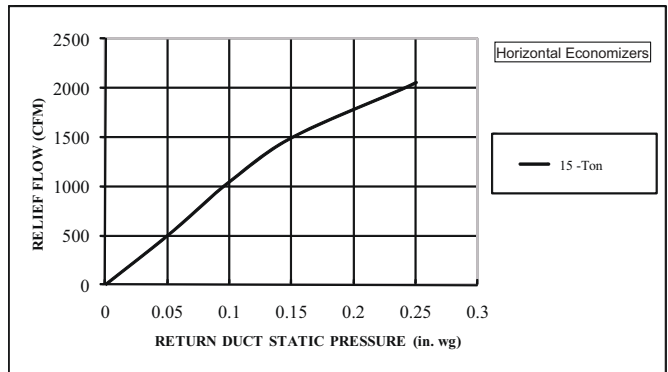

Barometric relief flow capacity — horizontal 15 tons

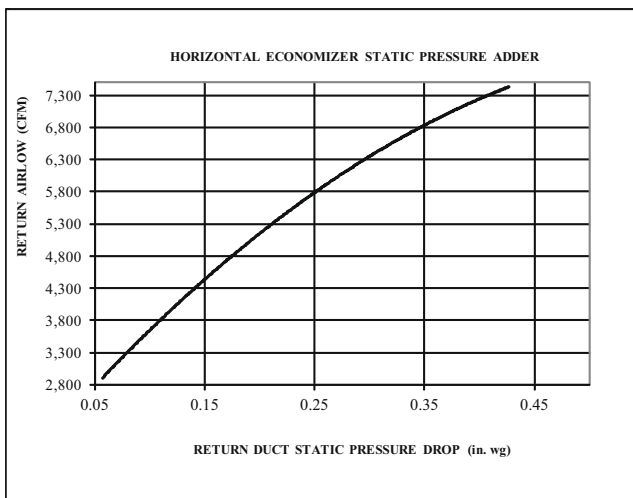

Return air pressure drop - horizontal 15 ton

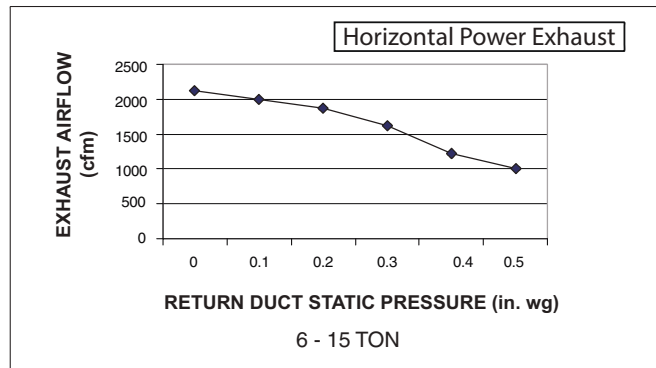

Horizontal power exhaust performance

GENERAL FAN PERFORMANCE NOTES

1. Interpolation is permissible. Do not extrapolate.
2. External static pressure is the static pressure difference between the return duct and the supply duct plus the static pressure caused by any factory-installed options (FIOPs) or accessories.
3. Tabular data accounts for pressure loss due to clean filters, high gas heat, unit casing, and wet coils. Factory options and accessories may add static pressure losses. Selection software is available, through your salesperson, to help you select the best motor/drive combination for your application.
4. The Fan Performance tables offer motor/drive recommendations. In cases when two motor/drive combinations would work, Bryant recommended the lower horsepower option.
5. For information on the electrical properties of Bryant motors, please see the Electrical information section of this book.
6. For more information on the performance limits of Bryant motors, see the application data section of this book.
7. The EPACT (Energy Policy Act of 1992) regulates energy requirements for specific types of indoor fan motors. Motors regulated by EPACT include any general purpose, T-frame (three-digit, 143 and larger), single-speed, foot mounted, polyphase, squirrel cage induction motors of NEMA (National Electrical Manufacturers Association) design A and B, manufactured for use in the United States. Ranging from 1 to 200 Hp, these continuous-duty motors operate on 230 and 460 volt, 60 Hz power. If a motor does not fit into these specifications, the motor does not have to be replaced by an EPACT compliant energy efficient motor. Variable speed motors are exempt from EPACT compliance requirements. Therefore, the indoor fan motors for Bryant 558J*07-16 units are exempt from these requirements.

PULLEY ADJUSTMENT

558J UNIT	MOTOR/DRIVE COMBO	MOTOR PULLEY TURNS OPEN (RPM)										
		0	0.5	1	1.5	2	2.5	3	3.5	4	4.5	5
07	Standard Static	1457	1419	1380	1342	1303	1265	1227	1188	1150	1111	1073
	Medium Static	1518	1484	1449	1415	1380	1346	1311	1277	1242	1208	1173
	High Static	1550	1542	1535	1527	1520	1512	1504	1497	1489	1482	1474
08	Standard Static	747	721	695	670	644	618	592	566	541	515	489
	Medium Static	949	927	906	884	863	841	819	798	776	755	733
	High Static*	1102	1083	1063	1044	1025	1006	986	967	948	928	909
09	Standard Static	733	712	690	669	647	626	604	583	561	540	518
	Medium Static	936	911	887	862	838	813	788	764	739	715	690
	High Static	1084	1059	1035	1010	986	961	936	912	887	863	838
12	Standard Static	838	813	789	764	739	715	690	665	640	616	591
	Medium Static	1084	1059	1035	1010	986	961	936	912	887	863	838
	High Static	1240	1218	1196	1175	1153	1131	1109	1087	1066	1044	1022
14	Standard Static	843	824	805	786	767	748	728	709	690	671	652
	Medium Static	1084	1059	1035	1010	986	961	936	912	887	863	838
	High Static	1240	1218	1196	1175	1153	1131	1109	1087	1066	1044	1022
16	Standard Static	676	659	642	625	608	592	575	558	541	524	507
	Medium Static	851	829	806	784	761	739	717	694	672	649	627
	High Static	955	937	919	901	883	866	848	830	812	794	776

* High static option not available on 558J*08N units.

NOTE: Do not adjust pulley further than 5 turns open.

— Factory settings

PERFORMANCE DATA (CONT)

558J*07 HORIZONTAL UNIT — 6 TON
(For more information, see General Fan Performance Notes on page 49.)

CFM	Available External Static Pressure (in. wg)																			
	0.2		0.4		0.6		0.8		1.0		1.2		1.4		1.6		1.8		2.0	
	RPM	BHP	RPM	BHP	RPM	BHP	RPM	BHP	RPM	BHP	RPM	BHP	RPM	BHP	RPM	BHP	RPM	BHP	RPM	BHP
1800	822	0.51	927	0.66	1018	0.82	1100	0.98	1174	1.15	1244	1.33	1308	1.51	1369	1.70	1427	1.90	1483	2.10
1950	872	0.62	973	0.79	1061	0.95	1140	1.13	1213	1.31	1281	1.49	1345	1.68	1405	1.88	1462	2.09	1517	2.30
2100	923	0.75	1019	0.92	1104	1.10	1182	1.29	1253	1.48	1320	1.67	1382	1.87	1441	2.08	1498	2.29	—	—
2250	974	0.90	1067	1.08	1149	1.27	1224	1.46	1294	1.66	1359	1.87	1420	2.08	1479	2.29	1534	2.51	—	—
2400	1026	1.06	1115	1.26	1195	1.46	1268	1.66	1336	1.87	1400	2.09	1460	2.31	1517	2.53	—	—	—	—
2550	1079	1.25	1164	1.46	1241	1.67	1312	1.88	1379	2.10	1441	2.33	1500	2.55	—	—	—	—	—	—
2700	1132	1.46	1214	1.67	1289	1.90	1358	2.12	1422	2.35	1483	2.59	1541	2.83	—	—	—	—	—	—
2850	1186	1.69	1264	1.92	1336	2.15	1404	2.39	1467	2.63	1527	2.87	—	—	—	—	—	—	—	—
3000	1240	1.94	1315	2.18	1385	2.43	1451	2.68	1512	2.93	—	—	—	—	—	—	—	—	—	—

- Standard static 1073-1457 RPM, 2.4 Max BHP
- Medium static 1173-1518 RPM, 2.9 Max BHP
- High static 1474-1550 RPM, 3.7 Max BHP

558J*07 VERTICAL UNIT — 6 TON
(For more information, see General Fan Performance Notes on page 49.)

CFM	Available External Static Pressure (in. wg)																			
	0.2		0.4		0.6		0.8		1.0		1.2		1.4		1.6		1.8		2.0	
	RPM	BHP	RPM	BHP	RPM	BHP	RPM	BHP	RPM	BHP	RPM	BHP	RPM	BHP	RPM	BHP	RPM	BHP	RPM	BHP
1800	907	0.63	1006	0.80	1092	0.97	1169	1.14	1239	1.32	1304	1.51	1365	1.69	1422	1.88	1477	2.08	1528	2.28
1950	965	0.77	1060	0.95	1143	1.13	1218	1.32	1287	1.51	1350	1.71	1410	1.91	1467	2.11	1520	2.31	—	—
2100	1024	0.93	1115	1.12	1195	1.32	1268	1.52	1335	1.72	1398	1.93	1457	2.14	1512	2.35	—	—	—	—
2250	1083	1.11	1170	1.32	1248	1.53	1319	1.74	1385	1.96	1446	2.18	1504	2.40	—	—	—	—	—	—
2400	1143	1.32	1227	1.54	1302	1.76	1371	1.99	1435	2.22	1496	2.45	—	—	—	—	—	—	—	—
2550	1203	1.55	1284	1.78	1357	2.02	1424	2.26	1487	2.50	1546	2.75	—	—	—	—	—	—	—	—
2700	1264	1.81	1342	2.06	1412	2.31	1478	2.56	1539	2.82	—	—	—	—	—	—	—	—	—	—
2850	1326	2.09	1400	2.36	1469	2.62	1532	2.89	—	—	—	—	—	—	—	—	—	—	—	—
3000	1387	2.41	1459	2.69	1525	2.97	—	—	—	—	—	—	—	—	—	—	—	—	—	—

- Standard static 1073-1457 RPM, 2.4 Max BHP
- Medium static 1173-1518 RPM, 2.9 Max BHP
- High static 1474-1550 RPM, 3.7 Max BHP

558J*08 HORIZONTAL UNIT — 7.5 TON
(For more information, see General Fan Performance Notes on page 49.)

CFM	Available External Static Pressure (in. wg)																			
	0.2		0.4		0.6		0.8		1.0		1.2		1.4		1.6		1.8		2.0	
	RPM	BHP	RPM	BHP	RPM	BHP	RPM	BHP	RPM	BHP	RPM	BHP	RPM	BHP	RPM	BHP	RPM	BHP	RPM	BHP
2250	465	0.43	555	0.64	629	0.86	694	1.10	753	1.34	806	1.60	856	1.87	903	2.15	947	2.45	988	2.75
2438	488	0.51	575	0.73	648	0.97	712	1.21	769	1.47	822	1.74	872	2.03	918	2.32	961	2.62	1003	2.93
2625	510	0.60	595	0.84	666	1.09	729	1.34	786	1.62	839	1.90	887	2.19	933	2.49	977	2.81	1018	3.13
2813	533	0.70	616	0.95	686	1.22	748	1.49	804	1.77	856	2.06	904	2.37	949	2.68	992	3.01	1033	3.34
3000	557	0.82	637	1.08	705	1.36	766	1.64	822	1.94	873	2.24	921	2.56	966	2.89	1008	3.22	1049	3.56
3188	581	0.94	659	1.23	726	1.51	785	1.81	840	2.12	891	2.44	938	2.77	982	3.10	1025	3.45	1065	3.81
3375	606	1.08	681	1.38	746	1.68	805	2.00	859	2.32	909	2.65	955	2.99	1000	3.34	1041	3.70	1081	4.06
3563	630	1.24	703	1.55	767	1.87	825	2.20	878	2.53	927	2.88	973	3.23	1017	3.59	1059	3.96	1098	4.34
3750	655	1.41	726	1.74	789	2.07	845	2.41	897	2.76	946	3.12	992	3.48	1035	3.86	1076	4.24	1115	4.63

- Standard static 489-747 RPM, 1.7 Max BHP
- Medium static 733-949 RPM, 2.9 Max BHP
- High static 909-1102 RPM, 4.7 Max BHP
- BOLD** — Indicated field-supplied drive.

558J*08 VERTICAL UNIT — 7.5 TON
(For more information, see General Fan Performance Notes on page 49.)

CFM	Available External Static Pressure (in. wg)																			
	0.2		0.4		0.6		0.8		1.0		1.2		1.4		1.6		1.8		2.0	
	RPM	BHP	RPM	BHP	RPM	BHP	RPM	BHP	RPM	BHP	RPM	BHP	RPM	BHP	RPM	BHP	RPM	BHP	RPM	BHP
2250	511	0.53	591	0.73	660	0.95	722	1.19	779	1.44	832	1.71	882	1.99	928	2.29	973	2.59	1015	2.92
2438	540	0.64	616	0.85	683	1.08	743	1.33	799	1.59	851	1.87	899	2.16	945	2.46	989	2.78	1031	3.11
2625	569	0.76	642	0.99	706	1.23	765	1.49	819	1.76	870	2.04	918	2.34	963	2.66	1006	2.98	1048	3.32
2813	599	0.90	669	1.14	731	1.39	788	1.66	841	1.94	890	2.24	937	2.55	982	2.87	1024	3.21	1065	3.55
3000	630	1.06	696	1.31	756	1.58	811	1.86	863	2.15	912	2.46	958	2.78	1001	3.11	1043	3.45	1083	3.80
3188	661	1.23	724	1.50	782	1.78	836	2.07	886	2.38	934	2.69	979	3.02	1022	3.36	1063	3.72	1102	4.08
3375	692	1.43	753	1.71	809	2.00	861	2.31	910	2.62	956	2.95	1000	3.29	1042	3.64	1083	4.00	1122	4.38
3563	723	1.65	782	1.94	836	2.25	887	2.56	934	2.89	980	3.23	1023	3.58	1064	3.94	1104	4.32	1142	4.70
3750	755	1.89	811	2.20	864	2.52	913	2.84	959	3.18	1004	3.54	1046	3.90	1086	4.27	1125	4.65	—	—

- Standard static 489-747 RPM, 1.7 Max BHP
- Medium static 733-949 RPM, 2.9 Max BHP
- High static 909-1102 RPM, 4.7 Max BHP
- BOLD** — Indicated field-supplied drive.

***09 HORIZONTAL UNIT — 8.5 TON**
(For more information, see General Fan Performance Notes on page 49.)

CFM	Available External Static Pressure (in. wg)																			
	0.2		0.4		0.6		0.8		1.0		1.2		1.4		1.6		1.8		2.0	
	RPM	BHP	RPM	BHP	RPM	BHP	RPM	BHP	RPM	BHP	RPM	BHP	RPM	BHP	RPM	BHP	RPM	BHP	RPM	BHP
2550	438	0.39	523	0.50	595	0.64	658	0.78	716	0.94	769	1.11	819	1.30	865	1.49	909	1.70	951	1.92
2763	459	0.47	541	0.60	611	0.73	673	0.88	730	1.05	782	1.22	831	1.41	877	1.60	921	1.81	963	2.04
2975	481	0.56	560	0.70	628	0.84	689	1.00	745	1.16	796	1.34	845	1.53	890	1.73	933	1.94	974	2.16
3188	504	0.67	580	0.82	646	0.97	705	1.13	760	1.30	811	1.48	858	1.67	903	1.88	946	2.09	987	2.31
3400	526	0.80	600	0.95	664	1.11	722	1.27	776	1.45	826	1.63	873	1.83	917	2.04	959	2.25	1000	2.48
3613	550	0.94	620	1.10	683	1.26	740	1.43	793	1.62	842	1.81	888	2.01	932	2.22	973	2.44	1013	2.67
3825	573	1.09	641	1.26	702	1.43	758	1.61	810	1.80	858	2.00	903	2.20	946	2.42	988	2.64	1027	2.87
4038	597	1.26	663	1.44	722	1.62	777	1.81	827	2.00	875	2.20	919	2.41	962	2.63	1002	2.86	1041	3.10
4250	621	1.45	685	1.64	743	1.83	796	2.02	845	2.22	892	2.43	936	2.65	978	2.87	1018	3.10	1056	3.34

- Standard static 518-733 RPM, 1.7 Max BHP
- Medium static 690-936 RPM, 2.4 Max BHP
- High static 838-1084 RPM, 3.7 Max BHP

558J*09 VERTICAL UNIT — 8.5 TON
(For more information, see General Fan Performance Notes on page 49.)

CFM	Available External Static Pressure (in. wg)																			
	0.2		0.4		0.6		0.8		1.0		1.2		1.4		1.6		1.8		2.0	
	RPM	BHP	RPM	BHP	RPM	BHP	RPM	BHP	RPM	BHP	RPM	BHP	RPM	BHP	RPM	BHP	RPM	BHP	RPM	BHP
2550	477	0.43	556	0.57	624	0.71	685	0.85	742	0.99	794	1.14	842	1.29	888	1.44	932	1.59	973	1.75
2763	503	0.52	578	0.67	644	0.82	704	0.97	759	1.13	810	1.28	858	1.44	903	1.60	946	1.77	987	1.93
2975	529	0.62	601	0.79	665	0.95	724	1.11	777	1.28	827	1.44	874	1.61	919	1.78	961	1.95	1001	2.13
3188	556	0.74	625	0.92	687	1.09	744	1.26	796	1.44	845	1.62	891	1.79	935	1.98	977	2.16	1017	2.34
3400	583	0.88	650	1.06	710	1.24	765	1.43	816	1.62	864	1.80	909	1.99	952	2.18	993	2.38	1033	2.57
3613	611	1.03	675	1.22	733	1.42	787	1.61	836	1.81	883	2.01	928	2.21	970	2.41	1010	2.61	1049	2.82
3825	639	1.19	701	1.40	757	1.61	809	1.81	857	2.02	903	2.23	947	2.44	988	2.65	1028	2.87	1066	3.08
4038	668	1.38	727	1.60	781	1.81	832	2.03	879	2.25	924	2.47	967	2.70	1008	2.92	1047	3.14	1084	3.37
4250	696	1.58	753	1.81	806	2.04	855	2.27	901	2.50	945	2.73	987	2.97	1027	3.20	1066	3.43	1103	3.67

- Standard static 518-733 RPM, 1.7 Max BHP
- Medium static 690-936 RPM, 2.4 Max BHP
- High static 838-1084 RPM, 3.7 Max BHP

PERFORMANCE DATA (CONT)

558J*12 HORIZONTAL UNIT — 10 TON
(For more information, see General Fan Performance Notes on page 49.)

CFM	Available External Static Pressure (in. wg)																			
	0.2		0.4		0.6		0.8		1.0		1.2		1.4		1.6		1.8		2.0	
	RPM	BHP	RPM	BHP	RPM	BHP	RPM	BHP	RPM	BHP	RPM	BHP	RPM	BHP	RPM	BHP	RPM	BHP	RPM	BHP
3000	523	0.58	592	0.73	657	0.88	718	1.05	775	1.22	830	1.39	883	1.57	934	1.76	982	1.95	1029	2.14
3250	555	0.71	620	0.87	681	1.04	739	1.21	794	1.39	847	1.57	897	1.76	946	1.96	993	2.16	1039	2.36
3500	588	0.86	649	1.03	707	1.21	762	1.39	815	1.58	865	1.77	914	1.97	961	2.18	1007	2.38	1051	2.60
3750	621	1.03	679	1.21	734	1.40	786	1.59	837	1.79	885	1.99	932	2.20	978	2.42	1022	2.64	1065	2.86
4000	655	1.23	709	1.42	761	1.61	812	1.82	860	2.03	907	2.24	952	2.46	996	2.68	1038	2.91	1080	3.14
4250	689	1.45	741	1.65	790	1.86	838	2.07	885	2.29	930	2.51	973	2.74	1015	2.97	1057	3.21	1097	3.45
4500	723	1.69	773	1.90	820	2.12	866	2.35	910	2.57	954	2.81	996	3.05	1037	3.29	1076	3.54	1115	3.79
4750	758	1.96	805	2.19	850	2.42	894	2.65	937	2.89	979	3.13	1019	3.38	1059	3.63	1097	3.89	1135	4.15
5000	793	2.26	838	2.50	881	2.74	923	2.98	965	3.23	1005	3.49	1044	3.74	1082	4.01	1119	4.27	1156	4.55

- Standard static 591-838 RPM, 2.4 Max BHP
- Medium static 838-1084 RPM, 3.7 Max BHP
- High static 1022-1240 RPM, 4.7 Max BHP

558J*12 VERTICAL UNIT — 10 TON
(For more information, see General Fan Performance Notes on page 49.)

CFM	Available External Static Pressure (in. wg)																			
	0.2		0.4		0.6		0.8		1.0		1.2		1.4		1.6		1.8		2.0	
	RPM	BHP	RPM	BHP	RPM	BHP	RPM	BHP	RPM	BHP	RPM	BHP	RPM	BHP	RPM	BHP	RPM	BHP	RPM	BHP
3000	556	0.65	623	0.80	684	0.95	738	1.11	789	1.26	836	1.42	881	1.57	923	1.73	963	1.89	1001	2.05
3250	590	0.79	655	0.96	713	1.13	766	1.29	815	1.46	861	1.63	904	1.79	945	1.96	985	2.13	1023	2.30
3500	625	0.96	687	1.14	742	1.32	794	1.50	841	1.68	886	1.86	929	2.04	969	2.22	1008	2.40	1045	2.58
3750	661	1.16	719	1.35	773	1.54	822	1.73	869	1.93	912	2.12	954	2.31	994	2.50	1031	2.70	1068	2.89
4000	697	1.37	753	1.58	804	1.79	852	1.99	897	2.20	940	2.40	980	2.61	1019	2.81	1056	3.02	1092	3.22
4250	733	1.62	787	1.84	836	2.06	883	2.28	926	2.49	968	2.71	1007	2.93	1045	3.15	1081	3.36	1117	3.58
4500	770	1.89	821	2.13	869	2.36	914	2.59	956	2.82	996	3.05	1035	3.28	1072	3.51	1108	3.74	1142	3.97
4750	807	2.20	856	2.45	902	2.69	945	2.94	986	3.18	1026	3.42	1063	3.66	1100	3.91	1135	4.15	1168	4.39
5000	844	2.54	891	2.80	936	3.06	978	3.31	1018	3.57	1056	3.82	1093	4.08	1128	4.34	1162	4.59	—	—

- Standard static 591-838 RPM, 2.4 Max BHP
- Medium static 838-1084 RPM, 3.7 Max BHP
- High static 1022-1240 RPM, 4.7 Max BHP

558J*14 HORIZONTAL UNIT — 12.5 TON
(For more information, see General Fan Performance Notes on page 49.)

CFM	Available External Static Pressure (in. wg)																			
	0.2		0.4		0.6		0.8		1.0		1.2		1.4		1.6		1.8		2.0	
	RPM	BHP	RPM	BHP	RPM	BHP	RPM	BHP	RPM	BHP	RPM	BHP	RPM	BHP	RPM	BHP	RPM	BHP	RPM	BHP
3438	580	0.82	642	0.99	700	1.16	756	1.34	809	1.53	860	1.72	910	1.92	957	2.12	1003	2.32	1048	2.54
3750	621	1.03	679	1.21	734	1.40	786	1.59	837	1.79	885	1.99	932	2.20	978	2.42	1022	2.64	1065	2.86
4063	663	1.28	717	1.47	769	1.67	818	1.88	866	2.09	912	2.31	957	2.53	1001	2.75	1043	2.98	1084	3.22
4375	706	1.56	757	1.77	805	1.98	852	2.20	897	2.43	941	2.66	984	2.89	1026	3.13	1066	3.37	1106	3.62
4688	749	1.89	797	2.11	843	2.34	887	2.57	930	2.81	972	3.05	1013	3.29	1053	3.54	1092	3.80	1130	4.06
5000	793	2.26	838	2.50	881	2.74	923	2.98	965	3.23	1005	3.49	1044	3.74	1082	4.01	1119	4.27	1156	4.55
5313	837	2.69	880	2.93	921	3.19	961	3.44	1000	3.71	1038	3.97	1076	4.24	1113	4.52	—	—	—	—
5625	882	3.16	922	3.42	961	3.68	999	3.95	1037	4.23	1073	4.51	—	—	—	—	—	—	—	—
5938	926	3.68	964	3.96	1001	4.23	1038	4.52	—	—	—	—	—	—	—	—	—	—	—	—
6250	971	4.26	1007	4.55	—	—	—	—	—	—	—	—	—	—	—	—	—	—	—	—

- Standard static 652-843 RPM, 2.9 Max BHP
- Medium static 838-1084 RPM, 3.7 Max BHP
- High static 1022-1240 RPM, 4.7 Max BHP
- BOLD** — Indicated field-supplied drive.

558J*14 VERTICAL UNIT — 12.5 TON
(For more information, see General Fan Performance Notes on page 49.)

CFM	Available External Static Pressure (in. wg)																			
	0.2		0.4		0.6		0.8		1.0		1.2		1.4		1.6		1.8		2.0	
	RPM	BHP	RPM	BHP	RPM	BHP	RPM	BHP	RPM	BHP	RPM	BHP	RPM	BHP	RPM	BHP	RPM	BHP	RPM	BHP
3438	616	0.92	679	1.10	735	1.27	786	1.45	835	1.62	880	1.80	922	1.98	963	2.15	1002	2.33	1039	2.51
3750	661	1.16	719	1.35	773	1.54	822	1.73	869	1.93	912	2.12	954	2.31	994	2.50	1031	2.70	1068	2.89
4063	706	1.43	761	1.64	812	1.85	860	2.06	904	2.27	947	2.48	987	2.68	1025	2.89	1062	3.10	1098	3.31
4375	752	1.75	804	1.98	852	2.20	898	2.43	941	2.65	982	2.88	1021	3.10	1058	3.32	1094	3.55	1129	3.77
4688	798	2.12	847	2.36	894	2.60	937	2.85	979	3.09	1018	3.33	1056	3.57	1093	3.81	1128	4.04	1162	4.29
5000	844	2.54	891	2.80	936	3.06	978	3.31	1018	3.57	1056	3.82	1093	4.08	1128	4.34	1162	4.59	—	—
5313	891	3.01	936	3.28	978	3.56	1019	3.83	1057	4.11	1094	4.38	1130	4.65	—	—	—	—	—	—
5625	938	3.53	981	3.83	1022	4.12	1060	4.41	1097	4.70	—	—	—	—	—	—	—	—	—	—
5938	986	4.12	1026	4.43	—	—	—	—	—	—	—	—	—	—	—	—	—	—	—	—
6250	—	—	—	—	—	—	—	—	—	—	—	—	—	—	—	—	—	—	—	—

- Standard static 652-843 RPM, 2.9 Max BHP
- Medium static 838-1084 RPM, 3.7 Max BHP
- High static 1022-1240 RPM, 4.7 Max BHP
- BOLD** — Indicated field-supplied drive.

558J*16 HORIZONTAL UNIT — 15 TON
(For more information, see General Fan Performance Notes on page 49.)

CFM	Available External Static Pressure (in. wg)																			
	0.2		0.4		0.6		0.8		1.0		1.2		1.4		1.6		1.8		2.0	
	RPM	BHP	RPM	BHP	RPM	BHP	RPM	BHP	RPM	BHP	RPM	BHP	RPM	BHP	RPM	BHP	RPM	BHP	RPM	BHP
4500	423	0.77	487	0.99	545	1.22	601	1.47	655	1.73	707	2.02	758	2.33	806	2.66	853	3.01	898	3.37
4875	447	0.94	507	1.18	563	1.42	615	1.67	666	1.95	716	2.24	764	2.55	811	2.89	856	3.24	900	3.61
5250	471	1.13	528	1.38	581	1.64	631	1.91	679	2.19	726	2.49	772	2.81	817	3.14	860	3.50	903	3.87
5625	496	1.35	550	1.62	600	1.89	648	2.17	694	2.46	738	2.77	782	3.09	825	3.43	867	3.79	908	4.17
6000	520	1.59	572	1.88	620	2.17	666	2.46	710	2.76	752	3.08	794	3.41	835	3.76	875	4.12	914	4.50
6375	545	1.86	594	2.17	640	2.47	684	2.78	726	3.10	767	3.42	807	3.76	846	4.12	885	4.49	923	4.87
6750	571	2.17	617	2.48	661	2.81	704	3.13	744	3.46	784	3.80	822	4.15	859	4.51	896	4.89	933	5.28
7125	596	2.50	640	2.83	683	3.17	724	3.52	763	3.86	801	4.22	838	4.58	874	4.95	909	5.33	944	5.73
7500	622	2.87	663	3.22	705	3.58	744	3.93	782	4.30	818	4.66	854	5.04	889	5.42	923	5.81	—	—

- Standard static 507-676 RPM, 2.9 Max BHP
- Medium static 627-851 RPM, 3.7 Max BHP
- High static 776-955 RPM, 6.1 Max BHP
- BOLD** — Indicated field-supplied drive.

558J*16 VERTICAL UNIT — 15 TON
(For more information, see General Fan Performance Notes on page 49.)

CFM	Available External Static Pressure (in. wg)																			
	0.2		0.4		0.6		0.8		1.0		1.2		1.4		1.6		1.8		2.0	
	RPM	BHP	RPM	BHP	RPM	BHP	RPM	BHP	RPM	BHP	RPM	BHP	RPM	BHP	RPM	BHP	RPM	BHP	RPM	BHP
4500	425	0.76	490	1.02	550	1.30	607	1.61	664	1.96	719	2.34	772	2.76	823	3.20	872	3.67	918	4.16
4875	448	0.92	510	1.20	566	1.49	621	1.81	674	2.15	725	2.54	776	2.95	825	3.40	873	3.87	919	4.37
5250	472	1.10	531	1.40	584	1.70	636	2.03	686	2.38	734	2.76	783	3.18	830	3.63	876	4.10	920	4.60
5625	496	1.30	552	1.62	603	1.94	652	2.28	699	2.64	746	3.03	791	3.44	836	3.89	880	4.36	923	4.86
6000	520	1.52	574	1.86	623	2.20	670	2.55	715	2.92	759	3.32	802	3.74	845	4.18	887	4.66	928	5.16
6375	544	1.77	596	2.13	644	2.49	688	2.86	731	3.24	773	3.64	814	4.07	855	4.52	895	4.99	935	5.49
6750	568	2.05	618	2.43	664	2.81	707	3.19	749	3.59	789	4.00	828	4.43	867	4.89	905	5.36	943	5.87
7125	593	2.35	641	2.75	685	3.16	727	3.56	767	3.97	806	4.39	844	4.84	881	5.29	917	5.78	—	—
7500	617	2.69	664	3.11	707	3.53	747	3.95	786	4.38	823	4.82	860	5.27	895	5.74	—	—	—	—

- Standard static 507-676 RPM, 2.9 Max BHP
- Medium static 627-851 RPM, 3.7 Max BHP
- High static 776-955 RPM, 6.1 Max BHP
- BOLD** — Indicated field-supplied drive.

ELECTRICAL DATA

LEGEND AND NOTES

Applicable for Electrical Data Tables on pages 55-92

LEGEND

BRKR	— Circuit breaker
C.O.	— Convenience outlet
DISC	— Disconnect
EFF	— Efficiency
FLA	— Full load amps
LRA	— Locked rotor amps
MCA	— Minimum circuit amps
MOCP	— MAX FUSE or HACR Breaker
P.E.	— Power exhaust
Pwr'd fr/unit	— Powered from unit
PWRD C.O.	— Powered convenience outlet
RLA	— Rated load amps
UNPWR C.O.	— Unpowered convenience outlet

NOTES

- In compliance with NEC requirements for multi-motor and combination load equipment (refer to NEC Articles 430 and 440), the overcurrent protective device for the unit shall be fuse or HACR breaker. Canadian units may be fuse or circuit breaker.
- Unbalanced 3-Phase Supply Voltage
Never operate a motor where a phase imbalance in supply voltage is greater than 2%. Use the following formula to determine the percentage of voltage imbalance.

$$\% \text{ Voltage Imbalance} = 100 \times \frac{\text{max voltage deviation from average voltage}}{\text{average voltage}}$$

Example: Supply voltage is 230-3-60

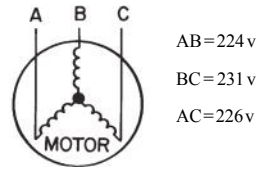

$$\begin{aligned} \text{Average Voltage} &= \frac{(224 + 231 + 226)}{3} = \frac{681}{3} \\ &= 227 \end{aligned}$$

Determine maximum deviation from average voltage.

$$(AB) 227 - 224 = 3 \text{ v}$$

$$(BC) 231 - 227 = 4 \text{ v}$$

$$(AC) 227 - 226 = 1 \text{ v}$$

Maximum deviation is 4 v.

Determine percent of voltage imbalance.

$$\% \text{ Voltage Imbalance} = 100 \times \frac{4}{227}$$

$$= 1.76\%$$

This amount of phase imbalance is satisfactory as it is below the maximum allowable 2%.

IMPORTANT: If the supply voltage phase imbalance is more than 2%, contact your local electric utility company immediately.

SINGLE SPEED INDOOR FAN MOTOR, 6-15 TONS

UNIT SIZE	V-Ph-Hz	VOLTAGE RANGE		COMP 1		COMP 2		OFM (ea)		IFM		
		Min	Max	RLA	LRA	RLA	LRA	Watts	FLA	TYPE	EFF at Full Load	FLA
558J-07A/G (1-Circuit/ 1-Stage Cooling)	208-3-60	187	253	19.6	136	—	—	325	1.5	STD	69%	5.2
								325	1.5	MED	89%	8.4
								325	1.5	HIGH	87%	10.6
	230-3-60	187	253	19.6	136	—	—	325	1.5	STD	69%	5.2
								325	1.5	MED	89%	8.3
								325	1.5	HIGH	87%	10.6
	460-3-60	414	506	8.2	66	—	—	325	0.8	STD	69%	2.6
								325	0.8	MED	89%	4.2
								325	0.8	HIGH	87%	5.3
	575-3-60	518	633	6.6	55	—	—	325	0.6	STD	78%	2.0
								325	0.6	MED	77%	2.8
								325	0.6	HIGH	77%	2.8
558J-08D/K (2-Circuit/ 2-Stage Cooling)	208-3-60	187	253	13.6	83	13.6	83	325	1.5	STD	87%	5.2
								325	1.5	MED	89%	8.4
								325	1.5	HIGH	83%	13.6
	230-3-60	187	253	13.6	83	13.6	83	325	1.5	STD	87%	4.9
								325	1.5	MED	89%	8.3
								325	1.5	HIGH	83%	12.7
	460-3-60	414	506	6.1	41	6.1	41	325	0.8	STD	87%	2.5
								325	0.8	MED	89%	4.2
								325	0.8	HIGH	83%	6.4
	575-3-60	518	633	4.2	33	4.2	33	325	0.6	STD	87%	2.8
								325	0.6	MED	77%	2.8
								325	0.6	HIGH	81%	5.6
558J-08N (1-Circuit/ 2-Stage Cooling)	208-3-60	187	253	28.8	164	—	—	325	1.5	STD	87%	5.2
								325	1.5	MED	89%	8.4
								325	1.5	HIGH	83%	13.6
	230-3-60	187	253	26.8	164	—	—	325	1.5	STD	87%	4.9
								325	1.5	MED	89%	8.3
								325	1.5	HIGH	83%	12.7
	460-3-60	414	506	12.0	94	—	—	325	0.8	STD	87%	2.5
								325	0.8	MED	89%	4.2
								325	0.8	HIGH	83%	6.4
558J-09D/K (2-Circuit/ 2-Stage Cooling)	208-3-60	187	253	14.5	98	13.7	83	325	1.5	STD	75%	5.2
								325	1.5	MED	87%	6.9
								325	1.5	HIGH	87%	10.6
	230-3-60	187	253	14.5	98	13.7	83	325	1.5	STD	75%	5.2
								325	1.5	MED	87%	6.7
								325	1.5	HIGH	87%	10.6
	460-3-60	414	506	6.3	55	6.2	41	325	0.8	STD	75%	2.6
								325	0.8	MED	87%	3.4
								325	0.8	HIGH	87%	5.3
575-3-60	518	633	6.0	41	4.8	33	325	0.6	STD	72%	1.6	
							325	0.6	MED	78%	2.0	
							325	0.6	HIGH	77%	2.8	
558J-09N (1-Circuit/ 2-Stage Cooling)	208-3-60	187	253	28.8	223	—	—	325	1.5	STD	75%	5.2
								325	1.5	MED	87%	6.9
								325	1.5	HIGH	87%	10.6
	230-3-60	187	253	28.8	223	—	—	325	1.5	STD	75%	5.2
								325	1.5	MED	87%	6.7
								325	1.5	HIGH	87%	10.6
	460-3-60	414	506	12.5	100	—	—	325	0.8	STD	75%	2.6
								325	0.8	MED	87%	3.4
								325	0.8	HIGH	87%	5.3
	575-3-60	518	633	9.7	70	—	—	325	0.6	STD	72%	1.6
								325	0.6	MED	78%	2.0
								325	0.6	HIGH	77%	2.8

See: Legend and Notes on page 54.

ELECTRICAL DATA (CONT)

SINGLE SPEED INDOOR FAN MOTOR, 6-15 TONS (cont)

UNIT SIZE	V-Ph-Hz	VOLTAGE RANGE		COMP 1		COMP 2		OFM (ea)		IFM		
		Min	Max	RLA	LRA	RLA	LRA	Watts	FLA	TYPE	EFF at Full Load	FLA
558J-12D/K (2-Circuit/ 2-Stage Cooling)	208-3-60	187	253	15.6	110	15.9	110	325	1.5	STD	69%	5.2
								325	1.5	MED	87%	10.6
								325	1.5	HIGH	83%	13.6
	230-3-60	187	253	15.6	110	15.9	110	325	1.5	STD	69%	5.2
								325	1.5	MED	87%	10.6
								325	1.5	HIGH	83%	12.7
	460-3-60	414	506	7.7	52	7.7	52	325	0.8	STD	69%	2.6
								325	0.8	MED	87%	5.3
								325	0.8	HIGH	83%	6.4
	575-3-60	518	633	5.8	39	5.7	39	325	0.6	STD	78%	2.0
								325	0.6	MED	77%	2.8
								325	0.6	HIGH	81%	5.6
558J-12N (1-Circuit/ 2-Stage Cooling)	208-3-60	187	253	32.5	240	—	—	325	1.5	STD	69%	5.2
								325	1.5	MED	87%	10.6
								325	1.5	HIGH	83%	13.6
	230-3-60	187	253	32.5	240	—	—	325	1.5	STD	69%	5.2
								325	1.5	MED	87%	10.6
								325	1.5	HIGH	83%	12.7
	460-3-60	414	506	14.8	130	—	—	325	0.8	STD	69%	2.6
								325	0.8	MED	87%	5.3
								325	0.8	HIGH	83%	6.4
	575-3-60	518	633	11.1	94	—	—	325	0.6	STD	78%	2.0
								325	0.6	MED	77%	2.8
								325	0.6	HIGH	81%	5.6
558J-14D/K (2-Circuit/ 2-Stage Cooling)	208-3-60	187	253	19.6	136	22.4	149	1070	6.2	STD	89%	8.4
								1070	6.2	MED	87%	10.6
								1070	6.2	HIGH	83%	13.6
	230-3-60	187	253	19.6	136	22.4	149	1070	6.2	STD	89%	8.3
								1070	6.2	MED	87%	10.6
								1070	6.2	HIGH	83%	12.7
	460-3-60	414	506	8.2	66	10.6	75	1070	3.1	STD	89%	4.2
								1070	3.1	MED	87%	5.3
								1070	3.1	HIGH	83%	6.4
	575-3-60	518	633	6.6	55	7.7	54	1070	2.5	STD	77%	2.8
								1070	2.5	MED	77%	2.8
								1070	2.5	HIGH	81%	5.6
558J-16D/K (2-Circuit/ 2-Stage Cooling)	208-3-60	187	253	25.0	164	25.0	164	280	1.5	STD	89%	8.4
								280	1.5	MED	87%	10.6
								280	1.5	HIGH	87%	17.0
								280	1.5	HIGH EFF	90%	20.4
	230-3-60	187	253	25.0	164	25.0	164	280	1.5	STD	89%	8.3
								280	1.5	MED	87%	10.6
								280	1.5	HIGH	87%	15.0
								280	1.5	HIGH EFF	90%	20.4
	460-3-60	414	506	12.2	100	12.8	100	280	0.8	STD	89%	4.2
								280	0.8	MED	87%	5.3
								280	0.8	HIGH	87%	7.6
								280	0.8	HIGH EFF	90%	10.2
575-3-60	518	633	9.8	78	9.6	78	280	0.6	STD	77%	2.8	
							280	0.6	MED	77%	2.8	
							280	0.6	HIGH	90%	6.1	
							280	0.6	HIGH EFF	94%	9.0	

See Legend and Notes on page 54.

1-STAGE COOLING WITH TWO-SPEED INDOOR FAN MOTOR, 6 TONS

UNIT SIZE	V-Ph-Hz	VOLTAGE RANGE		COMP 1		COMP 2		OFM (ea)		IFM		
		Min	Max	RLA	LRA	RLA	LRA	Watts	FLA	TYPE	EFF at Full Load	FLA
558J-07A/G (1-Circuit/ 1-Stage Cooling)	208-3-60	187	253	19.6	136	—	—	325	1.5	STD	0.77	7.1
								325	1.5	MED	0.85	8.6
								325	1.5	HIGH	0.82	10.8
	230-3-60	187	253	19.6	136	—	—	325	1.5	STD	0.77	6.8
								325	1.5	MED	0.85	7.8
								325	1.5	HIGH	0.82	9.8
	460-3-60	414	506	8.2	66	—	—	325	0.8	STD	0.77	3.4
								325	0.8	MED	0.85	3.8
								325	0.8	HIGH	0.82	4.9
	575-3-60	518	633	6.6	55	—	—	325	0.6	STD	0.80	3.5
								325	0.6	MED	0.84	4.5
								325	0.6	HIGH	0.84	4.5

TWO-SPEED INDOOR FAN MOTOR, 7.5-15 TONS

UNIT SIZE	V-Ph-Hz	VOLTAGE RANGE		COMP 1		COMP 2		OFM (ea)		IFM		
		Min	Max	RLA	LRA	RLA	LRA	Watts	FLA	TYPE	EFF at Full Load	FLA
558J-08D/K (2-Circuit/ 2-Stage Cooling)	208-3-60	187	253	13.6	83	13.6	83	325	1.5	STD	0.84	5.8
								325	1.5	MED	0.85	8.6
								325	1.5	HIGH	0.84	13.6
	230-3-60	187	253	13.6	83	13.6	83	325	1.5	STD	0.84	5.6
								325	1.5	MED	0.85	7.8
								325	1.5	HIGH	0.84	12.7
	460-3-60	414	506	6.1	41	6.1	41	325	0.8	STD	0.79	2.9
								325	0.8	MED	0.85	3.8
								325	0.8	HIGH	0.84	6.4
	575-3-60	518	633	4.2	33	4.2	33	325	0.6	STD	0.81	2.8
								325	0.6	MED	0.84	4.5
								325	0.6	HIGH	0.83	6.2
558J-09D/K (2-Circuit/ 2-Stage Cooling)	208-3-60	187	253	14.5	98	13.7	83	325	1.5	STD	0.84	5.8
								325	1.5	MED	0.77	7.1
								325	1.5	HIGH	0.82	10.8
	230-3-60	187	253	14.5	98	13.7	83	325	1.5	STD	0.84	5.6
								325	1.5	MED	0.77	6.8
								325	1.5	HIGH	0.82	9.8
	460-3-60	414	506	6.3	55	6.2	41	325	0.8	STD	0.79	2.9
								325	0.8	MED	0.77	3.4
								325	0.8	HIGH	0.82	4.9
	575-3-60	518	633	6.0	41	4.8	33	325	0.6	STD	0.81	2.8
								325	0.6	MED	0.80	3.5
								325	0.6	HIGH	0.84	4.5
558J-12D/K (2-Circuit/ 2-Stage Cooling)	208-3-60	187	253	15.6	110	15.9	110	325	1.5	STD	0.77	7.1
								325	1.5	MED	0.82	10.8
								325	1.5	HIGH	0.84	13.6
	230-3-60	187	253	15.6	110	15.9	110	325	1.5	STD	0.77	6.8
								325	1.5	MED	0.82	9.8
								325	1.5	HIGH	0.84	12.7
	460-3-60	414	506	7.7	52	7.7	52	325	0.8	STD	0.77	3.4
								325	0.8	MED	0.82	4.9
								325	0.8	HIGH	0.84	6.4
	575-3-60	518	633	5.8	39	5.7	39	325	0.6	STD	0.80	3.5
								325	0.6	MED	0.84	4.5
								325	0.6	HIGH	0.83	6.2

See Legend and Notes on page 54.

ELECTRICAL DATA (CONT)

TWO-SPEED INDOOR FAN MOTOR, 7.5-15 TONS (cont)

UNIT SIZE	V-Ph-Hz	VOLTAGE RANGE		COMP 1		COMP 2		OFM (ea)		IFM		
		Min	Max	RLA	LRA	RLA	LRA	Watts	FLA	TYPE	EFF at Full Load	FLA
558J-14D/K (2-Circuit/ 2-Stage Cooling)	208-3-60	187	253	19.6	136	22.4	149	1070	6.2	STD	0.85	8.6
								1070	6.2	MED	0.82	10.8
								1070	6.2	HIGH	0.84	13.6
	230-3-60	187	253	19.6	136	22.4	149	1070	6.2	STD	0.85	7.8
								1070	6.2	MED	0.82	9.8
								1070	6.2	HIGH	0.84	12.7
	460-3-60	414	506	8.2	66	10.6	75	1070	3.1	STD	0.85	3.8
								1070	3.1	MED	0.82	4.9
								1070	3.1	HIGH	0.84	6.4
	575-3-60	518	633	6.6	55	7.7	54	1070	2.5	STD	0.84	4.5
								1070	2.5	MED	0.84	4.5
								1070	2.5	HIGH	0.83	6.2
558J-16D/K (2-Circuit/ 2-Stage Cooling)	208-3-60	187	253	25.0	164	25.0	164	280	1.5	STD	0.85	8.6
								280	1.5	MED	0.82	10.8
								280	1.5	HIGH	0.90	20.4
	230-3-60	187	253	25.0	164	25.0	164	280	1.5	STD	0.85	7.8
								280	1.5	MED	0.82	9.8
								280	1.5	HIGH	0.90	20.4
	460-3-60	414	506	12.2	100	12.8	100	280	0.8	STD	0.85	3.8
								280	0.8	MED	0.82	4.9
								280	0.8	HIGH	0.90	10.2
	575-3-60	518	633	9.8	78	9.6	78	280	0.6	STD	0.84	4.5
								280	0.6	MED	0.84	4.5
								280	0.6	HIGH	0.94	9.0

See Legend and Notes on page 54.

**SINGLE SPEED INDOOR FAN MOTOR
WITHOUT FACTORY INSTALLED NON-FUSED DISCONNECT**

UNIT SIZE	NOM. V-PH-HZ	IFM TYPE	ELECTRIC HEATER PART NUMBER CRHEATERXXXXXX	NOM PWR (kW)	APP PWR (kW)	SINGLE POINT KIT PART NUMBER CRSINGLEXXXA00			
						NO C.O. or Unpowered C.O.		w/PWRD C.O.	
						NO P.E.	w/ P.E. (pwrd fr/unit)	NO P.E.	w/ P.E. (pwrd fr/unit)
558J-07A (1-Circuit / 1-Stage Cooling)	208/230-3-60	STD	102A00	6.5	4.9/6.0	—	—	—	—
			104B00	10.5	7.9/9.6	—	—	—	—
			105A00	16.0	12.0/14.7	037	037	038	038
			104B00,104B00	21.0	15.8/19.3	038	038	038	038
		104B00,105A00	26.5	19.9/24.3	038	038	038	038	
		MED	102A00	6.5	4.9/6.0	—	—	—	—
			104B00	10.5	7.9/9.6	—	—	—	—
			105A00	16.0	12.0/14.7	037	038	038	038
			104B00,104B00	21.0	15.8/19.3	038	038	038	038
		104B00,105A00	26.5	19.9/24.3	038	038	038	038	
		HIGH	102A00	6.5	4.9/6.0	—	—	—	—
			104B00	10.5	7.9/9.6	—	—	—	037
	105A00		16.0	12.0/14.7	038	038	038	038	
	104B00,104B00		21.0	15.8/19.3	038	038	038	038	
	104B00,105A00	26.5	19.9/24.3	038	038	038	038		
	460-3-60	STD	106A00	6.0	5.5	—	—	—	—
			108A00	11.5	10.6	—	—	—	—
			109A00	14.0	12.9	—	—	—	—
			108A00,108A00	23.0	21.1	037	037	037	037
			108A00,109A00	25.5	23.4	037	037	037	037
		MED	106A00	6.0	5.5	—	—	—	—
			108A00	11.5	10.6	—	—	—	—
			109A00	14.0	12.9	—	—	—	—
			108A00,108A00	23.0	21.1	037	037	037	037
		108A00,109A00	25.5	23.4	037	037	037	037	
		HIGH	106A00	6.0	5.5	—	—	—	—
			108A00	11.5	10.6	—	—	—	—
			109A00	14.0	12.9	—	—	—	—
108A00,108A00			23.0	21.1	037	037	037	037	
108A00,109A00			25.5	23.4	037	037	037	037	

LEGEND

- APP PWR — 208 / 230V / 460V / 575V
- C.O. — Convenience outlet
- FLA — Full load amps
- IFM — Indoor fan motor
- NOM PWR — 240V / 480V / 600V
- P.E. — Power exhaust
- PWRD — Powered convenience outlet
- UNPWRD — Unpowered convenience outlet

ELECTRICAL DATA (CONT)

SINGLE SPEED INDOOR FAN MOTOR WITH FACTORY INSTALLED NON-FUSED DISCONNECT

UNIT SIZE	NOM. V-PH-HZ	IFM TYPE	ELECTRIC HEATER PART NUMBER CRHEATERXXXXXX	NOM PWR (kW)	APP PWR (kW)	SINGLE POINT KIT PART NUMBER CRSINGLEXXXA00			
						NO C.O. or Unpowered C.O.		w/PWRD C.O.	
						NO P.E.	w/ P.E. (pwrd fr/unit)	NO P.E.	w/ P.E. (pwrd fr/unit)
558J-07A (1-Circuit / 1-Stage Cooling)	208/230-3-60	STD	102A00	6.5	4.9/6.0	037	037	037	037
			104B00	10.5	7.9/9.6	037	037	037	037
			105A00	16.0	12.0/14.7	037	037	038	038
			104B00,104B00	21.0	15.8/19.3	038	038	038	038
			104B00,105A00	26.5	19.9/24.3	038	038	038	038
		MED	102A00	6.5	4.9/6.0	037	037	037	037
			104B00	10.5	7.9/9.6	037	037	037	037
			105A00	16.0	12.0/14.7	037	038	038	038
			104B00,104B00	21.0	15.8/19.3	038	038	038	038
			104B00,105A00	26.5	19.9/24.3	038	038	038	038
		HIGH	102A00	6.5	4.9/6.0	037	037	037	037
			104B00	10.5	7.9/9.6	037	037	037	037
	105A00		16.0	12.0/14.7	038	038	038	038	
	104B00,104B00		21.0	15.8/19.3	038	038	038	038	
	104B00,105A00		26.5	19.9/24.3	038	038	038	038	
	460-3-60	STD	106A00	6.0	5.5	—	—	—	—
			108A00	11.5	10.6	—	—	—	—
			109A00	14.0	12.9	—	—	—	—
			108A00,108A00	23.0	21.1	037	037	037	037
			108A00,109A00	25.5	23.4	037	037	037	037
		MED	106A00	6.0	5.5	—	—	—	—
			108A00	11.5	10.6	—	—	—	—
			109A00	14.0	12.9	—	—	—	—
			108A00,108A00	23.0	21.1	037	037	037	037
108A00,109A00			25.5	23.4	037	037	037	037	
HIGH		106A00	6.0	5.5	—	—	—	—	
		108A00	11.5	10.6	—	—	—	—	
	109A00	14.0	12.9	—	—	—	—		
	108A00,108A00	23.0	21.1	037	037	037	037		
	108A00,109A00	25.5	23.4	037	037	037	037		

LEGEND

APP PWR — 208 / 230V / 460V / 575V
C.O. — Convenience outlet
FLA — Full load amps
IFM — Indoor fan motor
NOM PWR — 240V / 480V / 600V
P.E. — Power exhaust
PWRD — Powered convenience outlet
UNPWRD — Unpowered convenience outlet

**TWO SPEED INDOOR FAN MOTOR
WITH OR WITHOUT FACTORY INSTALLED NON-FUSED DISCONNECT**

UNIT SIZE	NOM. V-PH-HZ	IFM TYPE	ELECTRIC HEATER PART NUMBER CRHEATERXXXXXX	NOM PWR (kW)	APP PWR (kW)	SINGLE POINT KIT PART NUMBER CRSINGLEXXXXA00			
						NO C.O. or Unpowered C.O.		w/PWRD C.O.	
						NO P.E.	w/ P.E. (pwrd fr/unit)	NO P.E.	w/ P.E. (pwrd fr/unit)
558J-07A (1-Circuit / 1-Stage Cooling)	208/230-3-60	STD	102A00	6.5	4.9/6.0	—	—	—	—
			104B00	10.5	7.9/9.6	—	—	—	—
			105A00	16.0	12.0/14.7	037	037	038	038
			104B00,104B00	21.0	15.8/19.3	038	038	038	038
			104B00,105A00	26.5	19.9/24.3	038	038	038	038
		MED	102A00	6.5	4.9/6.0	—	—	—	—
			104B00	10.5	7.9/9.6	—	—	—	—
			105A00	16.0	12.0/14.7	037	038	038	038
			104B00,104B00	21.0	15.8/19.3	038	038	038	038
		HIGH	104B00,105A00	26.5	19.9/24.3	038	038	038	038
			102A00	6.5	4.9/6.0	—	—	—	—
			104B00	10.5	7.9/9.6	—	—	—	037
	105A00		16.0	12.0/14.7	038	038	038	038	
	104B00,104B00		21.0	15.8/19.3	038	038	038	038	
	460-3-60	STD	104B00,105A00	26.5	19.9/24.3	038	038	038	038
			106A00	6.0	5.5	—	—	—	—
			108A00	11.5	10.6	—	—	—	—
			109A00	14.0	12.9	—	—	—	—
			108A00,108A00	23.0	21.1	037	037	037	037
		MED	108A00,109A00	25.5	23.4	037	037	037	037
			106A00	6.0	5.5	—	—	—	—
			108A00	11.5	10.6	—	—	—	—
			109A00	14.0	12.9	—	—	—	—
		HIGH	108A00,108A00	23.0	21.1	037	037	037	037
108A00,109A00			25.5	23.4	037	037	037	037	
106A00			6.0	5.5	—	—	—	—	
108A00	11.5		10.6	—	—	—	—		
109A00	14.0		12.9	—	—	—	—		
			108A00,108A00	23.0	21.1	037	037	037	037
			108A00,109A00	25.5	23.4	037	037	037	037

LEGEND

- APP PWR — 208 / 230V / 460V / 575V
- C.O. — Convenience outlet
- FLA — Full load amps
- IFM — Indoor fan motor
- NOM PWR — 240V / 480V / 600V
- P.E. — Power exhaust
- PWRD — Powered convenience outlet
- UNPWRD — Unpowered convenience outlet

ELECTRICAL DATA (CONT)

SINGLE SPEED INDOOR FAN MOTOR WITHOUT FACTORY INSTALLED NON-FUSED DISCONNECT

UNIT SIZE	NOM. V-PH-HZ	IFM TYPE	ELECTRIC HEATER PART NUMBER CRHEATERXXXXXX	NOM PWR (kW)	APP PWR (kW)	SINGLE POINT KIT PART NUMBER CRSINGLEXXXXA00			
						NO C.O. or Unpowered C.O.		w/PWRD C.O.	
						NO P.E.	w/ P.E. (pwrd fr/unit)	NO P.E.	w/ P.E. (pwrd fr/unit)
558J-08D (2-Circuit / 2-Stage Cooling)	208/230-3-60	STD	117A00	10.4	7.8/9.6	042	042	042	042
			110A00	16.0	12.0/14.7	042	042	043	043
			111A00	24.8	18.6/22.8	043	043	043	043
			112A00	32.0	24.0/29.4	043	043	043	043
			112A00,117A00	42.4	31.8/38.9	045	045	045	045
		MED	117A00	10.4	7.8/9.6	042	042	042	042
			110A00	16.0	12.0/14.7	042	043	043	043
			111A00	24.8	18.6/22.8	043	043	043	043
			112A00	32.0	24.0/29.4	043	043	043	043
			112A00,117A00	42.4	31.8/38.9	045	045	045	045
		HIGH	117A00	10.4	7.8/9.6	042	042	042	043
			110A00	16.0	12.0/14.7	043	043	043	043
			111A00	24.8	18.6/22.8	043	043	043	043
			112A00	32.0	24.0/29.4	043	043	043	043
			112A00,117A00	42.4	31.8/38.9	045	045	045	045
	460-3-60	STD	116B00	13.9	12.8	042	042	042	042
			113B00	16.5	15.2	042	042	042	042
			114B00	27.8	25.5	042	042	042	042
			115B00	33.0	30.3	042	042	042	042
			128B00	41.7	38.3	044	044	044	044
		MED	116B00	13.9	12.8	042	042	042	042
			113B00	16.5	15.2	042	042	042	042
			114B00	27.8	25.5	042	042	042	042
			115B00	33.0	30.3	042	042	042	042
			128B00	41.7	38.3	044	044	044	044
		HIGH	116B00	13.9	12.8	042	042	042	042
			113B00	16.5	15.2	042	042	042	042
			114B00	27.8	25.5	042	042	042	042
			115B00	33.0	30.3	042	042	044	044
			128B00	41.7	38.3	044	044	044	044
575-3-60	STD	118A00	18.0	16.5	042	042	042	042	
		119A00	36.0	33.1	042	042	042	042	
	MED	118A00	18.0	16.5	042	042	042	042	
		119A00	36.0	33.1	042	042	042	042	
	HIGH	118A00	18.0	16.5	042	042	042	042	
		119A00	36.0	33.1	042	042	042	042	

LEGEND

- APP PWR — 208 / 230V / 460V / 575V
- C.O. — Convenience outlet
- FLA — Full load amps
- IFM — Indoor fan motor
- NOM PWR — 240V / 480V / 600V
- P.E. — Power exhaust
- PWRD — Powered convenience outlet
- UNPWRD — Unpowered convenience outlet

**SINGLE SPEED INDOOR FAN MOTOR
WITHOUT FACTORY INSTALLED NON-FUSED DISCONNECT (cont)**

UNIT SIZE	NOM. V-PH-HZ	IFM TYPE	ELECTRIC HEATER PART NUMBER CRHEATERXXXXXX	NOM PWR (kW)	APP PWR (kW)	SINGLE POINT KIT PART NUMBER CRSINGLEXXXA00			
						NO C.O. or Unpowered C.O.		w/PWRD C.O.	
						NO P.E.	w/ P.E. (pwrd fr/unit)	NO P.E.	w/ P.E. (pwrd fr/unit)
558J-08N (1-Circuit / 2-Stage Cooling)	208/230-3-60	STD	117A00	10.4	7.8/9.6	042	042	042	042
			110A00	16.0	12.0/14.7	042	042	043	043
			111A00	24.8	18.6/22.8	043	043	043	043
			112A00	32.0	24.0/29.4	043	043	043	043
			112A00,117A00	42.4	31.8/38.9	045	045	045	045
		MED	117A00	10.4	7.8/9.6	042	042	042	043
			110A00	16.0	12.0/14.7	042	043	043	043
			111A00	24.8	18.6/22.8	043	043	043	043
			112A00	32.0	24.0/29.4	043	043	043	043
			112A00,117A00	42.4	31.8/38.9	045	045	045	045
		HIGH	117A00	10.4	7.8/9.6	042	043	043	043
			110A00	16.0	12.0/14.7	043	043	043	043
	111A00		24.8	18.6/22.8	043	043	043	043	
	112A00		32.0	24.0/29.4	043	043	043	043	
	112A00,117A00		42.4	31.8/38.9	045	045	045	045	
	460-3-60	STD	116B00	13.9	12.8	042	042	042	042
			113B00	16.5	15.2	042	042	042	042
			114B00	27.8	25.5	042	042	042	042
			115B00	33.0	30.3	042	042	042	042
			128B00	41.7	38.3	044	044	044	044
		MED	116B00	13.9	12.8	042	042	042	042
			113B00	16.5	15.2	042	042	042	042
			114B00	27.8	25.5	042	042	042	042
			115B00	33.0	30.3	042	042	042	042
HIGH		128B00	41.7	38.3	044	044	044	044	
		116B00	13.9	12.8	042	042	042	042	
		113B00	16.5	15.2	042	042	042	042	
			114B00	27.8	25.5	042	042	042	042
			115B00	33.0	30.3	042	042	044	044
			128B00	41.7	38.3	044	044	044	044

LEGEND

- APP PWR — 208 / 230V / 460V / 575V
- C.O. — Convenience outlet
- FLA — Full load amps
- IFM — Indoor fan motor
- NOM PWR — 240V / 480V / 600V
- P.E. — Power exhaust
- PWRD — Powered convenience outlet
- UNPWRD — Unpowered convenience outlet

ELECTRICAL DATA (CONT)

SINGLE SPEED INDOOR FAN MOTOR WITH FACTORY INSTALLED NON-FUSED DISCONNECT

UNIT SIZE	NOM. V-PH-HZ	IFM TYPE	ELECTRIC HEATER PART NUMBER CRHEATERXXXXXX	NOM PWR (kW)	APP PWR (kW)	SINGLE POINT KIT PART NUMBER CRSINGLEXXXXA00			
						NO C.O. or Unpowered C.O.		w/PWRD C.O.	
						NO P.E.	w/ P.E. (pwrd fr/unit)	NO P.E.	w/ P.E. (pwrd fr/unit)
558J-08D (2-Circuit / 2-Stage Cooling)	208/230-3-60	STD	117A00	10.4	7.8/9.6	042	042	042	042
			110A00	16.0	12.0/14.7	042	042	043	043
			111A00	24.8	18.6/22.8	043	043	043	043
			112A00	32.0	24.0/29.4	043	043	043	043
			112A00,117A00	42.4	31.8/38.9	045	045	045	045
		MED	117A00	10.4	7.8/9.6	042	042	042	042
			110A00	16.0	12.0/14.7	042	043	043	043
			111A00	24.8	18.6/22.8	043	043	043	043
			112A00	32.0	24.0/29.4	043	043	043	043
			112A00,117A00	42.4	31.8/38.9	045	045	045	045
		HIGH	117A00	10.4	7.8/9.6	042	042	042	043
			110A00	16.0	12.0/14.7	043	043	043	043
	111A00		24.8	18.6/22.8	043	043	043	043	
	112A00		32.0	24.0/29.4	043	043	043	043	
	112A00,117A00		42.4	31.8/38.9	045	045	045	045	
	460-3-60	STD	116B00	13.9	12.8	042	042	042	042
			113B00	16.5	15.2	042	042	042	042
			114B00	27.8	25.5	042	042	042	042
			115B00	33.0	30.3	042	042	042	042
			128B00	41.7	38.3	044	044	044	044
		MED	116B00	13.9	12.8	042	042	042	042
			113B00	16.5	15.2	042	042	042	042
			114B00	27.8	25.5	042	042	042	042
			115B00	33.0	30.3	042	042	042	042
			128B00	41.7	38.3	044	044	044	044
		HIGH	116B00	13.9	12.8	042	042	042	042
			113B00	16.5	15.2	042	042	042	042
	114B00		27.8	25.5	042	042	042	042	
	115B00		33.0	30.3	042	042	044	044	
	128B00		41.7	38.3	044	044	044	044	
	575-3-60	STD	118A00	18.0	16.5	042	042	042	042
			119A00	36.0	33.1	042	042	042	042
		MED	118A00	18.0	16.5	042	042	042	042
			119A00	36.0	33.1	042	042	042	042
		HIGH	118A00	18.0	16.5	042	042	042	042
			119A00	36.0	33.1	042	042	042	042

LEGEND

- APP PWR — 208 / 230V / 460V / 575V
- C.O. — Convenience outlet
- FLA — Full load amps
- IFM — Indoor fan motor
- NOM PWR — 240V / 480V / 600V
- P.E. — Power exhaust
- PWRD — Powered convenience outlet
- UNPWRD — Unpowered convenience outlet

**SINGLE SPEED INDOOR FAN MOTOR
WITH FACTORY INSTALLED NON-FUSED DISCONNECT (cont)**

UNIT SIZE	NOM. V-PH-HZ	IFM TYPE	ELECTRIC HEATER PART NUMBER CRHEATERXXXXXX	NOM PWR (kW)	APP PWR (kW)	SINGLE POINT KIT PART NUMBER CRSINGLEXXA00			
						NO C.O. or Unpowered C.O.		w/PWRD C.O.	
						NO P.E.	w/ P.E. (pwrd fr/unit)	NO P.E.	w/ P.E. (pwrd fr/unit)
558J-08N (1-Circuit / 2-Stage Cooling)	208/230-3-60	STD	117A00	10.4	7.8/9.6	047	047	047	049
			110A00	16.0	12.0/14.7	047	047	049	049
			111A00	24.8	18.6/22.8	049	049	049	049
			112A00	32.0	24.0/29.4	049	049	049	049
			112A00,117A00	42.4	31.8/38.9	051	051	051	051
		MED	117A00	10.4	7.8/9.6	047	047	047	049
			110A00	16.0	12.0/14.7	047	049	049	049
			111A00	24.8	18.6/22.8	049	049	049	049
			112A00	32.0	24.0/29.4	049	049	049	049
			112A00,117A00	42.4	31.8/38.9	051	051	051	051
		HIGH	117A00	10.4	7.8/9.6	047	049	049	049
			110A00	16.0	12.0/14.7	049	049	049	049
			111A00	24.8	18.6/22.8	049	049	049	049
			112A00	32.0	24.0/29.4	049	049	049	049
			112A00,117A00	42.4	31.8/38.9	051	051	051	051
	460-3-60	STD	116B00	13.9	12.8	047	047	047	047
			113B00	16.5	15.2	047	047	047	047
			114B00	27.8	25.5	047	047	047	047
			115B00	33.0	30.3	047	047	047	047
			128B00	41.7	38.3	050	050	050	050
		MED	116B00	13.9	12.8	047	047	047	047
			113B00	16.5	15.2	047	047	047	047
			114B00	27.8	25.5	047	047	047	047
			115B00	33.0	30.3	047	047	047	050
		HIGH	128B00	41.7	38.3	050	050	050	050
			116B00	13.9	12.8	047	047	047	047
			113B00	16.5	15.2	047	047	047	047
			114B00	27.8	25.5	047	047	047	047
			115B00	33.0	30.3	047	047	047	050
			128B00	41.7	38.3	050	050	050	050

LEGEND

- APP PWR — 208 / 230V / 460V / 575V
- C.O. — Convenience outlet
- FLA — Full load amps
- IFM — Indoor fan motor
- NOM PWR — 240V / 480V / 600V
- P.E. — Power exhaust
- PWRD — Powered convenience outlet
- UNPWRD — Unpowered convenience outlet

ELECTRICAL DATA (CONT)

2-SPEED INDOOR FAN MOTOR WITH OR WITHOUT FACTORY INSTALLED NON-FUSED DISCONNECT

UNIT SIZE	NOM. V-PH-HZ	IFM TYPE	ELECTRIC HEATER PART NUMBER CRHEATERXXXXXX	NOM PWR (kW)	APP PWR (kW)	SINGLE POINT KIT PART NUMBER CRSINGLEXXXXA00			
						NO C.O. or Unpowered C.O.		w/PWRD C.O.	
						NO P.E.	w/ P.E. (pwrd fr/unit)	NO P.E.	w/ P.E. (pwrd fr/unit)
558J-08D (2-Circuit / 2-Stage Cooling)	208/230-3-60	STD	117A00	10.4	7.8/9.6	042	042	042	042
			110A00	16.0	12.0/14.7	042	042	043	043
			111A00	24.8	18.6/22.8	043	043	043	043
			112A00	32.0	24.0/29.4	043	043	043	043
			112A00,117A00	42.4	31.8/38.9	045	045	045	045
		MED	117A00	10.4	7.8/9.6	042	042	042	042
			110A00	16.0	12.0/14.7	042	043	043	043
			111A00	24.8	18.6/22.8	043	043	043	043
			112A00	32.0	24.0/29.4	043	043	043	043
			112A00,117A00	42.4	31.8/38.9	045	045	045	045
		HIGH	117A00	10.4	7.8/9.6	042	042	042	042
			110A00	16.0	12.0/14.7	043	043	043	043
	111A00		24.8	18.6/22.8	043	043	043	043	
	112A00		32.0	24.0/29.4	043	043	043	043	
	112A00,117A00		42.4	31.8/38.9	045	045	045	045	
	460-3-60	STD	116B00	13.9	12.8	042	042	042	042
			113B00	16.5	15.2	042	042	042	042
			114B00	27.8	25.5	042	042	042	042
			115B00	33.0	30.3	042	042	042	042
			128B00	41.7	38.3	044	044	044	044
			116B00	13.9	12.8	042	042	042	042
		MED	113B00	16.5	15.2	042	042	042	042
			114B00	27.8	25.5	042	042	042	042
			115B00	33.0	30.3	042	042	042	042
			128B00	41.7	38.3	044	044	044	044
		HIGH	116B00	13.9	12.8	042	042	042	042
			113B00	16.5	15.2	042	042	042	042
	114B00		27.8	25.5	042	042	042	042	
	115B00		33.0	30.3	042	042	044	044	
	575-3-60	STD	118A00	18.0	16.5	042	042	042	042
			119A00	36.0	33.1	042	042	042	042
		MED	118A00	18.0	16.5	042	042	042	042
			119A00	36.0	33.1	042	042	042	042
		HIGH	118A00	18.0	16.5	042	042	042	042
			119A00	36.0	33.1	042	042	042	042

LEGEND

- APP PWR — 208 / 230V / 460V / 575V
- C.O. — Convenience outlet
- FLA — Full load amps
- IFM — Indoor fan motor
- NOM PWR — 240V / 480V / 600V
- P.E. — Power exhaust
- PWRD — Powered convenience outlet
- UNPWRD — Unpowered convenience outlet

**SINGLE SPEED INDOOR FAN MOTOR
WITHOUT FACTORY INSTALLED NON-FUSED DISCONNECT**

UNIT SIZE	NOM. V-PH-HZ	IFM TYPE	ELECTRIC HEATER PART NUMBER CRHEATERXXXXXX	NOM PWR (kW)	APP PWR (kW)	SINGLE POINT KIT PART NUMBER CRSINGLEXXXA00			
						NO C.O. or Unpowered C.O.		w/PWRD C.O.	
						NO P.E.	w/ P.E. (pwrd fr/unit)	NO P.E.	w/ P.E. (pwrd fr/unit)
558J-09D (2-Circuit / 2-Stage Cooling)	208/203-3-60	STD	117A00	10.4	7.8/9.6	047	047	047	047
			110A00	16.0	12.0/14.7	047	047	049	049
			111A00	24.8	18.6/22.8	049	049	049	049
			112A00	32.0	24.0/29.4	049	049	049	049
			112A00,117A00	42.4	31.8/38.9	051	051	051	051
		MED	117A00	10.4	7.8/9.6	047	047	047	047
			110A00	16.0	12.0/14.7	047	049	049	049
			111A00	24.8	18.6/22.8	049	049	049	049
			112A00	32.0	24.0/29.4	049	049	049	049
			112A00,117A00	42.4	31.8/38.9	051	051	051	051
		HIGH	117A00	10.4	7.8/9.6	047	047	047	047
			110A00	16.0	12.0/14.7	049	049	049	049
	111A00		24.8	18.6/22.8	049	049	049	049	
	112A00		32.0	24.0/29.4	049	049	049	049	
	112A00,117A00		42.4	31.8/38.9	051	051	051	051	
	460-3-60	STD	116B00	13.9	12.8	047	047	047	047
			113B00	16.5	15.2	047	047	047	047
			114B00	27.8	25.5	047	047	047	047
			115B00	33.0	30.3	047	047	047	047
			128B00	41.7	38.3	050	050	050	050
		MED	116B00	13.9	12.8	047	047	047	047
			113B00	16.5	15.2	047	047	047	047
			114B00	27.8	25.5	047	047	047	047
			115B00	33.0	30.3	047	047	047	047
			128B00	41.7	38.3	050	050	050	050
		HIGH	116B00	13.9	12.8	047	047	047	047
			113B00	16.5	15.2	047	047	047	047
	114B00		27.8	25.5	047	047	047	047	
	115B00		33.0	30.3	047	047	047	050	
	128B00		41.7	38.3	050	050	050	050	
	575-3-60	STD	118A00	18.0	16.5	047	047	047	047
			119A00	36.0	33.1	047	047	047	047
		MED	118A00	18.0	16.5	047	047	047	047
			119A00	36.0	33.1	047	047	047	047
		HIGH	118A00	18.0	16.5	047	047	047	047
			119A00	36.0	33.1	047	047	047	047

LEGEND

- APP PWR — 208 / 230V / 460V / 575V
- C.O. — Convenience outlet
- FLA — Full load amps
- IFM — Indoor fan motor
- NOM PWR — 240V / 480V / 600V
- P.E. — Power exhaust
- PWRD — Powered convenience outlet
- UNPWRD — Unpowered convenience outlet

ELECTRICAL DATA (CONT)

SINGLE SPEED INDOOR FAN MOTOR WITHOUT FACTORY INSTALLED NON-FUSED DISCONNECT (cont)

UNIT SIZE	NOM. V-PH-HZ	IFM TYPE	ELECTRIC HEATER PART NUMBER CRHEATERXXXXXX	NOM PWR (kW)	APP PWR (kW)	SINGLE POINT KIT PART NUMBER CRSINGLEXXXXA00			
						NO C.O. or Unpowered C.O.		w/PWRD C.O.	
						NO P.E.	w/ P.E. (pwrdr fr/unit)	NO P.E.	w/ P.E. (pwrdr fr/unit)
558J-09N (1-Circuit / 2-Stage Cooling)	208/203-3-60	STD	117A00	10.4	7.8/9.6	047	047	047	049
			110A00	16.0	12.0/14.7	047	047	049	049
			111A00	24.8	18.6/22.8	049	049	049	049
			112A00	32.0	24.0/29.4	049	049	049	049
			112A00,117A00	42.4	31.8/38.9	051	051	051	051
		MED	117A00	10.4	7.8/9.6	047	047	047	049
			110A00	16.0	12.0/14.7	047	049	049	049
			111A00	24.8	18.6/22.8	049	049	049	049
			112A00	32.0	24.0/29.4	049	049	049	049
			112A00,117A00	42.4	31.8/38.9	051	051	051	051
		HIGH	117A00	10.4	7.8/9.6	047	049	049	049
			110A00	16.0	12.0/14.7	049	049	049	049
	111A00		24.8	18.6/22.8	049	049	049	049	
	112A00		32.0	24.0/29.4	049	049	049	049	
	112A00,117A00		42.4	31.8/38.9	051	051	051	051	
	460-3-60	STD	116B00	13.9	12.8	047	047	047	047
			113B00	16.5	15.2	047	047	047	047
			114B00	27.8	25.5	047	047	047	047
			115B00	33.0	30.3	047	047	047	047
			128B00	41.7	38.3	050	050	050	050
		MED	116B00	13.9	12.8	047	047	047	047
			113B00	16.5	15.2	047	047	047	047
			114B00	27.8	25.5	047	047	047	047
			115B00	33.0	30.3	047	047	047	047
			128B00	41.7	38.3	050	050	050	050
		HIGH	116B00	13.9	12.8	047	047	047	047
			113B00	16.5	15.2	047	047	047	047
	114B00		27.8	25.5	047	047	047	047	
	115B00		33.0	30.3	047	047	047	050	
	128B00		41.7	38.3	050	050	050	050	
	575-3-60	STD	118A00	18.0	16.5	047	047	047	047
			119A00	36.0	33.1	047	047	047	047
		MED	118A00	18.0	16.5	047	047	047	047
			119A00	36.0	33.1	047	047	047	047
		HIGH	118A00	18.0	16.5	047	047	047	047
			119A00	36.0	33.1	047	047	047	047

LEGEND

- APP PWR — 208 / 230V / 460V / 575V
- C.O. — Convenience outlet
- FLA — Full load amps
- IFM — Indoor fan motor
- NOM PWR — 240V / 480V / 600V
- P.E. — Power exhaust
- PWRD — Powered convenience outlet
- UNPWRD — Unpowered convenience outlet

**SINGLE SPEED INDOOR FAN MOTOR
WITH FACTORY INSTALLED NON-FUSED DISCONNECT (cont)**

UNIT SIZE	NOM. V-PH-HZ	IFM TYPE	ELECTRIC HEATER PART NUMBER CRHEATERXXXXXX	NOM PWR (kW)	APP PWR (kW)	SINGLE POINT KIT PART NUMBER CRSINGLEXXXA00			
						NO C.O. or Unpowered C.O.		w/PWRD C.O.	
						NO P.E.	w/ P.E. (pwrd fr/unit)	NO P.E.	w/ P.E. (pwrd fr/unit)
558J-09D (2-Circuit / 2-Stage Cooling)	208/203-3-60	STD	117A00	10.4	7.8/9.6	047	047	047	047
			110A00	16.0	12.0/14.7	047	047	049	049
			111A00	24.8	18.6/22.8	049	049	049	049
			112A00	32.0	24.0/29.4	049	049	049	049
			112A00,117A00	42.4	31.8/38.9	051	051	051	051
		MED	117A00	10.4	7.8/9.6	047	047	047	047
			110A00	16.0	12.0/14.7	047	049	049	049
			111A00	24.8	18.6/22.8	049	049	049	049
			112A00	32.0	24.0/29.4	049	049	049	049
			112A00,117A00	42.4	31.8/38.9	051	051	051	051
		HIGH	117A00	10.4	7.8/9.6	047	047	047	047
			110A00	16.0	12.0/14.7	049	049	049	049
			111A00	24.8	18.6/22.8	049	049	049	049
			112A00	32.0	24.0/29.4	049	049	049	049
			112A00,117A00	42.4	31.8/38.9	051	051	051	051
	460-3-60	STD	116B00	13.9	12.8	047	047	047	047
			113B00	16.5	15.2	047	047	047	047
			114B00	27.8	25.5	047	047	047	047
			115B00	33.0	30.3	047	047	047	047
			128B00	41.7	38.3	050	050	050	050
		MED	116B00	13.9	12.8	047	047	047	047
			113B00	16.5	15.2	047	047	047	047
			114B00	27.8	25.5	047	047	047	047
			115B00	33.0	30.3	047	047	047	047
			128B00	41.7	38.3	050	050	050	050
		HIGH	116B00	13.9	12.8	047	047	047	047
			113B00	16.5	15.2	047	047	047	047
			114B00	27.8	25.5	047	047	047	047
			115B00	33.0	30.3	047	047	047	050
			128B00	41.7	38.3	050	050	050	050
	575-3-60	STD	118A00	18.0	16.5	047	047	047	047
			119A00	36.0	33.1	047	047	047	047
		MED	118A00	18.0	16.5	047	047	047	047
			119A00	36.0	33.1	047	047	047	047
		HIGH	118A00	18.0	16.5	047	047	047	047
	119A00		36.0	33.1	047	047	047	047	

LEGEND

- APP PWR — 208 / 230V / 460V / 575V
- C.O. — Convenience outlet
- FLA — Full load amps
- IFM — Indoor fan motor
- NOM PWR — 240V / 480V / 600V
- P.E. — Power exhaust
- PWRD — Powered convenience outlet
- UNPWRD — Unpowered convenience outlet

ELECTRICAL DATA (CONT)

SINGLE SPEED INDOOR FAN MOTOR WITH FACTORY INSTALLED NON-FUSED DISCONNECT (cont)

UNIT SIZE	NOM. V-PH-HZ	IFM TYPE	ELECTRIC HEATER PART NUMBER CRHEATERXXXXXX	NOM PWR (kW)	APP PWR (kW)	SINGLE POINT KIT PART NUMBER CRSINGLEXXXXA00			
						NO C.O. or Unpowered C.O.		w/PWRD C.O.	
						NO P.E.	w/ P.E. (pwrd fr/unit)	NO P.E.	w/ P.E. (pwrd fr/unit)
558J-09N (1-Circuit / 2-Stage Cooling)	208/203-3-60	STD	117A00	10.4	7.8/9.6	047	047	047	049
			110A00	16.0	12.0/14.7	047	047	049	049
			111A00	24.8	18.6/22.8	049	049	049	049
			112A00	32.0	24.0/29.4	049	049	049	049
			112A00,117A00	42.4	31.8/38.9	051	051	051	051
		MED	117A00	10.4	7.8/9.6	047	047	047	049
			110A00	16.0	12.0/14.7	047	049	049	049
			111A00	24.8	18.6/22.8	049	049	049	049
			112A00	32.0	24.0/29.4	049	049	049	049
			112A00,117A00	42.4	31.8/38.9	051	051	051	051
		HIGH	117A00	10.4	7.8/9.6	047	049	049	049
			110A00	16.0	12.0/14.7	049	049	049	049
	111A00		24.8	18.6/22.8	049	049	049	049	
	112A00		32.0	24.0/29.4	049	049	049	049	
	112A00,117A00		42.4	31.8/38.9	051	051	051	051	
	460-3-60	STD	116B00	13.9	12.8	047	047	047	047
			113B00	16.5	15.2	047	047	047	047
			114B00	27.8	25.5	047	047	047	047
			115B00	33.0	30.3	047	047	047	047
			128B00	41.7	38.3	050	050	050	050
		MED	116B00	13.9	12.8	047	047	047	047
			113B00	16.5	15.2	047	047	047	047
			114B00	27.8	25.5	047	047	047	047
			115B00	33.0	30.3	047	047	047	047
			128B00	41.7	38.3	050	050	050	050
		HIGH	116B00	13.9	12.8	047	047	047	047
			113B00	16.5	15.2	047	047	047	047
	114B00		27.8	25.5	047	047	047	047	
	115B00		33.0	30.3	047	047	047	050	
	128B00		41.7	38.3	050	050	050	050	
	575-3-60	STD	118A00	18.0	16.5	047	047	047	047
			119A00	36.0	33.1	047	047	047	047
		MED	118A00	18.0	16.5	047	047	047	047
			119A00	36.0	33.1	047	047	047	047
		HIGH	118A00	18.0	16.5	047	047	047	047
			119A00	36.0	33.1	047	047	047	047

LEGEND

- APP PWR — 208 / 230V / 460V / 575V
- C.O. — Convenience outlet
- FLA — Full load amps
- IFM — Indoor fan motor
- NOM PWR — 240V / 480V / 600V
- P.E. — Power exhaust
- PWRD — Powered convenience outlet
- UNPWRD — Unpowered convenience outlet

**2-SPEED INDOOR FAN MOTOR
WITH OR WITHOUT FACTORY INSTALLED NON-FUSED DISCONNECT**

UNIT SIZE	NOM. V-PH-HZ	IFM TYPE	ELECTRIC HEATER PART NUMBER CRHEATERXXXXXX	NOM PWR (kW)	APP PWR (kW)	SINGLE POINT KIT PART NUMBER CRSINGLEXXA00			
						NO C.O. or Unpowered C.O.		w/PWRD C.O.	
						NO P.E.	w/ P.E. (pwrd fr/unit)	NO P.E.	w/ P.E. (pwrd fr/unit)
558J-09D (2-Circuit / 2-Stage Cooling)	208/203-3-60	STD	117A00	10.4	7.8/9.6	047	047	047	047
			110A00	16.0	12.0/14.7	047	047	049	049
			111A00	24.8	18.6/22.8	049	049	049	049
			112A00	32.0	24.0/29.4	049	049	049	049
			112A00,117A00	42.4	31.8/38.9	051	051	051	051
		MED	117A00	10.4	7.8/9.6	047	047	047	047
			110A00	16.0	12.0/14.7	047	049	049	049
			111A00	24.8	18.6/22.8	049	049	049	049
			112A00	32.0	24.0/29.4	049	049	049	049
			112A00,117A00	42.4	31.8/38.9	051	051	051	051
		HIGH	117A00	10.4	7.8/9.6	047	047	047	047
			110A00	16.0	12.0/14.7	049	049	049	049
			111A00	24.8	18.6/22.8	049	049	049	049
			112A00	32.0	24.0/29.4	049	049	049	049
			112A00,117A00	42.4	31.8/38.9	051	051	051	051
	460-3-60	STD	116B00	13.9	12.8	047	047	047	047
			113B00	16.5	15.2	047	047	047	047
			114B00	27.8	25.5	047	047	047	047
			115B00	33.0	30.3	047	047	047	047
			128B00	41.7	38.3	050	050	050	050
		MED	116B00	13.9	12.8	047	047	047	047
			113B00	16.5	15.2	047	047	047	047
			114B00	27.8	25.5	047	047	047	047
			115B00	33.0	30.3	047	047	047	047
			128B00	41.7	38.3	050	050	050	050
		HIGH	116B00	13.9	12.8	047	047	047	047
			113B00	16.5	15.2	047	047	047	047
			114B00	27.8	25.5	047	047	047	047
			115B00	33.0	30.3	047	047	047	050
			128B00	41.7	38.3	050	050	050	050
	575-3-60	STD	118A00	18.0	16.5	047	047	047	047
			119A00	36.0	33.1	047	047	047	047
		MED	118A00	18.0	16.5	047	047	047	047
			119A00	36.0	33.1	047	047	047	047
		HIGH	118A00	18.0	16.5	047	047	047	047
			119A00	36.0	33.1	047	047	047	047

LEGEND

- APP PWR — 208 / 230V / 460V / 575V
- C.O. — Convenience outlet
- FLA — Full load amps
- IFM — Indoor fan motor
- NOM PWR — 240V / 480V / 600V
- P.E. — Power exhaust
- PWRD — Powered convenience outlet
- UNPWRD — Unpowered convenience outlet

ELECTRICAL DATA (CONT)

SINGLE SPEED INDOOR FAN MOTOR WITHOUT FACTORY INSTALLED NON-FUSED DISCONNECT

UNIT SIZE	NOM. V-PH-HZ	IFM TYPE	ELECTRIC HEATER PART NUMBER CRHEATERXXXXXX	NOM PWR (kW)	APP PWR (kW)	SINGLE POINT KIT PART NUMBER CRSINGLEXXXXA00			
						NO C.O. or Unpowered C.O.		w/PWRD C.O.	
						NO P.E.	w/ P.E. (pwrd fr/unit)	NO P.E.	w/ P.E. (pwrd fr/unit)
558J-12D (2-Circuit / 2-Stage Cooling)	208/230-3-60	STD	117A00	10.4	7.8/9.6	047	047	047	047
			110A00	16.0	12.0/14.7	047	047	049	049
			112A00	32.0	24.0/29.4	049	049	049	049
			112A00,117A00	42.4	31.8/38.9	051	051	051	051
			112A00,110A00	50.0	37.6/45.9	051	051	051	051
		MED	117A00	10.4	7.8/9.6	047	047	047	049
			110A00	16.0	12.0/14.7	049	049	049	049
			112A00	32.0	24.0/29.4	049	049	049	049
			112A00,117A00	42.4	31.8/38.9	051	051	051	051
			112A00,110A00	50.0	37.6/45.9	051	051	051	051
		HIGH	117A00	10.4	7.8/9.6	047	047	049	049
			110A00	16.0	12.0/14.7	049	049	049	049
	112A00		32.0	24.0/29.4	049	049	049	049	
	112A00,117A00		42.4	31.8/38.9	051	051	051	051	
	112A00,110A00		50.0	37.6/45.9	051	051	051	051	
	460-3-60	STD	116B00	13.9	12.8	047	047	047	047
			113B00	16.5	15.2	047	047	047	047
			115B00	33.0	30.3	047	047	047	047
			128B00	41.7	38.3	050	050	050	050
			129B00	50.0	45.9	050	050	050	050
		MED	116B00	13.9	12.8	047	047	047	047
			113B00	16.5	15.2	047	047	047	047
			115B00	33.0	30.3	047	047	047	050
			128B00	41.7	38.3	050	050	050	050
			129B00	50.0	45.9	050	050	050	050
		HIGH	116B00	13.9	12.8	047	047	047	047
			113B00	16.5	15.2	047	047	047	047
	115B00		33.0	30.3	047	047	050	050	
	128B00		41.7	38.3	050	050	050	050	
	129B00		50.0	45.9	050	050	050	050	
	575-3-60	STD	118A00	18.0	16.5	047	047	047	047
			119A00	36.0	33.1	047	047	047	047
			118A00,119A00	54.0	49.6	047	047	047	050
		MED	118A00	18.0	16.5	047	047	047	047
			119A00	36.0	33.1	047	047	047	047
			118A00,119A00	54.0	49.6	047	050	047	050
HIGH		118A00	18.0	16.5	047	047	047	047	
		119A00	36.0	33.1	047	047	047	047	
		118A00,119A00	54.0	49.6	050	050	050	050	

LEGEND

- APP PWR — 208 / 230V / 460V / 575V
- C.O. — Convenience outlet
- FLA — Full load amps
- IFM — Indoor fan motor
- NOM PWR — 240V / 480V / 600V
- P.E. — Power exhaust
- PWRD — Powered convenience outlet
- UNPWRD — Unpowered convenience outlet

**SINGLE SPEED INDOOR FAN MOTOR
WITHOUT FACTORY INSTALLED NON-FUSED DISCONNECT (cont)**

UNIT SIZE	NOM. V-PH-HZ	IFM TYPE	ELECTRIC HEATER PART NUMBER CRHEATERXXXXXX	NOM PWR (kW)	APP PWR (kW)	SINGLE POINT KIT PART NUMBER CRSINGLEXXA00			
						NO C.O. or Unpowered C.O.		w/PWRD C.O.	
						NO P.E.	w/ P.E. (pwrd fr/unit)	NO P.E.	w/ P.E. (pwrd fr/unit)
558-J-12D (1-Circuit / 2-Stage Cooling)	208/230-3-60	STD	117A00	10.4	7.8/9.6	047	049	049	049
			110A00	16.0	12.0/14.7	047	049	049	049
			112A00	32.0	24.0/29.4	049	049	049	049
			112A00,117A00	42.4	31.8/38.9	051	051	051	051
			112A00,110A00	50.0	37.6/45.9	051	051	051	051
		MED	117A00	10.4	7.8/9.6	049	049	049	049
			110A00	16.0	12.0/14.7	049	049	049	049
			112A00	32.0	24.0/29.4	049	049	049	049
			112A00,117A00	42.4	31.8/38.9	051	051	051	051
		HIGH	112A00,110A00	50.0	37.6/45.9	051	051	051	051
			117A00	10.4	7.8/9.6	049	049	049	049
			110A00	16.0	12.0/14.7	049	049	049	049
	112A00		32.0	24.0/29.4	049	049	049	049	
	112A00,117A00		42.4	31.8/38.9	051	051	051	051	
	460-3-60	STD	117A00	10.4	7.8/9.6	049	049	049	049
			110A00	16.0	12.0/14.7	049	049	049	049
			112A00	32.0	24.0/29.4	049	049	049	049
			112A00,117A00	42.4	31.8/38.9	051	051	051	051
			112A00,110A00	50.0	37.6/45.9	051	051	051	051
		MED	117A00	10.4	7.8/9.6	049	049	049	049
			110A00	16.0	12.0/14.7	049	049	049	049
			112A00	32.0	24.0/29.4	049	049	049	049
			112A00,117A00	42.4	31.8/38.9	051	051	051	051
		HIGH	112A00,110A00	50.0	37.6/45.9	051	051	051	051
			117A00	10.4	7.8/9.6	049	049	049	049
			110A00	16.0	12.0/14.7	049	049	049	049
	112A00		32.0	24.0/29.4	049	049	049	049	
	112A00,117A00		42.4	31.8/38.9	051	051	051	051	
	575-3-60	STD	116B00	13.9	12.8	047	047	047	047
			113B00	16.5	15.2	047	047	047	047
			115B00	33.0	30.3	047	047	047	047
		MED	128B00	41.7	38.3	050	050	050	050
			129B00	50.0	45.9	050	050	050	050
			116B00	13.9	12.8	047	047	047	047
			113B00	16.5	15.2	047	047	047	047
			115B00	33.0	30.3	047	047	047	047
HIGH		128B00	41.7	38.3	050	050	050	050	
		129B00	50.0	45.9	050	050	050	050	
		116B00	13.9	12.8	047	047	047	047	
		113B00	16.5	15.2	047	047	047	047	
STD	118A00	18.0	16.5	047	047	047	047		
	119A00	36.0	33.1	047	047	047	047		
	118A00,119A00	54.0	49.6	047	047	047	050		
	118A00	18.0	16.5	047	047	047	047		
	119A00	36.0	33.1	047	047	047	047		
	118A00,119A00	54.0	49.6	047	050	047	050		
MED	118A00	18.0	16.5	047	047	047	047		
	119A00	36.0	33.1	047	047	047	047		
	118A00,119A00	54.0	49.6	047	050	047	050		
HIGH	118A00	18.0	16.5	047	047	047	047		
	119A00	36.0	33.1	047	047	047	047		
	118A00,119A00	54.0	49.6	050	050	050	050		

LEGEND

- APP PWR — 208 / 230V / 460V / 575V
- C.O. — Convenience outlet
- FLA — Full load amps
- IFM — Indoor fan motor
- NOM PWR — 240V / 480V / 600V
- P.E. — Power exhaust
- PWRD — Powered convenience outlet
- UNPWRD — Unpowered convenience outlet

ELECTRICAL DATA (CONT)

SINGLE SPEED INDOOR FAN MOTOR WITH FACTORY INSTALLED NON-FUSED DISCONNECT

UNIT SIZE	NOM. V-PH-HZ	IFM TYPE	ELECTRIC HEATER PART NUMBER CRHEATERXXXXXX	NOM PWR (kW)	APP PWR (kW)	SINGLE POINT KIT PART NUMBER CRSINGLEXXXXA00			
						NO C.O. or Unpowered C.O.		w/PWRD C.O.	
						NO P.E.	w/ P.E. (pwrd fr/unit)	NO P.E.	w/ P.E. (pwrd fr/unit)
558J-12D (2-Circuit / 2-Speed Cooling)	208/230-3-60	STD	117A00	10.4	7.8/9.6	047	047	047	047
			110A00	16.0	12.0/14.7	047	047	049	049
			112A00	32.0	24.0/29.4	049	049	049	049
			112A00,117A00	42.4	31.8/38.9	051	051	051	051
			112A00,110A00	50.0	37.6/45.9	051	051	051	051
		MED	117A00	10.4	7.8/9.6	047	047	047	049
			110A00	16.0	12.0/14.7	049	049	049	049
			112A00	32.0	24.0/29.4	049	049	049	049
			112A00,117A00	42.4	31.8/38.9	051	051	051	051
			112A00,110A00	50.0	37.6/45.9	051	051	051	051
		HIGH	117A00	10.4	7.8/9.6	047	047	049	049
			110A00	16.0	12.0/14.7	049	049	049	049
			112A00	32.0	24.0/29.4	049	049	049	049
			112A00,117A00	42.4	31.8/38.9	051	051	051	051
			112A00,110A00	50.0	37.6/45.9	051	051	051	051
	460-3-60	STD	116B00	13.9	12.8	047	047	047	047
			113B00	16.5	15.2	047	047	047	047
			115B00	33.0	30.3	047	047	047	047
			128B00	41.7	38.3	050	050	050	050
			129B00	50.0	45.9	050	050	050	050
		MED	116B00	13.9	12.8	047	047	047	047
			113B00	16.5	15.2	047	047	047	047
			115B00	33.0	30.3	047	047	047	050
			128B00	41.7	38.3	050	050	050	050
			129B00	50.0	45.9	050	050	050	050
		HIGH	116B00	13.9	12.8	047	047	047	047
			113B00	16.5	15.2	047	047	047	047
			115B00	33.0	30.3	047	047	050	050
			128B00	41.7	38.3	050	050	050	050
			129B00	50.0	45.9	050	050	050	050
	575-3-60	STD	118A00	18.0	16.5	047	047	047	047
			119A00	36.0	33.1	047	047	047	047
			118A00,119A00	54.0	49.6	047	047	047	050
		MED	118A00	18.0	16.5	047	047	047	047
			119A00	36.0	33.1	047	047	047	047
			118A00,119A00	54.0	49.6	047	050	047	050
HIGH		118A00	18.0	16.5	047	047	047	047	
		119A00	36.0	33.1	047	047	047	047	
		118A00,119A00	54.0	49.6	050	050	050	050	

LEGEND

- APP PWR — 208 / 230V / 460V / 575V
- C.O. — Convenience outlet
- FLA — Full load amps
- IFM — Indoor fan motor
- NOM PWR — 240V / 480V / 600V
- P.E. — Power exhaust
- PWRD — Powered convenience outlet
- UNPWRD — Unpowered convenience outlet

**SINGLE SPEED INDOOR FAN MOTOR
WITH FACTORY INSTALLED NON-FUSED DISCONNECT (cont)**

UNIT SIZE	NOM. V-PH-HZ	IFM TYPE	ELECTRIC HEATER PART NUMBER CRHEATERXXXXXX	NOM PWR (kW)	APP PWR (kW)	SINGLE POINT KIT PART NUMBER CRSINGLEXXXA00			
						NO C.O. or Unpowered C.O.		w/PWRD C.O.	
						NO P.E.	w/ P.E. (pwrd fr/unit)	NO P.E.	w/ P.E. (pwrd fr/unit)
558J-12N (1-Circuit / 2-Speed Cooling)	208/230-3-60	STD	117A00	10.4	7.8/9.6	047	049	049	049
			110A00	16.0	12.0/14.7	047	049	049	049
			112A00	32.0	24.0/29.4	049	049	049	049
			112A00,117A00	42.4	31.8/38.9	051	051	051	051
			112A00,110A00	50.0	37.6/45.9	051	051	051	051
		MED	117A00	10.4	7.8/9.6	049	049	049	049
			110A00	16.0	12.0/14.7	049	049	049	049
			112A00	32.0	24.0/29.4	049	049	049	049
			112A00,117A00	42.4	31.8/38.9	051	051	051	051
		HIGH	112A00,110A00	50.0	37.6/45.9	051	051	051	051
			117A00	10.4	7.8/9.6	049	049	049	049
			110A00	16.0	12.0/14.7	049	049	049	049
	112A00		32.0	24.0/29.4	049	049	049	049	
	112A00,117A00		42.4	31.8/38.9	051	051	051	051	
	460-3-60	STD	117A00	10.4	7.8/9.6	049	049	049	049
			110A00	16.0	12.0/14.7	049	049	049	049
			112A00	32.0	24.0/29.4	049	049	049	049
			112A00,117A00	42.4	31.8/38.9	051	051	051	051
			112A00,110A00	50.0	37.6/45.9	051	051	051	051
		MED	116B00	13.9	12.8	047	047	047	047
			113B00	16.5	15.2	047	047	047	047
			115B00	33.0	30.3	047	047	047	047
			128B00	41.7	38.3	050	050	050	050
		HIGH	129B00	50.0	45.9	050	050	050	050
			116B00	13.9	12.8	047	047	047	047
			113B00	16.5	15.2	047	047	047	047
	115B00		33.0	30.3	047	047	047	047	
	128B00		41.7	38.3	050	050	050	050	
	575-3-60	STD	129B00	50.0	45.9	050	050	050	050
			116B00	13.9	12.8	047	047	047	047
			113B00	16.5	15.2	047	047	047	047
		MED	115B00	33.0	30.3	047	047	047	047
			128B00	41.7	38.3	050	050	050	050
			118A00	18.0	16.5	047	047	047	047
			119A00	36.0	33.1	047	047	047	047
		HIGH	118A00,119A00	54.0	49.6	047	047	047	050
118A00			18.0	16.5	047	047	047	047	
119A00			36.0	33.1	047	047	047	047	
118A00,119A00			54.0	49.6	047	050	047	050	
118A00			18.0	16.5	047	047	047	047	
119A00	36.0	33.1	047	047	047	047			
118A00,119A00	54.0	49.6	050	050	050	050			

LEGEND

- APP PWR — 208 / 230V / 460V / 575V
- C.O. — Convenience outlet
- FLA — Full load amps
- IFM — Indoor fan motor
- NOM PWR — 240V / 480V / 600V
- P.E. — Power exhaust
- PWRD — Powered convenience outlet
- UNPWRD — Unpowered convenience outlet

ELECTRICAL DATA (CONT)

2-SPEED INDOOR FAN MOTOR WITH OR WITHOUT FACTORY INSTALLED NON-FUSED DISCONNECT

UNIT SIZE	NOM. V-PH-HZ	IFM TYPE	ELECTRIC HEATER PART NUMBER CRHEATERXXXXXX	NOM PWR (kW)	APP PWR (kW)	SINGLE POINT KIT PART NUMBER CRSINGLEXXXXA00			
						NO C.O. or Unpowered C.O.		w/PWRD C.O.	
						NO P.E.	w/ P.E. (pwrd fr/unit)	NO P.E.	w/ P.E. (pwrd fr/unit)
558J-12D (2-Circuit / 2-Stage Cooling)	208/230-3-60	STD	117A00	10.4	7.8/9.6	047	047	047	047
			110A00	16.0	12.0/14.7	047	049	049	049
			112A00	32.0	24.0/29.4	049	049	049	049
			112A00,117A00	42.4	31.8/38.9	051	051	051	051
			112A00,110A00	50.0	37.6/45.9	051	051	051	051
		MED	117A00	10.4	7.8/9.6	047	047	047	049
			110A00	16.0	12.0/14.7	049	049	049	049
			112A00	32.0	24.0/29.4	049	049	049	049
			112A00,117A00	42.4	31.8/38.9	051	051	051	051
			112A00,110A00	50.0	37.6/45.9	051	051	051	051
		HIGH	117A00	10.4	7.8/9.6	047	047	049	049
			110A00	16.0	12.0/14.7	049	049	049	049
	112A00		32.0	24.0/29.4	049	049	049	049	
	112A00,117A00		42.4	31.8/38.9	051	051	051	051	
	112A00,110A00		50.0	37.6/45.9	051	051	051	051	
	460-3-60	STD	116B00	13.9	12.8	047	047	047	047
			113B00	16.5	15.2	047	047	047	047
			115B00	33.0	30.3	047	047	047	047
			128B00	41.7	38.3	050	050	050	050
			129B00	50.0	45.9	050	050	050	050
		MED	116B00	13.9	12.8	047	047	047	047
			113B00	16.5	15.2	047	047	047	047
			115B00	33.0	30.3	047	047	047	050
			128B00	41.7	38.3	050	050	050	050
			129B00	50.0	45.9	050	050	050	050
		HIGH	116B00	13.9	12.8	047	047	047	047
			113B00	16.5	15.2	047	047	047	047
	115B00		33.0	30.3	047	047	050	050	
	128B00		41.7	38.3	050	050	050	050	
	129B00		50.0	45.9	050	050	050	050	
	575-3-60	STD	118A00	18.0	16.5	047	047	047	047
			119A00	36.0	33.1	047	047	047	047
			118A00,119A00	54.0	49.6	047	050	047	050
		MED	118A00	18.0	16.5	047	047	047	047
			119A00	36.0	33.1	047	047	047	047
			118A00,119A00	54.0	49.6	047	050	050	050
HIGH		118A00	18.0	16.5	047	047	047	047	
		119A00	36.0	33.1	047	047	047	047	
		118A00,119A00	54.0	49.6	050	050	050	050	

LEGEND

- APP PWR — 208 / 230V / 460V / 575V
- C.O. — Convenience outlet
- FLA — Full load amps
- IFM — Indoor fan motor
- NOM PWR — 240V / 480V / 600V
- P.E. — Power exhaust
- PWRD — Powered convenience outlet
- UNPWRD — Unpowered convenience outlet

**SINGLE SPEED INDOOR FAN MOTOR
WITHOUT FACTORY INSTALLED NON-FUSED DISCONNECT**

UNIT SIZE	NOM. V-PH-HZ	IFM TYPE	ELECTRIC HEATER PART NUMBER CRHEATERXXXXXX	NOM PWR (kW)	APP PWR (kW)	SINGLE POINT KIT PART NUMBER CRSINGLEXXXA00			
						NO C.O. or Unpowered C.O.		w/PWRD C.O.	
						NO P.E.	w/ P.E. (pwrd fr/unit)	NO P.E.	w/ P.E. (pwrd fr/unit)
558-14D (2-Circuit / 2-Speed Cooling)	208/230-3-60	STD	117A00	10.4	7.8/9.6	049	049	049	049
			110A00	16.0	12.0/14.7	049	049	049	049
			112A00	32.0	24.0/29.4	049	049	049	049
			112A00,117A00	42.4	31.8/38.9	051	051	051	051
			112A00,110A00	50.0	37.6/45.9	051	051	051	051
		MED	117A00	10.4	7.8/9.6	049	049	049	049
			110A00	16.0	12.0/14.7	049	049	049	049
			112A00	32.0	24.0/29.4	049	049	049	049
			112A00,117A00	42.4	31.8/38.9	051	051	051	051
		HIGH	112A00,110A00	50.0	37.6/45.9	051	051	051	051
			117A00	10.4	7.8/9.6	049	049	049	049
			110A00	16.0	12.0/14.7	049	049	049	049
	112A00		32.0	24.0/29.4	049	049	049	049	
	112A00,117A00		42.4	31.8/38.9	051	051	051	051	
	460-3-60	STD	112A00,110A00	50.0	37.6/45.9	051	051	051	051
			116B00	13.9	12.8	047	047	047	047
			113B00	16.5	15.2	047	047	047	047
			115B00	33.0	30.3	047	047	047	047
			128B00	41.7	38.3	050	050	050	050
		MED	129B00	50.0	45.9	050	050	050	050
			116B00	13.9	12.8	047	047	047	047
			113B00	16.5	15.2	047	047	047	047
			115B00	33.0	30.3	047	047	047	050
		HIGH	128B00	41.7	38.3	050	050	050	050
			129B00	50.0	45.9	050	050	050	050
			116B00	13.9	12.8	047	047	047	047
	113B00		16.5	15.2	047	047	047	047	
	115B00		33.0	30.3	047	047	050	050	
	575-3-60	STD	128B00	41.7	38.3	050	050	050	050
			129B00	50.0	45.9	050	050	050	050
			118A00	18.0	16.5	047	047	047	047
		MED	119A00	36.0	33.1	047	047	047	047
			118A00,119A00	54.0	49.6	047	050	047	050
			118A00	18.0	16.5	047	047	047	047
		HIGH	119A00	36.0	33.1	047	047	047	047
			118A00,119A00	54.0	49.6	047	050	047	050
118A00			18.0	16.5	047	047	047	047	
			119A00	36.0	33.1	047	047	047	047
			118A00,119A00	54.0	49.6	050	050	050	050

LEGEND
APP PWR — 208 / 230V / 460V / 575V
C.O. — Convenience outlet
FLA — Full load amps
IFM — Indoor fan motor
NOM PWR — 240V / 480V / 600V
P.E. — Power exhaust
PWRD — Powered convenience outlet
UNPWRD — Unpowered convenience outlet

ELECTRICAL DATA (CONT)

SINGLE SPEED INDOOR FAN MOTOR WITH FACTORY INSTALLED NON-FUSED DISCONNECT

UNIT SIZE	NOM. V-PH-HZ	IFM TYPE	ELECTRIC HEATER PART NUMBER CRHEATERXXXXXX	NOM PWR (kW)	APP PWR (kW)	SINGLE POINT KIT PART NUMBER CRSINGLEXXXXA00			
						NO C.O. or Unpowered C.O.		w/PWRD C.O.	
						NO P.E.	w/ P.E. (pwrd fr/unit)	NO P.E.	w/ P.E. (pwrd fr/unit)
558J-14D (2-Circuit / 2-Stage Cooling)	208/230-3-60	STD	117A00	10.4	7.8/9.6	049	049	049	049
			110A00	16.0	12.0/14.7	049	049	049	049
			112A00	32.0	24.0/29.4	049	049	049	049
			112A00,117A00	42.4	31.8/38.9	051	051	051	051
			112A00,110A00	50.0	37.6/45.9	051	051	051	051
		MED	117A00	10.4	7.8/9.6	049	049	049	049
			110A00	16.0	12.0/14.7	049	049	049	049
			112A00	32.0	24.0/29.4	049	049	049	049
			112A00,117A00	42.4	31.8/38.9	051	051	051	051
			112A00,110A00	50.0	37.6/45.9	051	051	051	051
		HIGH	117A00	10.4	7.8/9.6	049	049	049	049
			110A00	16.0	12.0/14.7	049	049	049	049
	112A00		32.0	24.0/29.4	049	049	049	049	
	112A00,117A00		42.4	31.8/38.9	051	051	051	051	
	112A00,110A00		50.0	37.6/45.9	051	051	051	051	
	460-3-60	STD	116B00	13.9	12.8	047	047	047	047
			113B00	16.5	15.2	047	047	047	047
			115B00	33.0	30.3	047	047	047	047
			128B00	41.7	38.3	050	050	050	050
			129B00	50.0	45.9	050	050	050	050
		MED	116B00	13.9	12.8	047	047	047	047
			113B00	16.5	15.2	047	047	047	047
			115B00	33.0	30.3	047	047	047	050
			128B00	41.7	38.3	050	050	050	050
			129B00	50.0	45.9	050	050	050	050
		HIGH	116B00	13.9	12.8	047	047	047	047
			113B00	16.5	15.2	047	047	047	047
	115B00		33.0	30.3	047	047	050	050	
	128B00		41.7	38.3	050	050	050	050	
	129B00		50.0	45.9	050	050	050	050	
	575-3-60	STD	118A00	18.0	16.5	047	047	047	047
			119A00	36.0	33.1	047	047	047	047
			118A00,119A00	54.0	49.6	047	050	047	050
		MED	118A00	18.0	16.5	047	047	047	047
			119A00	36.0	33.1	047	047	047	047
			118A00,119A00	54.0	49.6	047	050	047	050
HIGH		118A00	18.0	16.5	047	047	047	047	
		119A00	36.0	33.1	047	047	047	047	
		118A00,119A00	54.0	49.6	050	050	050	050	

LEGEND

- APP PWR — 208 / 230V / 460V / 575V
- C.O. — Convenience outlet
- FLA — Full load amps
- IFM — Indoor fan motor
- NOM PWR — 240V / 480V / 600V
- P.E. — Power exhaust
- PWRD — Powered convenience outlet
- UNPWRD — Unpowered convenience outlet

**COOLING 2-SPEED INDOOR FAN MOTOR
WITH OR WITHOUT FACTORY INSTALLED NON-FUSED DISCONNECT**

UNIT SIZE	NOM. V-PH-HZ	IFM TYPE	ELECTRIC HEATER PART NUMBER CRHEATERXXXXXX	NOM PWR (kW)	APP PWR (kW)	SINGLE POINT KIT PART NUMBER CRSINGLEXXXA00			
						NO C.O. or Unpowered C.O.		w/PWRD C.O.	
						NO P.E.	w/ P.E. (pwrd fr/unit)	NO P.E.	w/ P.E. (pwrd fr/unit)
558J-14D (2-Circuit / 2-Stage Cooling)	208/230-3-60	STD	117A00	10.4	7.8/9.6	049	049	049	049
			110A00	16.0	12.0/14.7	049	049	049	049
			112A00	32.0	24.0/29.4	049	049	049	049
			112A00,117A00	42.4	31.8/38.9	051	051	051	051
			112A00,110A00	50.0	37.6/45.9	051	051	051	051
		MED	117A00	10.4	7.8/9.6	049	049	049	049
			110A00	16.0	12.0/14.7	049	049	049	049
			112A00	32.0	24.0/29.4	049	049	049	049
			112A00,117A00	42.4	31.8/38.9	051	051	051	051
			112A00,110A00	50.0	37.6/45.9	051	051	051	051
		HIGH	117A00	10.4	7.8/9.6	049	049	049	049
			110A00	16.0	12.0/14.7	049	049	049	049
	112A00		32.0	24.0/29.4	049	049	049	049	
	112A00,117A00		42.4	31.8/38.9	051	051	051	051	
	112A00,110A00		50.0	37.6/45.9	051	051	051	051	
	460-3-60	STD	116B00	13.9	12.8	047	047	047	047
			113B00	16.5	15.2	047	047	047	047
			115B00	33.0	30.3	047	047	047	047
			128B00	41.7	38.3	050	050	050	050
			129B00	50.0	45.9	050	050	050	050
		MED	116B00	13.9	12.8	047	047	047	047
			113B00	16.5	15.2	047	047	047	047
			115B00	33.0	30.3	047	047	047	050
			128B00	41.7	38.3	050	050	050	050
			129B00	50.0	45.9	050	050	050	050
		HIGH	116B00	13.9	12.8	047	047	047	047
			113B00	16.5	15.2	047	047	047	047
	115B00		33.0	30.3	047	047	050	050	
	128B00		41.7	38.3	050	050	050	050	
	129B00		50.0	45.9	050	050	050	050	
	575-3-60	STD	118A00	18.0	16.5	047	047	047	047
			119A00	36.0	33.1	047	047	047	047
			118A00,119A00	54.0	49.6	047	050	050	050
		MED	118A00	18.0	16.5	047	047	047	047
			119A00	36.0	33.1	047	047	047	047
			118A00,119A00	54.0	49.6	047	050	050	050
HIGH		118A00	18.0	16.5	047	047	047	047	
		119A00	36.0	33.1	047	047	047	047	
		118A00,119A00	54.0	49.6	050	050	050	050	

LEGEND

- APP PWR — 208 / 230V / 460V / 575V
- C.O. — Convenience outlet
- FLA — Full load amps
- IFM — Indoor fan motor
- NOM PWR — 240V / 480V / 600V
- P.E. — Power exhaust
- PWRD — Powered convenience outlet
- UNPWRD — Unpowered convenience outlet

ELECTRICAL DATA (CONT)

SINGLE SPEED INDOOR FAN MOTOR WITHOUT FACTORY INSTALLED NON-FUSED DISCONNECT

UNIT SIZE	NOM. V-PH-HZHZ	IFM TYPE	ELECTRIC HEATER PART NUMBER CRHEATERXXXXXX	NOM PWR (kW)	APP PWR (kW)	SINGLE POINT KIT PART NUMBER CRSINGLEXXXXA00				
						NO C.O. or Unpowered C.O.		w/PWRD C.O.		
						NO P.E.	w/ P.E. (pwrd fr/unit)	NO P.E.	w/ P.E. (pwrd fr/unit)	
558J-16D (2-Circuit / 2-Stage Cooling)	208/230-3-60	STD	291A00	16.5	12.4/15.2	049	049	049	049	
			294A00	33.5	25.2/30.8	049	049	049	049	
			288A00,294A00	43.5	32.7/40.0	051	051	051	051	
			291A00,294A00	50.0	37.6/45.9	051	051	051	051	
			294A00,294A00	67.0	50.3/61.5	053	053	053	053	
		MED	291A00	16.5	12.4/15.2	049	049	049	049	
			294A00	33.5	25.2/30.8	049	049	049	049	
			288A00,294A00	43.5	32.7/40.0	051	051	051	051	
			291A00,294A00	50.0	37.6/45.9	051	051	051	051	
			294A00,294A00	67.0	50.3/61.5	053	053	053	053	
		HIGH	291A00	16.5	12.4/15.2	049	049	049	049	
			294A00	33.5	25.2/30.8	049	049	049	049	
			288A00,294A00	43.5	32.7/40.0	051	051	051	051	
			291A00,294A00	50.0	37.6/45.9	051	051	051	051	
			294A00,294A00	67.0	50.3/61.5	053	053	053	053	
		460-3-60	STD	292A00	16.5	15.2	—	—	—	—
				295A00	33.5	30.8	047	047	047	050
				289A00,295A00	43.5	40.0	050	050	050	050
	292A00,295A00			50.0	45.9	050	050	050	050	
	295A00,295A00			67.0	61.5	050	050	050	050	
	MED		292A00	16.5	15.2	—	—	—	—	
			295A00	33.5	30.8	047	047	047	050	
			289A00,295A00	43.5	40.0	050	050	050	050	
			292A00,295A00	50.0	45.9	050	050	050	050	
			295A00,295A00	67.0	61.5	050	050	050	050	
	HIGH		292A00	16.5	15.2	—	—	—	—	
			295A00	33.5	30.8	050	050	050	050	
			289A00,295A00	43.5	40.0	050	050	050	050	
			292A00,295A00	50.0	45.9	050	050	050	050	
			295A00,295A00	67.0	61.5	050	050	050	050	
	575-3-60		STD	293A00	16.5	15.2	—	—	—	—
				296A00	33.5	30.8	047	047	047	047
				290A00,296A00	43.5	40.0	047	050	047	050
		293A00,296A00		50.0	45.9	047	047	047	047	
		296A00,296A00		67.0	61.5	050	050	050	050	
		MED	293A00	16.5	15.2	—	—	—	—	
			296A00	33.5	30.8	047	047	047	047	
			290A00,296A00	43.5	40.0	047	050	047	050	
			293A00,296A00	50.0	45.9	047	047	047	047	
			296A00,296A00	67.0	61.5	050	050	050	050	
		HIGH	293A00	16.5	15.2	—	—	—	—	
			296A00	33.5	30.8	047	047	047	047	
			290A00,296A00	43.5	40.0	050	050	050	050	
			293A00,296A00	50.0	45.9	050	050	047	050	
			296A00,296A00	67.0	61.5	050	050	050	050	

LEGEND

- APP PWR — 208 / 230V / 460V / 575V
- C.O. — Convenience outlet
- FLA — Full load amps
- IFM — Indoor fan motor
- NOM PWR — 240V / 480V / 600V
- P.E. — Power exhaust
- PWRD — Powered convenience outlet
- UNPWRD — Unpowered convenience outlet

**SINGLE SPEED INDOOR FAN MOTOR
WITH FACTORY INSTALLED NON-FUSED DISCONNECT**

UNIT SIZE	NOM. V-PH-HZ	IFM TYPE	ELECTRIC HEATER PART NUMBER CRHEATERXXXXXX	NOM PWR (kW)	APP PWR (kW)	SINGLE POINT KIT PART NUMBER CRSINGLEXXA00			
						NO C.O. or Unpowered C.O.		w/PWRD C.O.	
						NO P.E.	w/ P.E. (pwrd fr/unit)	NO P.E.	w/ P.E. (pwrd fr/unit)
558J-16D (2-Circuit / 2-Stage Cooling)	208/230-3-60	STD	291A00	16.5	12.4/15.2	049	049	049	049
			294A00	33.5	25.2/30.8	049	049	049	049
			288A00,294A00	43.5	32.7/40.0	051	051	051	051
			291A00,294A00	50.0	37.6/45.9	051	051	051	051
			294A00,294A00	67.0	50.3/61.5	053	053	053	053
		MED	291A00	16.5	12.4/15.2	049	049	049	049
			294A00	33.5	25.2/30.8	049	049	049	049
			288A00,294A00	43.5	32.7/40.0	051	051	051	051
			291A00,294A00	50.0	37.6/45.9	051	051	051	051
			294A00,294A00	67.0	50.3/61.5	053	053	053	053
		HIGH	291A00	16.5	12.4/15.2	049	049	049	049
			294A00	33.5	25.2/30.8	049	049	049	049
			288A00,294A00	43.5	32.7/40.0	051	051	051	051
			291A00,294A00	50.0	37.6/45.9	051	051	051	051
			294A00,294A00	67.0	50.3/61.5	053	053	053	053
	460-3-60	STD	292A00	16.5	15.2	—	—	—	—
			295A00	33.5	30.8	047	047	047	050
			289A00,295A00	43.5	40.0	050	050	050	050
			292A00,295A00	50.0	45.9	050	050	050	050
			295A00,295A00	67.0	61.5	050	050	050	050
		MED	292A00	16.5	15.2	—	—	—	—
			295A00	33.5	30.8	047	047	047	050
			289A00,295A00	43.5	40.0	050	050	050	050
			292A00,295A00	50.0	45.9	050	050	050	050
			295A00,295A00	67.0	61.5	050	050	050	050
		HIGH	292A00	16.5	15.2	—	—	—	—
			295A00	33.5	30.8	050	050	050	050
			289A00,295A00	43.5	40.0	050	050	050	050
			292A00,295A00	50.0	45.9	050	050	050	050
			295A00,295A00	67.0	61.5	050	050	050	050
	575-3-60	STD	293A00	16.5	15.2	—	—	—	—
			296A00	33.5	30.8	047	047	047	047
			290A00,296A00	43.5	40.0	047	050	047	050
			293A00,296A00	50.0	45.9	047	047	047	047
			296A00,296A00	67.0	61.5	050	050	050	050
		MED	293A00	16.5	15.2	—	—	—	—
			296A00	33.5	30.8	047	047	047	047
			290A00,296A00	43.5	40.0	047	050	047	050
			293A00,296A00	50.0	45.9	047	047	047	047
			296A00,296A00	67.0	61.5	050	050	050	050
		HIGH	293A00	16.5	15.2	—	—	—	—
			296A00	33.5	30.8	047	047	047	047
			290A00,296A00	43.5	40.0	050	050	050	050
			293A00,296A00	50.0	45.9	050	050	047	050
			296A00,296A00	67.0	61.5	050	050	050	050

LEGEND

- APP PWR — 208 / 230V / 460V / 575V
- C.O. — Convenience outlet
- FLA — Full load amps
- IFM — Indoor fan motor
- NOM PWR — 240V / 480V / 600V
- P.E. — Power exhaust
- PWRD — Powered convenience outlet
- UNPWRD — Unpowered convenience outlet

ELECTRICAL DATA (CONT)

2-SPEED INDOOR FAN MOTOR WITH OR WITHOUT FACTORY INSTALLED NON-FUSED DISCONNECT

UNIT SIZE	NOM. V-PH-HZ	IFM TYPE	ELECTRIC HEATER PART NUMBER CRHEATERXXXXXX	NOM PWR (kW)	APP PWR (kW)	SINGLE POINT KIT PART NUMBER CRSINGLEXXXXA00			
						NO C.O. or Unpowered C.O.		w/PWRD C.O.	
						NO P.E.	w/ P.E. (pwrd fr/unit)	NO P.E.	w/ P.E. (pwrd fr/unit)
558-J-16D (2-Circuit / 2-Stage Cooling)	208/230-3-60	STD	291A00	16.5	12.4/15.2	049	049	049	049
			294A00	33.5	25.2/30.8	049	049	049	049
			288A00,294A00	43.5	32.7/40.0	051	051	051	051
			291A00,294A00	50.0	37.6/45.9	051	051	051	051
			294A00,294A00	67.0	50.3/61.5	053	053	053	053
		MED	291A00	16.5	12.4/15.2	049	049	049	049
			294A00	33.5	25.2/30.8	049	049	049	049
			288A00,294A00	43.5	32.7/40.0	051	051	051	051
			291A00,294A00	50.0	37.6/45.9	051	051	051	051
			294A00,294A00	67.0	50.3/61.5	053	053	053	053
		HIGH	291A00	16.5	12.4/15.2	049	049	049	049
			294A00	33.5	25.2/30.8	049	049	049	049
			288A00,294A00	43.5	32.7/40.0	051	051	051	051
			291A00,294A00	50.0	37.6/45.9	051	051	051	051
			294A00,294A00	67.0	50.3/61.5	053	053	053	053
	460-3-60	STD	292A00	16.5	15.2	—	—	—	—
			295A00	33.5	30.8	047	047	047	050
			289A00,295A00	43.5	40.0	050	050	050	050
			292A00,295A00	50.0	45.9	050	050	050	050
			295A00,295A00	67.0	61.5	050	050	050	050
		MED	292A00	16.5	15.2	—	—	—	—
			295A00	33.5	30.8	047	047	047	050
			289A00,295A00	43.5	40.0	050	050	050	050
			292A00,295A00	50.0	45.9	050	050	050	050
			295A00,295A00	67.0	61.5	050	050	050	050
		HIGH	292A00	16.5	15.2	—	—	—	—
			295A00	33.5	30.8	050	050	050	050
			289A00,295A00	43.5	40.0	050	050	050	050
			292A00,295A00	50.0	45.9	050	050	050	050
			295A00,295A00	67.0	61.5	050	050	050	050
	575-3-60	STD	293A00	16.5	15.2	—	—	—	—
			296A00	33.5	30.8	047	047	047	047
			290A00,296A00	43.5	40.0	047	050	050	050
			293A00,296A00	50.0	45.9	047	047	047	050
			296A00,296A00	67.0	61.5	050	050	050	050
		MED	293A00	16.5	15.2	—	—	—	—
296A00			33.5	30.8	047	047	047	047	
290A00,296A00			43.5	40.0	047	050	050	050	
293A00,296A00			50.0	45.9	047	047	047	050	
296A00,296A00			67.0	61.5	050	050	050	050	
HIGH		293A00	16.5	15.2	—	—	—	—	
		296A00	33.5	30.8	047	047	047	047	
		290A00,296A00	43.5	40.0	050	050	050	050	
		293A00,296A00	50.0	45.9	050	050	050	050	
		296A00,296A00	67.0	61.5	050	050	050	050	
		296A00,296A00	67.0	61.5	050	050	050	050	

LEGEND

APP PWR — 208 / 230V / 460V / 575V
C.O. — Convenience outlet
FLA — Full load amps
IFM — Indoor fan motor
NOM PWR — 240V / 480V / 600V
P.E. — Power exhaust
PWRD — Powered convenience outlet
UNPWRD — Unpowered convenience outlet

**UNIT WIRE/FUSE OR HACR BREAKER SIZING DATA -
1-SPEED INDOOR FAN MOTOR, 6-15 TONS**

SIZE/STAGE	NOM. V-PH-Hz	IFM TYPE	ELECTRIC HEATER			NO CONVENIENCE OUTLET (C.O.) or UNPWR C.O.						w/ PWRD C.O.									
			CRHEATER ***A00	Nom (kW)	FLA	NO Power Exhaust (P.E.)			w/ P.E. (pwrd fr/ unit)			NO P.E.			w/ P.E. (pwrd fr/ unit)						
						MCA	Fuse or Hacr Brkr	DISC. SIZE		MCA	Fuse or Hacr Brkr	DISC. SIZE		MCA	Fuse or Hacr Brkr	DISC. SIZE		MCA	Fuse or Hacr Brkr	DISC. SIZE	
								FLA	LRA			FLA	LRA			FLA	LRA			FLA	LRA
558J-07A (1-Circuit / 1-Stage Cool)	208/230-3-60	STD	NONE	-	-	32	50	30	170	34	50	32	172	36	50	36	175	38	50	38	177
			102A	4.9/6.5	13.6/15.6	32/32	50/50	30/30	170/170	34/34	50/50	32/32	172/172	36/36	50/50	36/36	175/175	38/38	50/50	38/38	177/177
			104B	7.9/10.5	21.9/25.3	34/39	50/50	31/35	170/170	37/41	50/50	33/37	172/172	40/45	50/50	37/41	175/175	43/47	50/50	39/43	177/177
			105A	12.0/16.0	33.4/38.5	49/55	50/60	44/50	170/170	51/57	60/60	47/52	172/172	55/61	60/70	50/56	175/175	57/63	60/70	52/58	177/177
			104B+104B	15.8/21.0	43.8/50.5	62/70	70/70	56/64	170/170	64/72	70/80	59/66	172/172	68/76	70/80	62/70	175/175	70/78	70/80	64/72	177/177
			104B+105A	19.9/26.5	55.2/63.8	76/87	80/90	69/79	170/170	78/89	80/90	72/82	172/172	82/93	90/100	75/85	175/175	84/95	90/100	77/87	177/177
		MED	NONE	-	-	35/35	50/50	34/34	212	37/37	50/50	36/36	214	40/40	50/50	39/39	217	42/41	60/60	42/42	219
			102A	4.9/6.5	13.6/15.6	35/35	50/50	34/34	212/212	37/37	50/50	36/36	214/214	40/40	50/50	39/39	217/217	42/41	60/60	42/42	219/219
			104B	7.9/10.5	21.9/25.3	38/42	50/50	35/39	212/212	41/45	50/50	37/41	214/214	44/48	50/50	40/44	217/217	47/51	60/60	43/46	219/219
			105A	12.0/16.0	33.4/38.5	53/59	60/60	48/54	212/212	55/61	60/70	50/56	214/214	59/65	60/70	54/59	217/217	61/67	70/70	56/62	219/219
			104B+104B	15.8/21.0	43.8/50.5	66/74	70/80	60/68	212/212	68/76	70/80	62/70	214/214	72/80	80/80	66/73	217/217	74/82	80/90	68/75	219/219
			104B+105A	19.9/26.5	55.2/63.8	80/91	80/100	73/83	212/212	82/93	90/100	75/85	214/214	86/97	90/100	79/88	217/217	88/99	90/100	81/91	219/219
		HIGH	NONE	-	-	37	50	36	226	39	50	39	228	42	60	42	231	44	60	44	233
			102A	4.9/6.5	13.6/15.6	37/37	50/50	36/36	226/226	39/39	50/50	39/39	228/228	42/42	60/60	42/42	231/231	44/44	60/60	44/44	233/233
			104B	7.9/10.5	21.9/25.3	41/45	50/50	37/41	226/226	43/48	50/50	40/43	228/228	47/51	60/60	43/47	231/231	49/54	60/60	45/49	233/233
			105A	12.0/16.0	33.4/38.5	55/62	60/70	51/56	226/226	58/64	60/70	53/59	228/228	61/68	70/70	56/62	231/231	64/70	70/70	58/64	233/233
			104B+104B	15.8/21.0	43.8/50.5	68/77	70/80	63/70	226/226	71/79	80/80	65/72	228/228	74/83	80/90	68/76	231/231	77/85	80/90	70/78	233/233
			104B+105A	19.9/26.5	55.2/63.8	83/93	90/100	76/86	226/226	85/96	90/100	78/88	228/228	89/99	90/100	81/91	231/231	91/102	100/110	83/93	233/233
	460-3-60	STD	NONE	-	-	14	20	13	83	15	20	14	84	16	20	16	85	17	25	17	86
			106A	6.0	7.2	14	20	13	83	15	20	14	84	16	20	16	85	17	25	17	86
			108A	11.5	13.8	21	25	19	83	22	25	20	84	24	25	21	85	25	25	23	86
			109A	14.0	16.8	25	25	22	83	26	30	23	84	27	30	25	85	29	30	26	86
			108A+108A	23.0	27.7	38	40	35	83	40	40	36	84	41	45	37	85	42	45	39	86
			108A+109A	25.5	30.7	42	45	38	83	43	45	39	84	45	45	41	85	46	50	42	86
MED		NONE	-	-	16	20	15	104	17	20	16	105	18	25	18	106	19	25	19	107	
		106A	6.0	7.2	16	20	15	104	17	20	16	105	18	25	18	106	19	25	19	107	
		108A	11.5	13.8	23	25	21	104	24	25	22	105	26	30	23	106	27	30	24	107	
		109A	14.0	16.8	27	30	24	104	28	30	25	105	29	30	27	106	31	35	28	107	
		108A+108A	23.0	27.7	40	40	37	104	42	45	38	105	43	45	39	106	44	45	40	107	
		108A+109A	25.5	30.7	44	45	40	104	45	45	41	105	47	50	43	106	48	50	44	107	
HIGH		NONE	-	-	17	20	16	111	18	25	18	112	19	25	19	113	20	25	20	114	
		106A	6.0	7.2	17	20	16	111	18	25	18	112	19	25	19	113	20	25	20	114	
		108A	11.5	13.8	24	25	22	111	26	30	23	112	27	30	24	113	28	30	26	114	
		109A	14.0	16.8	28	30	25	111	29	30	27	112	31	35	28	113	32	35	29	114	
		108A+108A	23.0	27.7	42	45	38	111	43	45	39	112	44	45	40	113	46	50	42	114	
		108A+109A	25.5	30.7	45	50	41	111	47	50	43	112	48	50	44	113	49	50	45	114	
575-3-60	STD	NONE	-	-	11	15	11	68	13	15	13	70	13	15	13	70	15	20	15	72	
	MED	NONE	-	-	12	15	12	79	14	20	14	81	14	15	13	81	16	20	16	83	
	HIGH	NONE	-	-	12	15	12	79	14	20	14	81	14	15	13	81	16	20	16	83	

See Legend and Notes on page 54.

ELECTRICAL DATA (CONT)

UNIT WIRE/FUSE OR HACR BREAKER SIZING DATA - 1-SPEED INDOOR FAN MOTOR, 6-15 TONS (CONT)

SIZE/STAGE	NOM. V-FPH-Hz	IFM TYPE	ELECTRIC HEATER			NO CONVENIENCE OUTLET (C.O.) or UNPWR C.O.								w/ PWRD C.O.							
			CRHEATER ***A00	Nom (kW)	FLA	NO Power Exhaust (P.E.)				w/ P.E. (pwrd fr/ unit)				NO P.E.				w/ P.E. (pwrd fr/ unit)			
						MCA	Fuse or Hacr Brkr	DISC. SIZE		MCA	Fuse or Hacr Brkr	DISC. SIZE		MCA	Fuse or Hacr Brkr	DISC. SIZE		MCA	Fuse or Hacr Brkr	DISC. SIZE	
								FLA	LRA			FLA	LRA			FLA	LRA			FLA	LRA
556J-08D (2-Circuit / 2-Stage Cooling)	208/230-3-60	STD	NONE	-	-	39/39	50/50	41/40	210	43/43	50/50	45/45	214	44/44	50/50	46/46	215	48/48	60/60	51/50	219
			117A	7.8/10.4	21.7/25.0	39/39	50/50	41/40	210/210	43/43	50/50	45/45	214/214	44/44	50/50	46/46	215/215	48/49	60/60	51/50	219/219
			110A	12.0/16.0	33.4/38.5	49/55	50/60	44/50	210/210	53/59	60/60	49/54	214/214	55/61	60/70	50/55	215/215	59/65	60/70	54/60	219/219
			111A	18.6/24.8	51.7/59.7	72/81	80/90	65/74	210/210	76/86	80/90	70/79	214/214	78/87	80/90	71/80	215/215	82/92	90/100	75/84	219/219
			112A	24.0/32.0	66.7/77.0	90/103	90/110	83/94	210/210	95/108	100/110	87/99	214/214	96/109	100/110	88/100	215/215	101/114	110/125	93/104	219/219
			112A+117A	31.8/42.4	88.4/102.0	117/134	125/150	108/123	210/210	122/139	125/150	112/127	214/214	123/140	125/150	113/128	215/215	128/145	150/150	118/133	219/219
		MED	NONE	-	-	42/42	50/50	44/44	246	46/46	50/50	49/49	250	47/47	60/60	50/50	251	51/51	60/60	54/54	255
			117A	7.8/10.4	21.7/25.0	42/42	50/50	44/44	246/246	46/47	50/50	49/49	250/250	47/48	60/60	50/50	251/251	51/53	60/60	54/54	255/255
			110A	12.0/16.0	33.4/38.5	53/59	60/60	48/54	246/246	57/64	60/70	52/58	250/250	59/65	60/70	54/59	251/251	63/70	70/70	58/64	255/255
			111A	18.6/24.8	51.7/59.7	76/85	80/90	69/78	246/246	80/90	80/90	73/83	250/250	82/91	90/100	75/84	251/251	86/96	90/100	79/88	255/255
			112A	24.0/32.0	66.7/77.0	94/107	100/110	86/98	246/246	99/112	100/125	91/102	250/250	100/113	100/125	92/104	251/251	105/118	110/125	96/108	255/255
			112A+117A	31.8/42.4	88.4/102.0	121/138	125/150	111/127	246/246	126/143	150/150	116/131	250/250	127/144	150/150	117/132	251/251	132/149	150/150	121/137	255/255
	HIGH	NONE	-	-	48/47	60/50	50/49	262	51/51	60/60	55/54	266	52/52	60/60	56/55	267	56/55	60/60	60/59	271	
		117A	7.8/10.4	21.7/25.0	48/48	60/50	50/49	262/262	51/52	60/60	55/54	266/266	52/54	60/60	56/55	267/267	56/58	60/60	60/59	271/271	
		110A	12.0/16.0	33.4/38.5	59/64	60/70	54/59	262/262	64/69	70/70	58/63	266/266	65/70	70/70	60/64	267/267	70/75	70/80	64/69	271/271	
		111A	18.6/24.8	51.7/59.7	82/91	90/100	75/83	262/262	87/96	90/100	79/88	266/266	88/97	90/100	81/89	267/267	93/102	100/110	85/93	271/271	
		112A	24.0/32.0	66.7/77.0	101/113	110/125	92/103	262/262	106/117	110/125	97/108	266/266	107/119	110/125	98/109	267/267	112/123	125/125	102/113	271/271	
		112A+117A	31.8/42.4	88.4/102.0	128/144	150/150	117/132	262/262	133/149	150/150	122/136	266/266	134/150	150/150	123/137	267/267	139/155	150/175	127/142	271/271	
	460-3-60	STD	NONE	-	-	18	20	19	104	20	25	21	106	20	25	21	106	22	25	23	108
			116B	13.9	16.7	24	25	22	104	27	30	24	106	27	30	25	106	29	30	27	108
			113B	16.5	19.8	28	30	26	104	31	35	28	106	31	35	28	106	33	35	30	108
			114B	27.8	33.4	45	45	41	104	48	50	43	106	48	50	44	106	50	50	46	108
			115B	33.0	39.7	53	60	49	104	55	60	51	106	56	60	51	106	58	60	53	108
			128B	41.7	50.2	66	70	61	104	69	70	63	106	69	70	63	106	71	80	65	108
MED		NONE	-	-	20	25	21	122	22	25	23	124	22	25	23	124	24	30	25	126	
		116B	13.9	16.7	27	30	24	122	29	30	26	124	29	30	27	124	32	35	29	126	
		113B	16.5	19.8	30	30	28	122	33	35	30	124	33	35	30	124	35	40	32	126	
		114B	27.8	33.4	47	50	43	122	50	50	45	124	50	50	46	124	52	60	48	126	
		115B	33.0	39.7	55	60	50	122	58	60	53	124	58	60	53	124	60	60	55	126	
		128B	41.7	50.2	68	70	63	122	71	80	65	124	71	80	65	124	73	80	67	126	
HIGH		NONE	-	-	22	25	23	130	24	30	25	132	24	30	26	132	26	30	28	134	
		116B	13.9	16.7	29	30	27	130	32	35	29	132	32	35	29	132	34	35	31	134	
		113B	16.5	19.8	33	35	30	130	35	35	32	132	36	40	33	132	38	40	35	134	
		114B	27.8	33.4	50	50	46	130	52	60	48	132	53	60	48	132	55	60	50	134	
		115B	33.0	39.7	58	60	53	130	60	60	55	132	61	70	56	132	63	70	58	134	
		128B	41.7	50.2	71	80	65	130	73	80	67	132	74	80	68	132	76	80	70	134	
575-3-60	STD	NONE	-	-	14	15	14	85	18	20	19	89	16	20	16	87	19	25	21	91	
		118A	18.0	17.3	26	30	23	85	30	30	27	89	28	30	25	87	32	35	29	91	
		119A	36.0	34.6	47	50	43	85	52	60	47	89	49	50	45	87	54	60	49	91	
	MED	NONE	-	-	14	15	14	92	18	20	19	96	16	20	16	94	19	25	21	98	
		118A	18.0	17.3	26	30	23	92	30	30	27	96	28	30	25	94	32	35	29	98	
		119A	36.0	34.6	47	50	43	92	52	60	47	96	49	50	45	94	54	60	49	98	
	HIGH	NONE	-	-	17	20	17	106	21	25	22	110	19	20	19	108	23	25	24	112	
		118A	18.0	17.3	29	30	26	106	34	35	31	110	31	35	28	108	36	40	33	112	
		119A	36.0	34.6	51	60	46	106	55	60	51	110	53	60	48	108	58	60	53	112	

See Legend and Notes on page 54.

**UNIT WIRE/FUSE OR HACR BREAKER SIZING DATA -
1-SPEED INDOOR FAN MOTOR, 6-15 TONS (CONT)**

SIZE/STAGE	NOM. V-PH-Hz	IFM TYPE	ELECTRIC HEATER			NO CONVENIENCE OUTLET (C.O.) or UNPWR C.O.						w/ PWRD C.O.									
			CRHEATER ***A00	Nom (kW)	FLA	NO Power Exhaust (P.E.)			w/ P.E. (pwrd fr/ unit)			NO P.E.			w/ P.E. (pwrd fr/ unit)						
						MCA	Fuse or Hacr Brkr	DISC. SIZE		MCA	Fuse or Hacr Brkr	DISC. SIZE		MCA	Fuse or Hacr Brkr	DISC. SIZE		MCA	Fuse or Hacr Brkr	DISC. SIZE	
								FLA	LRA			FLA	LRA			FLA	LRA			FLA	LRA
558J-08N (1-Circuit / 2-Stage Cooling)	208/230-3-60	STD	NONE	-	-	42/42	60/60	40/40	208	46/46	60/60	45/44	212	47/47	60/60	46/45	213	51/50	60/60	50/50	217/217
			117A	7.8/10.4	21.7/25.0	42/42	60/60	40/40	208/208	46/46	60/60	45/44	212/212	47/47	60/60	46/45	213/213	51/50	60/60	50/50	217/217
			110A	12.0/16.0	33.4/38.5	49/55	60/60	44/50	208/208	53/59	60/60	49/54	212/212	55/61	60/70	50/55	213/213	59/65	60/70	54/60	217/217
			111A	18.6/24.8	51.7/59.7	72/81	80/90	65/74	208/208	76/86	80/90	70/79	212/212	78/87	80/90	71/80	213/213	82/92	90/100	75/84	217/217
			112A	24.0/32.0	66.7/77.0	90/103	90/110	83/94	208/208	95/108	100/110	87/99	212/212	96/109	100/110	88/100	213/213	101/114	110/125	93/104	217/217
			112A+117A	31.8/42.4	88.4/102.0	117/134	125/150	108/123	208/208	122/139	125/150	112/127	212/212	123/140	125/150	113/128	213/213	128/145	150/150	118/133	217/217
		MED	NONE	-	-	45/45	60/60	44/44	244	49/49	60/60	48/48	248	50/50	60/60	49/49	249	54/54	80/80	54/54	253
			117A	7.8/10.4	21.7/25.0	45/45	60/60	44/44	244/244	49/49	60/60	48/48	248/248	50/50	60/60	49/49	249/249	54/54	80/80	54/54	253/253
			110A	12.0/16.0	33.4/38.5	53/59	60/60	48/54	244/244	57/64	60/70	52/58	248/248	59/65	60/70	54/59	249/249	63/70	80/80	58/64	253/253
			111A	18.6/24.8	51.7/59.7	76/85	80/90	69/78	244/244	80/90	80/90	73/83	248/248	82/91	90/100	75/84	249/249	86/96	90/100	79/88	253/253
			112A	24.0/32.0	66.7/77.0	94/107	100/110	86/98	244/244	99/112	100/125	91/102	248/248	100/113	100/125	92/104	249/249	105/118	110/125	96/108	253/253
			112A+117A	31.8/42.4	88.4/102.0	121/138	125/150	111/127	244/244	126/143	150/150	116/131	248/248	127/144	150/150	117/132	249/249	132/149	150/150	121/137	253/253
	HIGH	NONE	-	-	51/50	60/60	50/49	260	54/53	80/60	54/53	264	55/54	80/80	55/54	265	59/58	80/80	60/59	269	
		117A	7.8/10.4	21.7/25.0	51/50	60/60	50/49	260/260	54/53	80/60	54/53	264/264	55/54	80/80	55/54	265/265	59/58	80/80	60/59	269/269	
		110A	12.0/16.0	33.4/38.5	59/64	60/70	54/59	260/260	64/69	80/70	58/63	264/264	65/70	80/80	60/64	265/265	70/75	80/80	64/69	269/269	
		111A	18.6/24.8	51.7/59.7	82/91	90/100	75/83	260/260	87/96	90/100	79/88	264/264	88/97	90/100	81/89	265/265	93/102	100/110	85/93	269/269	
		112A	24.0/32.0	66.7/77.0	101/113	110/125	92/103	260/260	106/117	110/125	97/108	264/264	107/119	110/125	98/109	265/265	112/123	125/125	102/113	269/269	
		112A+117A	31.8/42.4	88.4/102.0	128/144	150/150	117/132	260/260	133/149	150/150	122/136	264/264	134/150	150/150	123/137	265/265	139/155	150/175	127/142	269/269	
	460-3-60	STD	NONE	-	-	20	30	19	116	21	30	21	118	22	30	21	118	24	30	23	120
			116B	13.9	16.7	24	30	22	116	27	30	24	118	27	30	25	118	29	30	27	120
			113B	16.5	19.8	28	30	26	116	31	35	28	118	31	35	28	118	33	35	30	120
			114B	27.8	33.4	45	45	41	116	48	50	43	118	48	50	44	118	50	50	46	120
			115B	33.0	39.7	53	60	49	116	55	60	51	118	56	60	51	118	58	60	53	120
			128B	41.7	50.2	66	70	61	116	69	70	63	118	69	70	63	118	71	80	65	120
MED		NONE	-	-	21	30	20	134	23	30	23	136	23	30	23	136	25	30	25	138	
		116B	13.9	16.7	27	30	24	134	29	30	26	136	29	30	27	136	32	35	29	138	
		113B	16.5	19.8	30	30	28	134	33	35	30	136	33	35	30	136	35	40	32	138	
		114B	27.8	33.4	47	50	43	134	50	50	45	136	50	50	46	136	52	60	48	138	
		115B	33.0	39.7	55	60	50	134	58	60	53	136	58	60	53	136	60	60	55	138	
		128B	41.7	50.2	68	70	63	134	71	80	65	136	71	80	65	136	73	80	67	138	
HIGH		NONE	-	-	23	30	23	142	25	30	25	144	26	30	26	144	27	35	28	146	
		116B	13.9	16.7	29	30	27	142	32	35	29	144	32	35	29	144	34	35	31	146	
		113B	16.5	19.8	33	35	30	142	35	35	32	144	36	40	33	144	38	40	35	146	
		114B	27.8	33.4	50	50	46	142	52	60	48	144	53	60	48	144	55	60	50	146	
		115B	33.0	39.7	58	60	53	142	60	60	55	144	61	70	56	144	63	70	58	146	
		128B	41.7	50.2	71	80	65	142	73	80	67	144	74	80	68	144	76	80	70	146	

See Legend and Notes on page 54.

ELECTRICAL DATA (CONT)

UNIT WIRE/FUSE OR HACR BREAKER SIZING DATA - 1-SPEED INDOOR FAN MOTOR, 6-15 TONS (CONT)

SIZE/STAGE	NOM. V-FPH-Hz	IFM TYPE	ELECTRIC HEATER			NO CONVENIENCE OUTLET (C.O.) or UNPWR C.O.								w/ PWRD C.O.							
			CRHEATER ***A00	Nom (kW)	FLA	NO Power Exhaust (P.E.)				w/ P.E. (pwrd fr/ unit)				NO P.E.				w/ P.E. (pwrd fr/ unit)			
						MCA	Fuse or Hacr Brkr	DISC. SIZE		MCA	Fuse or Hacr Brkr	DISC. SIZE		MCA	Fuse or Hacr Brkr	DISC. SIZE		MCA	Fuse or Hacr Brkr	DISC. SIZE	
								FLA	LRA			FLA	LRA			FLA	LRA			FLA	LRA
558J-99D (2-Circuit / 2-Stage Cooling)	208/230-3-60	STD	NONE	-	-	40	50	42	208	44	50	46	212	45	50	47	213	49	60	52	217
			117A	7.8/10.4	21.7/25.0	40/40	50/50	42/42	208/208	44/44	50/50	46/46	212/212	45/45	50/50	47/47	213/213	49/49	60/60	52/52	217/217
			110A	12.0/16.0	33.4/38.5	49/55	50/60	44/50	208/208	53/60	60/60	49/55	212/212	55/61	60/70	50/56	213/213	59/66	60/70	54/60	217/217
			111A	18.6/24.8	51.7/59.7	72/82	80/90	65/75	208/208	76/86	80/90	70/79	212/212	78/88	80/90	71/80	213/213	82/92	90/100	75/85	217/217
			112A	24.0/32.0	66.7/77.0	90/103	90/110	83/95	208/208	95/108	100/110	87/99	212/212	96/109	100/110	88/100	213/213	101/114	110/125	93/104	217/217
			112A+117A	31.8/42.4	88.4/102.0	117/134	125/150	108/123	208/208	122/139	125/150	112/128	212/212	123/140	125/150	113/129	213/213	128/145	150/150	118/133	217/217
		MED	NONE	-	-	42/42	50/50	44/44	246	46/46	60/50	48/48	250	47/47	60/60	49/49	251	51/51	60/60	54/53	255
			117A	7.8/10.4	21.7/25.0	42/42	50/50	44/44	246/246	46/46	60/50	48/48	250/250	47/47	60/60	49/49	251/251	51/51	60/60	54/53	255/255
			110A	12.0/16.0	33.4/38.5	51/57	60/60	46/52	246/246	56/62	60/70	51/56	250/250	57/63	60/70	52/58	251/251	62/68	70/70	56/62	255/255
			111A	18.6/24.8	51.7/59.7	74/83	80/90	67/76	246/246	78/88	80/90	72/81	250/250	80/89	80/90	73/82	251/251	84/94	90/100	77/86	255/255
			112A	24.0/32.0	66.7/77.0	92/105	100/110	85/96	246/246	97/110	100/110	89/101	250/250	98/111	100/125	90/102	251/251	103/116	110/125	95/106	255/255
			112A+117A	31.8/42.4	88.4/102.0	120/136	125/150	110/125	246/246	124/141	125/150	114/129	250/250	126/142	150/150	115/131	251/251	130/147	150/150	119/135	255/255
	HIGH	NONE	-	-	46	50	48	275	50	60	52	279	51	60	54	280	54	60	58	284	
		117A	7.8/10.4	21.7/25.0	46/46	50/50	48/48	275/275	50/50	60/60	52/52	279/279	51/51	60/60	54/54	280/280	54/56	60/60	58/58	284/284	
		110A	12.0/16.0	33.4/38.5	55/62	60/70	51/56	275/275	60/67	60/70	55/61	279/279	61/68	70/70	56/62	280/280	66/73	70/80	60/66	284/284	
		111A	18.6/24.8	51.7/59.7	78/88	80/90	72/81	275/275	83/93	90/100	76/85	279/279	84/94	90/100	77/86	280/280	89/99	90/100	82/91	284/284	
		112A	24.0/32.0	66.7/77.0	97/110	100/110	89/101	275/275	102/115	110/125	93/105	279/279	103/116	110/125	94/106	280/280	108/121	110/125	99/111	284/284	
		112A+117A	31.8/42.4	88.4/102.0	124/141	125/150	114/129	275/275	129/146	150/150	118/134	279/279	130/147	150/150	119/135	280/280	135/152	150/175	124/139	284/284	
	460-3-60	STD	NONE	-	-	19	20	19	109	21	25	21	111	21	25	22	111	23	25	24	113
			116B	13.9	16.7	25	25	22	109	27	30	24	111	27	30	25	111	30	30	27	113
			113B	16.5	19.8	28	30	26	109	31	35	28	111	31	35	28	111	33	35	30	113
			114B	27.8	33.4	45	50	41	109	48	50	43	111	48	50	44	111	50	60	46	113
			115B	33.0	39.7	53	60	49	109	56	60	51	111	56	60	51	111	58	60	53	113
			128B	41.7	50.2	66	70	61	109	69	70	63	111	69	70	63	111	71	80	65	113
MED		NONE	-	-	20	25	20	128	21	25	22	130	22	25	23	130	24	25	25	132	
		116B	13.9	16.7	26	30	23	128	28	30	25	130	28	30	26	130	31	35	28	132	
		113B	16.5	19.8	29	30	27	128	32	35	29	130	32	35	29	130	34	35	31	132	
		114B	27.8	33.4	46	50	42	128	49	50	44	130	49	50	45	130	51	60	47	132	
		115B	33.0	39.7	54	60	50	128	57	60	52	130	57	60	52	130	59	60	54	132	
		128B	41.7	50.2	67	70	62	128	70	70	64	130	70	70	64	130	72	80	66	132	
HIGH		NONE	-	-	21	25	22	143	23	25	24	145	24	25	25	145	25	30	27	147	
		116B	13.9	16.7	28	30	25	143	30	30	27	145	31	35	28	145	33	35	30	147	
		113B	16.5	19.8	32	35	29	143	34	35	31	145	35	35	31	145	37	40	33	147	
		114B	27.8	33.4	49	50	45	143	51	60	47	145	52	60	47	145	54	60	49	147	
		115B	33.0	39.7	57	60	52	143	59	60	54	145	59	60	54	145	62	70	56	147	
		128B	41.7	50.2	70	70	64	143	72	80	66	145	73	80	66	145	75	80	68	147	
575-3-60	STD	NONE	-	-	16	20	16	85	19	25	20	89	17	20	18	87	21	25	22	91	
		118A	18.0	17.3	24	25	22	85	29	30	26	89	26	30	24	87	31	35	28	91	
		119A	36.0	34.6	46	50	42	85	50	60	46	89	48	50	44	87	53	60	48	91	
	MED	NONE	-	-	16	20	16	89	20	25	20	93	18	20	18	91	21	25	22	95	
		118A	18.0	17.3	25	25	22	89	29	30	27	93	27	30	24	91	31	35	29	95	
		119A	36.0	34.6	46	50	42	89	51	60	46	93	48	50	44	91	53	60	48	95	
	HIGH	NONE	-	-	17	20	17	100	21	25	21	104	18	20	19	102	22	25	23	106	
		118A	18.0	17.3	26	30	23	100	30	30	27	104	28	30	25	102	32	35	29	106	
		119A	36.0	34.6	47	50	43	100	52	60	47	104	49	50	45	102	54	60	49	106	

See Legend and Notes on page 54.

**UNIT WIRE/FUSE OR HACR BREAKER SIZING DATA -
1-SPEED INDOOR FAN MOTOR, 6-15 TONS (CONT)**

SIZE/STAGE	NOM. V-Ph-Hz	IFM TYPE	ELECTRIC HEATER			NO CONVENIENCE OUTLET (C.O.) or UNPWR C.O.								w/ PWRD C.O.							
			CRHEATER ***A00	Nom (kW)	FLA	NO Power Exhaust (P.E.)				w/ P.E. (pwrd fr/ unit)				NO P.E.				w/ P.E. (pwrd fr/ unit)			
						MCA	Fuse or Hacr Brkr	DISC. SIZE		MCA	Fuse or Hacr Brkr	DISC. SIZE		MCA	Fuse or Hacr Brkr	DISC. SIZE		MCA	Fuse or Hacr Brkr	DISC. SIZE	
								FLA	LRA			FLA	LRA			FLA	LRA			FLA	LRA
558J-09N (1-Circuit / 2-Stage Cooling)	208/230-3-Ø0	STD	NONE	-	-	45	60	43	250	48	60	47	254	49	60	48	255	53	80	52	259
			117A	7.8/10.4	21.7/25.0	45/45	60/60	43/43	250/250	48/48	60/60	47/47	254/254	49/49	60/60	48/48	255/255	53/53	80/80	52/52	259/259
			110A	12.0/16.0	33.4/38.5	49/55	60/60	44/50	250/250	53/60	60/60	49/55	254/254	55/61	60/70	50/56	255/255	59/66	80/80	54/60	259/259
			111A	18.6/24.8	51.7/59.7	72/82	80/90	65/75	250/250	76/86	80/90	70/79	254/254	78/88	80/90	71/80	255/255	82/92	90/100	75/85	259/259
			112A	24.0/32.0	66.7/77.0	90/103	90/110	83/95	250/250	95/108	100/110	87/99	254/254	96/109	100/110	88/100	255/255	101/114	110/125	93/104	259/259
			112A+117A	31.8/42.4	88.4/102.0	117/134	125/150	108/123	250/250	122/139	125/150	112/128	254/254	123/140	125/150	113/129	255/255	128/145	150/150	118/133	259/259
		MED	NONE	-	-	46/46	60/60	45/44	288	50/50	60/60	49/49	292	51/51	60/60	50/50	293	55/55	80/80	54/54	297
			117A	7.8/10.4	21.7/25.0	46/46	60/60	45/44	288/288	50/50	60/60	49/49	292/292	51/51	60/60	50/50	293/293	55/55	80/80	54/54	297/297
			110A	12.0/16.0	33.4/38.5	51/57	60/60	46/52	288/288	56/62	60/70	51/56	292/292	57/63	60/70	52/58	293/293	62/68	80/80	56/62	297/297
			111A	18.6/24.8	51.7/59.7	74/83	80/90	67/76	288/288	78/88	80/90	72/81	292/292	80/89	80/90	73/82	293/293	84/94	90/100	77/86	297/297
	112A		24.0/32.0	66.7/77.0	92/105	100/110	85/96	288/288	97/110	100/110	89/101	292/292	98/111	100/125	90/102	293/293	103/116	110/125	95/106	297/297	
	112A+117A		31.8/42.4	88.4/102.0	120/136	125/150	110/125	288/288	124/141	125/150	114/129	292/292	126/142	150/150	115/131	293/293	130/147	150/150	119/135	297/297	
	HIGH	NONE	-	-	50	60	49	317	54	80	53	321	55	80	54	322	59	80	59	326	
		117A	7.8/10.4	21.7/25.0	50/50	60/60	49/49	317/317	54/54	80/80	53/53	321/321	55/55	80/80	54/54	322/322	59/59	80/80	59/59	326/326	
		110A	12.0/16.0	33.4/38.5	55/62	60/70	51/56	317/317	60/67	80/80	55/61	321/321	61/68	80/80	56/62	322/322	66/73	80/80	60/66	326/326	
		111A	18.6/24.8	51.7/59.7	78/88	80/90	72/81	317/317	83/93	90/100	76/85	321/321	84/94	90/100	77/86	322/322	89/99	90/100	82/91	326/326	
		112A	24.0/32.0	66.7/77.0	97/110	100/110	89/101	317/317	102/115	110/125	93/105	321/321	103/116	110/125	94/106	322/322	108/121	110/125	99/111	326/326	
		112A+117A	31.8/42.4	88.4/102.0	124/141	125/150	114/129	317/317	129/146	150/150	118/134	321/321	130/147	150/150	119/135	322/322	135/152	150/175	124/139	326/326	
	460-3-Ø0	STD	NONE	-	-	20	30	19	113	22	30	21	115	22	30	22	115	24	30	24	117
			116B	13.9	16.7	25	30	22	113	27	30	24	115	27	30	25	115	30	30	27	117
113B			16.5	19.8	28	30	26	113	31	35	28	115	31	35	28	115	33	35	30	117	
114B			27.8	33.4	45	50	41	113	48	50	43	115	48	50	44	115	50	60	46	117	
115B			33.0	39.7	53	60	49	113	56	60	51	115	56	60	51	115	58	60	53	117	
128B			41.7	50.2	66	70	61	113	69	70	63	115	69	70	63	115	71	80	65	117	
MED		NONE	-	-	21	30	20	132	23	30	22	134	23	30	23	134	25	30	25	136	
		116B	13.9	16.7	26	30	23	132	28	30	25	134	28	30	26	134	31	35	28	136	
		113B	16.5	19.8	29	30	27	132	32	35	29	134	32	35	29	134	34	35	31	136	
		114B	27.8	33.4	46	50	42	132	49	50	44	134	49	50	45	134	51	60	47	136	
		115B	33.0	39.7	54	60	50	132	57	60	52	134	57	60	52	134	59	60	54	136	
		128B	41.7	50.2	67	70	62	132	70	70	64	134	70	70	64	134	72	80	66	136	
HIGH		NONE	-	-	23	30	22	147	25	30	24	149	25	30	25	149	27	30	27	151	
		116B	13.9	16.7	28	30	25	147	30	30	27	149	31	35	28	149	33	35	30	151	
		113B	16.5	19.8	32	35	29	147	34	35	31	149	35	35	31	149	37	40	33	151	
		114B	27.8	33.4	49	50	45	147	51	60	47	149	52	60	47	149	54	60	49	151	
		115B	33.0	39.7	57	60	52	147	59	60	54	149	59	60	54	149	62	70	56	151	
		128B	41.7	50.2	70	70	64	147	72	80	66	149	73	80	66	149	75	80	68	151	
575-3-Ø0	STD	NONE	-	-	15	20	14	81	19	25	19	85	17	25	16	83	21	30	21	87	
		118A	18.0	17.3	24	25	22	81	29	30	26	85	26	30	24	83	31	35	28	87	
		119A	36.0	34.6	46	50	42	81	50	60	46	85	48	50	44	83	53	60	48	87	
	MED	NONE	-	-	16	25	15	85	20	25	19	89	17	25	17	87	21	30	21	91	
		118A	18.0	17.3	25	25	22	85	29	30	27	89	27	30	24	87	31	35	29	91	
		119A	36.0	34.6	46	50	42	85	51	60	46	89	48	50	44	87	53	60	48	91	
	HIGH	NONE	-	-	17	25	16	96	20	25	20	100	18	25	18	98	22	30	22	102	
		118A	18.0	17.3	26	30	23	96	30	30	27	100	28	30	25	98	32	35	29	102	
		119A	36.0	34.6	47	50	43	96	52	60	47	100	49	50	45	98	54	60	49	102	

See Legend and Notes on page 54.

ELECTRICAL DATA (CONT)

UNIT WIRE/FUSE OR HACR BREAKER SIZING DATA - 1-SPEED INDOOR FAN MOTOR, 6-15 TONS (CONT)

SIZE/STAGE	NOM. V-Ph-Hz	IFM TYPE	ELECTRIC HEATER			NO CONVENIENCE OUTLET (C.O.) or UNPWR C.O.						w/ PWRD C.O.									
			CRHEATER ***A00	Nom (kW)	FLA	NO Power Exhaust (P.E.)			w/ P.E. (pwrdr fr/ unit)			NO P.E.				w/ P.E. (pwrdr fr/ unit)					
						MCA	Fuse or Hacr Brkr	DISC. SIZE		MCA	Fuse or Hacr Brkr	DISC. SIZE		MCA	Fuse or Hacr Brkr	DISC. SIZE		MCA	Fuse or Hacr Brkr	DISC. SIZE	
								FLA	LRA			FLA	LRA			FLA	LRA			FLA	LRA
208/230-3-60	STD	NONE	-	-	44	50	46	258	48	60	50	262	49	60	51	263	53	60	56	267	
		117A	7.8/10.4	21.7/25.0	44/44	50/50	46/46	258/258	48/48	60/60	50/50	262/262	49/49	60/60	51/51	263/263	53/53	60/60	56/56	267/267	
		110A	12.0/16.0	33.4/38.5	49/55	50/60	46/50	258/258	53/60	60/60	50/55	262/262	55/61	60/70	51/56	263/263	59/66	60/70	56/60	267/267	
		112A	24.0/32.0	66.7/77.0	90/103	90/110	83/95	258/258	95/108	100/110	87/99	262/262	96/109	100/110	88/100	263/263	101/114	110/125	93/104	267/267	
		112A+117A	31.8/42.4	88.4/102.0	117/134	125/150	108/123	258/258	122/139	125/150	112/128	262/262	123/140	125/150	113/129	263/263	128/145	150/150	118/133	267/267	
		112A+110A	37.6/50.0	104.2/120.3	137/127	150/150	126/144	258/258	142/132	150/150	130/149	262/262	143/133	150/150	131/150	263/263	148/138	150/150	136/154	267/267	
	MED	NONE	-	-	50	60	52	314	53	60	56	318	54	60	57	319	58	70	62	323	
		117A	7.8/10.4	21.7/25.0	50/50	60/60	52/52	314/314	53/53	60/60	56/56	318/318	54/54	60/60	57/57	319/319	58/58	70/70	62/62	323/323	
		110A	12.0/16.0	33.4/38.5	55/62	60/70	52/56	314/314	60/67	60/70	56/61	318/318	61/68	70/70	57/62	319/319	66/73	70/80	62/66	323/323	
		112A	24.0/32.0	66.7/77.0	97/110	100/110	89/101	314/314	102/115	110/125	93/105	318/318	103/116	110/125	94/106	319/319	108/121	110/125	99/111	323/323	
		112A+117A	31.8/42.4	88.4/102.0	124/141	125/150	114/129	314/314	129/146	150/150	118/134	318/318	130/147	150/150	119/135	319/319	135/152	150/175	124/139	323/323	
		112A+110A	37.6/50.0	104.2/120.3	144/134	150/150	132/151	314/314	149/139	150/150	136/155	318/318	150/140	150/150	138/156	319/319	155/145	175/175	142/160	323/323	
	HIGH	NONE	-	-	53/52	60/60	55/54	316	56/55	60/60	60/59	320	57/56	70/60	61/60	321	61/60	70/70	65/64	325	
		117A	7.8/10.4	21.7/25.0	53/52	60/60	55/54	316/316	56/55	60/60	60/59	320/320	57/56	70/60	61/60	321/321	61/60	70/70	65/64	325/325	
		110A	12.0/16.0	33.4/38.5	59/64	60/70	55/59	316/316	64/69	70/70	60/63	320/320	65/70	70/70	61/64	321/321	70/75	70/80	65/69	325/325	
		112A	24.0/32.0	66.7/77.0	101/113	110/125	92/103	316/316	106/117	110/125	97/108	320/320	107/119	110/125	98/109	321/321	112/123	125/125	102/113	325/325	
		112A+117A	31.8/42.4	88.4/102.0	128/144	150/150	117/132	316/316	133/149	150/150	122/136	320/320	134/150	150/150	123/137	321/321	139/155	150/175	127/142	325/325	
		112A+110A	37.6/50.0	104.2/120.3	148/137	150/150	135/153	316/316	152/141	175/175	140/157	320/320	154/143	175/175	141/158	321/321	158/147	175/175	145/163	325/325	
558J-12D (2-Circuit / 2-Stage Cooling)	STD	NONE	-	-	22	25	23	123	24	30	25	125	24	30	25	125	26	30	27	127	
		116B	13.9	16.7	25	25	23	123	27	30	25	125	27	30	25	125	30	30	27	127	
		113B	16.5	19.8	28	30	26	123	31	35	28	125	31	35	28	125	33	35	30	127	
		115B	33.0	39.7	53	60	49	123	56	60	51	125	56	60	51	125	58	60	53	127	
		128B	41.7	50.2	66	70	61	123	69	70	63	125	69	70	63	125	71	80	65	127	
		129B	50.0	60.1	64	70	72	123	66	70	74	125	67	70	75	125	69	70	77	127	
	MED	NONE	-	-	25	30	26	151	26	30	28	153	27	30	28	153	29	35	30	155	
		116B	13.9	16.7	28	30	26	151	30	30	28	153	31	35	28	153	33	35	30	155	
		113B	16.5	19.8	32	35	29	151	34	35	31	153	35	35	31	153	37	40	33	155	
		115B	33.0	39.7	57	60	52	151	59	60	54	153	59	60	54	153	62	70	56	155	
		128B	41.7	50.2	70	70	64	151	72	80	66	153	73	80	66	153	75	80	68	155	
		129B	50.0	60.1	67	80	75	151	69	80	77	153	70	80	78	153	72	80	80	155	
	HIGH	NONE	-	-	26	30	27	152	28	30	29	154	28	30	29	154	30	35	32	156	
		116B	13.9	16.7	29	30	27	152	32	35	29	154	32	35	29	154	34	35	32	156	
		113B	16.5	19.8	33	35	30	152	35	35	32	154	36	40	33	154	38	40	35	156	
		115B	33.0	39.7	58	60	53	152	60	60	55	154	61	70	56	154	63	70	58	156	
		128B	41.7	50.2	71	80	65	152	73	80	67	154	74	80	68	154	76	80	70	156	
		129B	50.0	60.1	69	80	76	152	71	80	79	154	71	80	79	154	74	80	81	156	
575-3-60	STD	NONE	-	-	17	20	17	93	20	25	21	97	18	20	19	95	22	25	23	99	
		118A	18.0	17.3	25	25	22	93	29	30	27	97	27	30	24	95	31	35	29	99	
		119A	36.0	34.6	46	50	42	93	51	60	46	97	48	50	44	95	53	60	48	99	
		118A+119A	54.0	52.0	55	60	62	93	60	60	66	97	57	60	64	95	62	70	68	99	
	MED	NONE	-	-	17	20	18	104	21	25	22	108	19	25	20	106	23	25	24	110	
		118A	18.0	17.3	26	30	23	104	30	30	27	108	28	30	25	106	32	35	29	110	
		119A	36.0	34.6	47	50	43	104	52	60	47	108	49	50	45	106	54	60	49	110	
		118A+119A	54.0	52.0	56	60	63	104	61	70	67	108	58	60	65	106	63	70	69	110	
	HIGH	NONE	-	-	20	25	21	118	24	30	25	122	22	25	23	120	26	30	27	124	
		118A	18.0	17.3	29	30	26	118	34	35	31	122	31	35	28	120	36	40	33	124	
		119A	36.0	34.6	51	60	46	118	55	60	51	122	53	60	48	120	58	60	53	124	
		118A+119A	54.0	52.0	59	70	66	118	64	70	71	122	62	70	68	120	66	70	73	124	

See Legend and Notes on page 54.

**UNIT WIRE/FUSE OR HACR BREAKER SIZING DATA -
1-SPEED INDOOR FAN MOTOR, 6-15 TONS (CONT)**

SIZE/STAGE	NOM. V-Ph-Hz	IFM TYPE	ELECTRIC HEATER			NO CONVENIENCE OUTLET (C.O.) or UNPWR C.O.						w/ PWRD C.O.									
			CRHEATER ***A00	Nom (kW)	FLA	NO Power Exhaust (P.E.)				w/ P.E. (pwrd fr/ unit)				NO P.E.				w/ P.E. (pwrd fr/ unit)			
						MCA	Fuse or Hacr Brkr	DISC. SIZE		MCA	Fuse or Hacr Brkr	DISC. SIZE		MCA	Fuse or Hacr Brkr	DISC. SIZE		MCA	Fuse or Hacr Brkr	DISC. SIZE	
								FLA	LRA			FLA	LRA			FLA	LRA			FLA	LRA
558J-12N (1-Circuit / 2-Stage Cooling)	208/230-3-60	STD	NONE	-	-	49	60	47	278	53	80	51	282	54	80	52	283	58	80	57	287
			117A	7.8/10.4	21.7/25.0	49/49	60/60	47/47	278/278	53/53	80/80	51/51	282/282	54/54	80/80	52/52	283/283	58/58	80/80	57/57	287/287
			110A	12.0/16.0	33.4/38.5	49/55	60/60	47/50	278/278	53/60	80/80	51/55	282/282	55/61	80/80	52/56	283/283	59/66	80/80	57/60	287/287
			112A	24.0/32.0	66.7/77.0	90/103	90/110	83/95	278/278	95/108	100/110	87/99	282/282	96/109	100/110	88/100	283/283	101/114	110/125	93/104	287/287
			112A+117A	31.8/42.4	88.4/102.0	117/134	125/150	108/123	278/278	122/139	125/150	112/128	282/282	123/140	125/150	113/129	283/283	128/145	150/150	118/133	287/287
			112A+110A	37.6/50.0	104.2/120.3	137/127	150/150	126/144	278/278	142/132	150/150	130/149	282/282	143/133	150/150	131/150	283/283	148/138	150/150	136/154	287/287
		MED	NONE	-	-	55	80	53	334	58	80	57	338	59	80	59	339	63	80	63	343
			117A	7.8/10.4	21.7/25.0	55/55	80/80	53/53	334/334	58/58	80/80	57/57	338/338	59/59	80/80	59/59	339/339	63/63	80/80	63/63	343/343
			110A	12.0/16.0	33.4/38.5	55/62	80/80	53/56	334/334	60/67	80/80	57/61	338/338	61/68	80/80	59/62	339/339	66/73	80/80	63/66	343/343
			112A	24.0/32.0	66.7/77.0	97/110	100/110	89/101	334/334	102/115	110/125	93/105	338/338	103/116	110/125	94/106	339/339	108/121	110/125	99/111	343/343
			112A+117A	31.8/42.4	88.4/102.0	124/141	125/150	114/129	334/334	129/146	150/150	118/134	338/338	130/147	150/150	119/135	339/339	135/152	150/175	124/139	343/343
			112A+110A	37.6/50.0	104.2/120.3	144/134	150/150	132/151	334/334	149/139	150/150	136/155	338/338	150/140	150/150	138/156	339/339	155/145	175/175	142/160	343/343
	HIGH	NONE	-	-	58/57	80/80	56/55	336	61/61	80/80	61/60	340	62/62	80/80	62/61	341	66/65	80/80	66/65	345	
		117A	7.8/10.4	21.7/25.0	58/57	80/80	56/55	336/336	61/61	80/80	61/60	340/340	62/62	80/80	62/61	341/341	66/65	80/80	66/65	345/345	
		110A	12.0/16.0	33.4/38.5	59/64	80/80	56/59	336/336	64/69	80/80	61/63	340/340	65/70	80/80	62/64	341/341	70/75	80/80	66/69	345/345	
		112A	24.0/32.0	66.7/77.0	101/113	110/125	92/103	336/336	106/117	110/125	97/108	340/340	107/119	110/125	98/109	341/341	112/123	125/125	102/113	345/345	
		112A+117A	31.8/42.4	88.4/102.0	128/144	150/150	117/132	336/336	133/149	150/150	122/136	340/340	134/150	150/150	123/137	341/341	139/155	150/175	127/142	345/345	
		112A+110A	37.6/50.0	104.2/120.3	148/137	150/150	135/153	336/336	152/141	175/175	140/157	340/340	154/143	175/175	141/158	341/341	158/147	175/175	145/163	345/345	
	460-3-60	STD	NONE	-	-	23	30	22	149	25	30	24	151	25	30	24	151	27	40	26	153
			116B	13.9	16.7	25	30	22	149	27	30	24	151	27	30	25	151	30	40	27	153
			113B	16.5	19.8	28	30	26	149	31	35	28	151	31	35	28	151	33	40	30	153
			115B	33.0	39.7	53	60	49	149	56	60	51	151	56	60	51	151	58	60	53	153
			128B	41.7	50.2	66	70	61	149	69	70	63	151	69	70	63	151	71	80	65	153
			129B	50.0	60.1	64	70	72	149	66	70	74	151	67	70	75	151	69	70	77	153
MED		NONE	-	-	26	30	25	177	28	40	27	179	28	40	27	179	30	40	30	181	
		116B	13.9	16.7	28	30	25	177	30	40	27	179	31	40	28	179	33	40	30	181	
		113B	16.5	19.8	32	40	29	177	34	40	31	179	35	40	31	179	37	40	33	181	
		115B	33.0	39.7	57	60	52	177	59	60	54	179	59	60	54	179	62	70	56	181	
		128B	41.7	50.2	70	70	64	177	72	80	66	179	73	80	66	179	75	80	68	181	
		129B	50.0	60.1	67	80	75	177	69	80	77	179	70	80	78	179	72	80	80	181	
HIGH		NONE	-	-	27	40	26	178	29	40	28	180	29	40	29	180	31	45	31	182	
		116B	13.9	16.7	29	40	27	178	32	40	29	180	32	40	29	180	34	45	31	182	
		113B	16.5	19.8	33	40	30	178	35	40	32	180	36	40	33	180	38	45	35	182	
		115B	33.0	39.7	58	60	53	178	60	60	55	180	61	70	56	180	63	70	58	182	
		128B	41.7	50.2	71	80	65	178	73	80	67	180	74	80	68	180	76	80	70	182	
		129B	50.0	60.1	69	80	76	178	71	80	79	180	71	80	79	180	74	80	81	182	
575-3-60	STD	NONE	-	-	18	25	16	109	21	30	21	113	19	25	18	111	23	30	23	115	
		118A	18.0	17.3	25	25	22	109	29	30	27	113	27	30	24	111	31	35	29	115	
		119A	36.0	34.6	46	50	42	109	51	60	46	113	48	50	44	111	53	60	48	115	
		118A+119A	54.0	52.0	55	60	62	109	60	60	66	113	57	60	64	111	62	70	68	115	
	MED	NONE	-	-	18	25	17	120	22	30	22	124	20	30	19	122	24	30	24	126	
		118A	18.0	17.3	26	30	23	120	30	30	27	124	28	30	25	122	32	35	29	126	
		119A	36.0	34.6	47	50	43	120	52	60	47	124	49	50	45	122	54	60	49	126	
		118A+119A	54.0	52.0	56	60	63	120	61	70	67	124	58	60	65	122	63	70	69	126	
	HIGH	NONE	-	-	21	30	21	134	25	30	25	138	23	30	23	136	27	30	27	140	
		118A	18.0	17.3	29	30	26	134	34	35	31	138	31	35	28	136	36	40	33	140	
		119A	36.0	34.6	51	60	46	134	55	60	51	138	53	60	48	136	58	60	53	140	
		118A+119A	54.0	52.0	59	70	66	134	64	70	71	138	62	70	68	136	66	70	73	140	

See Legend and Notes on page 54.

ELECTRICAL DATA (CONT)

UNIT WIRE/FUSE OR HACR BREAKER SIZING DATA - 1-SPEED INDOOR FAN MOTOR, 6-15 TONS (CONT)

SIZE/STAGE	NOM. V-Ph-Hz	IFM TYPE	ELECTRIC HEATER			NO CONVENIENCE OUTLET (C.O.) or UNPWR C.O.						w/ PWRD C.O.									
			CRHEATER ***A00	Nom (kW)	FLA	NO Power Exhaust (P.E.)			w/ P.E. (pwrdr fr/ unit)			NO P.E.				w/ P.E. (pwrdr fr/ unit)					
						MCA	Fuse or Hacr Brkr	DISC. SIZE		MCA	Fuse or Hacr Brkr	DISC. SIZE		MCA	Fuse or Hacr Brkr	DISC. SIZE		MCA	Fuse or Hacr Brkr	DISC. SIZE	
								FLA	LRA			FLA	LRA			FLA	LRA			FLA	LRA
208/230-3-60	STD	NONE	-	-	63/63	80/80	65/65	389	66/66	80/80	69/69	393	67/67	80/80	71/70	394	71/71	80/80	75/75	398	
		117A	7.8/10.4	21.7/25.0	63/63	80/80	65/65	389/389	66/66	80/80	69/69	393/393	67/67	80/80	71/70	394/394	71/71	80/80	75/75	398/398	
		110A	12.0/16.0	33.4/38.5	63/63	80/80	65/65	389/389	66/66	80/80	69/69	393/393	67/67	80/80	71/70	394/394	71/71	80/80	75/75	398/398	
		112A	24.0/32.0	66.7/77.0	94/107	100/110	86/98	389/389	99/112	100/125	91/102	393/393	100/113	100/125	92/104	394/394	105/118	110/125	96/108	398/398	
		112A+117A	31.8/42.4	88.4/102.0	121/138	125/150	111/127	389/389	126/143	150/150	116/131	393/393	127/144	150/150	117/132	394/394	132/149	150/150	121/137	398/398	
		112A+110A	37.6/50.0	104.2/120.3	141/131	150/150	129/148	389/389	146/136	150/150	134/152	393/393	147/137	150/150	135/153	394/394	152/142	175/150	139/158	398/398	
	MED	NONE	-	-	65	80	68	403	69	80	72	407	70	80	73	408	73	80	78	412	
		117A	7.8/10.4	21.7/25.0	65/65	80/80	68/68	403/403	69/69	80/80	72/72	407/407	70/70	80/80	73/73	408/408	73/73	80/80	78/78	412/412	
		110A	12.0/16.0	33.4/38.5	65/65	80/80	68/68	403/403	69/69	80/80	72/72	407/407	70/70	80/80	73/73	408/408	73/73	80/80	78/78	412/412	
		112A	24.0/32.0	66.7/77.0	97/110	100/110	89/101	403/403	102/115	110/125	93/105	407/407	103/116	110/125	94/106	408/408	108/121	110/125	99/111	412/412	
		112A+117A	31.8/42.4	88.4/102.0	124/141	125/150	114/129	403/403	129/146	150/150	118/134	407/407	130/147	150/150	119/135	408/408	135/152	150/175	124/139	412/412	
		112A+110A	37.6/50.0	104.2/120.3	144/134	150/150	132/151	403/403	149/139	150/150	136/155	407/407	150/140	150/150	138/156	408/408	155/145	175/175	142/160	412/412	
	HIGH	NONE	-	-	68/67	80/80	71/70	405	72/71	80/80	75/74	409	73/72	80/80	77/76	410	76/76	90/90	81/80	414	
		117A	7.8/10.4	21.7/25.0	68/67	80/80	71/70	405/405	72/71	80/80	75/74	409/409	73/72	80/80	77/76	410/410	76/76	90/90	81/80	414/414	
		110A	12.0/16.0	33.4/38.5	68/67	80/80	71/70	405/405	72/71	80/80	75/74	409/409	73/72	80/80	77/76	410/410	76/76	90/90	81/80	414/414	
		112A	24.0/32.0	66.7/77.0	101/113	110/125	92/103	405/405	106/117	110/125	97/108	409/409	107/119	110/125	98/109	410/410	112/123	125/125	102/113	414/414	
		112A+117A	31.8/42.4	88.4/102.0	128/144	150/150	117/132	405/405	133/149	150/150	122/136	409/409	134/150	150/150	123/137	410/410	139/155	150/175	127/142	414/414	
		112A+110A	37.6/50.0	104.2/120.3	148/137	150/150	135/153	405/405	152/141	175/175	140/157	409/409	154/143	175/175	141/158	410/410	158/147	175/175	145/163	414/414	
558J-14D (2-Circuit / 2-Stage Cooling)	STD	NONE	-	-	29	35	30	193	31	40	32	195	31	40	33	195	33	40	35	197	
		116B	13.9	16.7	29	35	30	193	31	40	32	195	31	40	33	195	33	40	35	197	
		113B	16.5	19.8	30	35	30	193	33	40	32	195	33	40	33	195	35	40	35	197	
		115B	33.0	39.7	55	60	50	193	58	60	53	195	58	60	53	195	60	60	55	197	
		128B	41.7	50.2	68	70	63	193	71	80	65	195	71	80	65	195	73	80	67	197	
		129B	50.0	60.1	66	70	74	193	68	80	76	195	69	80	76	195	71	80	79	197	
	MED	NONE	-	-	30	40	31	200	32	40	33	202	33	40	34	202	34	40	36	204	
		116B	13.9	16.7	30	40	31	200	32	40	33	202	33	40	34	202	34	40	36	204	
		113B	16.5	19.8	32	40	31	200	34	40	33	202	35	40	34	202	37	40	36	204	
		115B	33.0	39.7	57	60	52	200	59	60	54	202	59	60	54	202	62	70	56	204	
		128B	41.7	50.2	70	70	64	200	72	80	66	202	73	80	66	202	75	80	68	204	
		129B	50.0	60.1	67	80	75	200	69	80	77	202	70	80	78	202	72	80	80	204	
	HIGH	NONE	-	-	31	40	33	201	33	40	35	203	34	40	35	203	35	45	37	205	
		116B	13.9	16.7	31	40	33	201	33	40	35	203	34	40	35	203	35	45	37	205	
		113B	16.5	19.8	33	40	33	201	35	40	35	203	36	40	35	203	38	45	37	205	
		115B	33.0	39.7	58	60	53	201	60	60	55	203	61	70	56	203	63	70	58	205	
		128B	41.7	50.2	71	80	65	201	73	80	67	203	74	80	68	203	76	80	70	205	
		129B	50.0	60.1	69	80	76	201	71	80	79	203	71	80	79	203	74	80	81	205	
575-3-60	STD	NONE	-	-	22	25	23	147	26	30	27	151	24	30	24	149	27	30	29	153	
		118A	18.0	17.3	26	30	23	147	30	30	27	151	28	30	25	149	32	35	29	153	
		119A	36.0	34.6	47	50	43	147	52	60	47	151	49	50	45	149	54	60	49	153	
		118A+119A	54.0	52.0	56	60	63	147	61	70	67	151	58	60	65	149	63	70	69	153	
	MED	NONE	-	-	22	25	23	147	26	30	27	151	24	30	24	149	27	30	29	153	
		118A	18.0	17.3	26	30	23	147	30	30	27	151	28	30	25	149	32	35	29	153	
		119A	36.0	34.6	47	50	43	147	52	60	47	151	49	50	45	149	54	60	49	153	
		118A+119A	54.0	52.0	56	60	63	147	61	70	67	151	58	60	65	149	63	70	69	153	
	HIGH	NONE	-	-	25	30	26	161	29	35	30	165	26	30	28	163	30	35	32	167	
		118A	18.0	17.3	29	30	26	161	34	35	31	165	31	35	28	163	36	40	33	167	
		119A	36.0	34.6	51	60	46	161	55	60	51	165	53	60	48	163	58	60	53	167	
		118A+119A	54.0	52.0	59	70	66	161	64	70	71	165	62	70	68	163	66	70	73	167	

See Legend and Notes on page 54.

**UNIT WIRE/FUSE OR HACR BREAKER SIZING DATA -
1-SPEED INDOOR FAN MOTOR, 6-15 TONS (CONT)**

SIZE/STAGE	NOM. V/Ph-Hz	IFM TYPE	ELECTRIC HEATER			NO CONVENIENCE OUTLET (C.O.) or UNPWR C.O.								w/ PWRD C.O.							
			CRHEATER ***A00	Nom (kW)	FLA	NO Power Exhaust (P.E.)				w/ P.E. (pwrd fr/ unit)				NO P.E.				w/ P.E. (pwrd fr/ unit)			
						MCA	Fuse or Hacr Brkr	DISC. SIZE		MCA	Fuse or Hacr Brkr	DISC. SIZE		MCA	Fuse or Hacr Brkr	DISC. SIZE		MCA	Fuse or Hacr Brkr	DISC. SIZE	
								FLA	LRA			FLA	LRA			FLA	LRA			FLA	LRA
558J-16D (2-Circuit / 2-Stage Cooling)	208/230-3-60	STD	NONE	-	-	70/70	80/80	72/72	412	73/73	80/80	77/77	416	74/74	90/90	78/78	417	78/78	100/100	82/82	421
			291A	12.4/16.5	34.4/39.7	70/70	80/80	72/72	412/412	73/73	80/80	77/77	416/416	74/74	90/90	78/78	417/417	78/78	100/100	82/82	421/421
			294A	25.2/33.5	69.9/80.6	98/112	100/125	90/102	412/412	103/116	110/125	94/107	416/416	104/118	110/125	96/108	417/417	109/122	110/125	100/112	421/421
			288A+294A	32.7/43.5	90.7/104.7	124/142	125/150	114/130	412/412	129/146	150/150	118/134	416/416	130/148	150/150	119/135	417/417	135/152	150/175	124/140	421/421
			291A+294A	37.6/50.0	104.3/120.3	141/131	150/150	130/148	412/412	146/136	150/150	134/152	416/416	147/137	150/150	135/153	417/417	152/142	175/150	139/158	421/421
			294A+294A	50.3/67.0	139.7/161.2	151/172	175/200	170/195	412/412	155/177	175/200	175/199	416/416	157/178	175/200	176/200	417/417	161/183	175/200	180/205	421/421
		MED	NONE	-	-	72	80	75	426	76	100	79	430	77	100	80	431	80	100	85	435
			291A	12.4/16.5	34.4/39.7	72/72	80/80	75/75	426/426	76/76	100/100	79/79	430/430	77/77	100/100	80/80	431/431	80/80	100/100	85/85	435/435
			294A	25.2/33.5	69.9/80.6	101/114	110/125	93/105	426/426	106/119	110/125	97/109	430/430	107/120	110/125	98/110	431/431	112/125	125/125	102/115	435/435
			288A+294A	32.7/43.5	90.7/104.7	127/145	150/150	116/133	426/426	132/149	150/150	121/137	430/430	133/151	150/175	122/138	431/431	138/155	150/175	126/142	435/435
			291A+294A	37.6/50.0	104.3/120.3	144/134	150/150	132/151	426/426	149/139	150/150	137/155	430/430	150/140	150/150	138/156	431/431	155/145	175/175	142/160	435/435
			294A+294A	50.3/67.0	139.7/161.2	153/175	175/200	173/198	426/426	158/180	175/200	177/202	430/430	159/181	175/200	178/203	431/431	164/186	175/200	183/207	435/435
	HIGH/ High Eff.	NONE	-	-	82	100	86	432	85	100	91	436	86	100	92	437	90	100	96	441	
		291A	12.4/16.5	34.4/39.7	82/82	100/100	86/86	432/432	85/85	100/100	91/91	436/436	86/86	100/100	92/92	437/437	90/90	100/100	96/96	441/441	
		294A	25.2/33.5	69.9/80.6	113/127	125/150	104/116	432/432	118/131	125/150	108/121	436/436	119/133	125/150	109/122	437/437	124/137	125/150	114/126	441/441	
		288A+294A	32.7/43.5	90.7/104.7	139/157	150/175	128/144	432/432	144/162	150/175	132/148	436/436	145/163	150/175	133/149	437/437	150/168	150/175	138/154	441/441	
		291A+294A	37.6/50.0	104.3/120.3	156/146	175/175	143/162	432/432	161/151	175/175	148/166	436/436	162/152	175/175	149/167	437/437	167/157	175/175	153/172	441/441	
		294A+294A	50.3/67.0	139.7/161.2	166/187	175/225	184/209	432/432	170/192	175/225	188/213	436/436	172/193	200/225	190/214	437/437	176/198	200/225	194/219	441/441	
	460-3-60	STD	NONE	-	-	35	45	36	242	37	45	38	244	37	45	39	244	39	50	41	246
			292A	16.5	19.9	35	45	36	242	37	45	38	244	37	45	39	244	39	50	41	246
			295A	33.5	40.3	56	60	51	242	58	60	53	244	59	60	54	244	61	70	56	246
			289A+295A	43.5	52.3	71	80	65	242	73	80	67	244	74	80	68	244	76	80	70	246
			292A+295A	50.0	60.2	66	70	74	242	68	80	76	244	69	80	77	244	71	80	79	246
			295A+295A	67.0	80.6	86	100	98	242	89	100	100	244	89	100	100	244	91	100	102	246
MED		NONE	-	-	36	45	38	249	38	50	40	251	39	50	40	251	40	50	42	253	
		292A	16.5	19.9	36	45	38	249	38	50	40	251	39	50	40	251	40	50	42	253	
		295A	33.5	40.3	57	60	52	249	60	60	55	251	60	60	55	251	62	70	57	253	
		289A+295A	43.5	52.3	72	80	66	249	75	80	68	251	75	80	69	251	77	80	71	253	
		292A+295A	50.0	60.2	67	80	75	249	70	80	77	251	70	80	78	251	72	80	80	253	
		295A+295A	67.0	80.6	88	100	99	249	90	100	101	251	90	100	101	251	93	100	103	253	
HIGH/ High Eff.	NONE	-	-	41	50	43	252	43	50	45	254	43	50	46	254	45	50	48	256		
	292A	16.5	19.9	41	50	43	252	43	50	45	254	43	50	46	254	45	50	48	256		
	295A	33.5	40.3	64	70	58	252	66	70	60	254	66	70	61	254	69	70	63	256		
	289A+295A	43.5	52.3	79	80	72	252	81	90	74	254	81	90	74	254	84	90	76	256		
	292A+295A	50.0	60.2	73	80	81	252	76	80	83	254	76	80	83	254	78	80	86	256		
	295A+295A	67.0	80.6	94	100	104	252	96	100	106	254	97	100	107	254	99	100	109	256		
575-3-60	STD	NONE	-	-	27	30	28	184	31	40	32	188	29	35	30	186	32	40	34	190	
		293A	16.5	15.9	27	30	28	184	31	40	32	188	29	35	30	186	32	40	34	190	
		296A	33.5	32.2	44	45	40	184	49	50	45	188	46	50	42	186	51	60	47	190	
		290A+296A	43.5	41.9	56	60	51	184	61	70	56	188	58	60	53	186	63	70	58	190	
		293A+296A	50.0	48.1	52	60	59	184	57	60	63	188	54	60	60	186	59	60	65	190	
		296A+296A	67.0	64.5	68	80	77	184	73	80	82	188	71	80	79	186	75	80	84	190	
	MED	NONE	-	-	27	30	28	184	31	40	32	188	29	35	30	186	32	40	34	190	
		293A	16.5	15.9	27	30	28	184	31	40	32	188	29	35	30	186	32	40	34	190	
		296A	33.5	32.2	44	45	40	184	49	50	45	188	46	50	42	186	51	60	47	190	
		290A+296A	43.5	41.9	56	60	51	184	61	70	56	188	58	60	53	186	63	70	58	190	
		293A+296A	50.0	48.1	52	60	59	184	57	60	63	188	54	60	60	186	59	60	65	190	
		296A+296A	67.0	64.5	68	80	77	184	73	80	82	188	71	80	79	186	75	80	84	190	
HIGH/ High Eff.	NONE	-	-	33	40	35	196	37	45	39	200	35	40	37	198	39	45	41	202		
	293A	16.5	15.9	33	40	35	196	37	45	39	200	35	40	37	198	39	45	41	202		
	296A	33.5	32.2	52	60	47	196	57	60	52	200	54	60	49	198	59	60	54	202		
	290A+296A	43.5	41.9	64	70	59	196	69	70	63	200	66	70	60	198	71	80	65	202		
	293A+296A	50.0	48.1	60	70	66	196	65	70	70	200	62	70	68	198	67	70	72	202		
	296A+296A	67.0	64.5	76	80	85	196	81	90	89	200	78	80	86	198	83	90	91	202		

See Legend and Notes on page 54.

ELECTRICAL DATA (CONT)

UNIT WIRE/FUSE OR HACR BREAKER SIZING DATA - 2-SPEED BLOWER INDOOR FAN MOTOR, 6-15 TONS

SIZE/STAGE	NOM. V-PH-Hz	IFM TYPE	ELECTRIC HEATER			NO CONVENIENCE OUTLET (C.O.) or UNPWR C.O.						w/ PWRD C.O.									
			CRHEATER ***A00	Nom (kW)	FLA	NO Power Exhaust (P.E.)			w/ P.E. (pwrdr fr/ unit)			NO P.E.			w/ P.E. (pwrdr fr/ unit)						
						MCA	Fuse or Hacr Brkr	DISC. SIZE		MCA	Fuse or Hacr Brkr	DISC. SIZE		MCA	Fuse or Hacr Brkr	DISC. SIZE		MCA	Fuse or Hacr Brkr	DISC. SIZE	
								FLA	LRA			FLA	LRA			FLA	LRA			FLA	LRA
558J-07A (1-Circuit / 1-Stage Cool)	208/230-3-60	STD	NONE	-	-	34/33	50/50	32/32	167	35/35	50/50	35/34	169	38/38	50/50	38/38	172	40/40	50/50	40/40	174
			102A	4.9/6.5	13.6/15.6	34/33	50/50	32/32	167/167	35/35	50/50	35/34	169/169	38/38	50/50	38/38	172/172	40/40	50/50	40/40	174/174
			104B	7.9/10.5	21.9/25.3	37/41	50/50	33/37	167/167	39/43	50/50	36/39	169/169	43/47	50/50	39/42	172/172	45/49	50/50	41/45	174/174
			105A	12.0/16.0	33.4/38.5	51/57	60/60	47/52	167/167	53/59	60/60	49/54	169/169	57/63	60/70	52/58	172/172	59/65	60/70	54/60	174/174
			104B+104B	15.8/21.0	43.8/50.5	64/72	70/80	59/66	167/167	66/74	70/80	61/68	169/169	70/78	70/80	64/71	172/172	72/80	80/90	66/74	174/174
			104B+105A	19.9/26.5	55.2/63.8	78/89	80/90	72/81	167/167	81/91	90/100	74/83	169/169	84/95	90/100	77/87	172/172	87/97	90/100	79/89	174/174
		MED	NONE	-	-	35/34	50/50	34/33	193	37/36	50/50	36/35	195	40/39	50/50	40/39	198	42/41	60/60	42/41	200
			102A	4.9/6.5	13.6/15.6	35/34	50/50	34/33	193/193	37/36	50/50	36/35	195/195	40/39	50/50	40/39	198/198	42/41	60/60	42/41	200/200
			104B	7.9/10.5	21.9/25.3	39/42	50/50	35/38	193/193	41/44	50/50	37/40	195/195	45/48	50/50	41/44	198/198	47/50	60/60	43/46	200/200
			105A	12.0/16.0	33.4/38.5	53/58	60/60	48/53	193/193	55/61	60/70	50/55	195/195	59/64	60/70	54/59	198/198	61/67	70/70	56/61	200/200
			104B+104B	15.8/21.0	43.8/50.5	66/73	70/80	60/67	193/193	68/76	70/80	62/69	195/195	72/79	80/80	66/73	198/198	74/82	80/90	68/75	200/200
			104B+105A	19.9/26.5	55.2/63.8	80/90	80/90	73/82	193/193	83/92	90/100	76/85	195/195	86/96	90/100	79/88	198/198	89/98	90/100	81/90	200/200
	HIGH	NONE	-	-	37/36	50/50	37/36	217	39/38	50/50	39/38	219	42/41	60/60	42/41	222	44/43	60/60	44/43	224	
		102A	4.9/6.5	13.6/15.6	37/36	50/50	37/36	217/217	39/38	50/50	39/38	219/219	42/41	60/60	42/41	222/222	44/43	60/60	44/43	224/224	
		104B	7.9/10.5	21.9/25.3	41/44	50/50	38/40	217/217	44/47	50/50	40/43	219/219	47/50	60/60	43/46	222/222	50/53	60/60	45/48	224/224	
		105A	12.0/16.0	33.4/38.5	56/61	60/70	51/56	217/217	58/63	60/70	53/58	219/219	62/67	70/70	56/61	222/222	64/69	70/70	59/63	224/224	
		104B+104B	15.8/21.0	43.8/50.5	69/76	70/80	63/69	217/217	71/78	80/80	65/72	219/219	75/82	80/90	68/75	222/222	77/84	80/90	70/77	224/224	
		104B+105A	19.9/26.5	55.2/63.8	83/92	90/100	76/85	217/217	85/95	90/100	78/87	219/219	89/98	90/100	81/90	222/222	91/101	100/110	84/92	224/224	
	460-3-60	STD	NONE	-	-	15	20	14	82	16	20	15	83	17	20	17	84	18	25	18	85
			106A	6.0	7.2	15	20	14	82	16	20	15	83	17	20	17	84	18	25	18	85
			108A	11.5	13.8	22	25	20	82	23	25	21	83	25	25	22	84	26	30	23	85
			109A	14.0	16.8	26	30	23	82	27	30	24	83	28	30	26	84	30	30	27	85
			108A+108A	23.0	27.7	39	40	36	82	41	45	37	83	42	45	38	84	43	45	39	85
			108A+109A	25.5	30.7	43	45	39	82	44	45	40	83	46	50	42	84	47	50	43	85
MED		NONE	-	-	15	20	15	95	16	20	16	96	18	25	17	97	19	25	18	98	
		106A	6.0	7.2	15	20	15	95	16	20	16	96	18	25	17	97	19	25	18	98	
		108A	11.5	13.8	22	25	20	95	24	25	21	96	25	25	23	97	26	30	24	98	
		109A	14.0	16.8	26	30	24	95	27	30	25	96	29	30	26	97	30	30	27	98	
		108A+108A	23.0	27.7	40	40	36	95	41	45	37	96	43	45	39	97	44	45	40	98	
		108A+109A	25.5	30.7	44	45	40	95	45	45	41	96	46	50	42	97	48	50	43	98	
HIGH	NONE	-	-	16	20	16	107	17	25	17	108	19	25	19	109	20	25	20	110		
	106A	6.0	7.2	16	20	16	107	17	25	17	108	19	25	19	109	20	25	20	110		
	108A	11.5	13.8	24	25	22	107	25	25	23	108	27	30	24	109	28	30	25	110		
	109A	14.0	16.8	28	30	25	107	29	30	26	108	30	30	27	109	32	35	29	110		
	108A+108A	23.0	27.7	41	45	37	107	42	45	39	108	44	45	40	109	45	45	41	110		
	108A+109A	25.5	30.7	45	45	41	107	46	50	42	108	48	50	43	109	49	50	45	110		
575-3-60	STD	NONE	-	-	13	15	12	70	15	20	14	72	15	20	14	72	16	20	16	74	
	MED	NONE	-	-	14	15	13	79	16	20	16	81	16	20	15	81	17	20	18	83	
	HIGH	NONE	-	-	14	15	13	79	16	20	16	81	16	20	15	81	17	20	18	83	

See Legend and Notes on page 54.

**UNIT WIRE/FUSE OR HACR BREAKER SIZING DATA -
2-SPEED INDOOR FAN MOTOR, 6-15 TONS (CONT)**

SIZE/STAGE	NOM. V-Ph-Hz	IFM TYPE	ELECTRIC HEATER			NO CONVENIENCE OUTLET (C.O.) or UNPWR C.O.								w/ PWRD C.O.							
			CRHEATER ***A00	Nom (kW)	FLA	NO Power Exhaust (P.E.)				w/ P.E. (pwrd fr/ unit)				NO P.E.				w/ P.E. (pwrd fr/ unit)			
						MCA	Fuse or Hacr Brkr	DISC. SIZE		MCA	Fuse or Hacr Brkr	DISC. SIZE		MCA	Fuse or Hacr Brkr	DISC. SIZE		MCA	Fuse or Hacr Brkr	DISC. SIZE	
								FLA	LRA			FLA	LRA			FLA	LRA			FLA	LRA
558J-08D (2-Circuit / 2-Stage Cooling)	208/230-3-Ø0	STD	NONE	-	-	40/40	50/50	41/41	197	44/43	50/50	46/46	201	45/44	50/50	47/47	202	48/48	60/60	51/51	206
			117A	7.8/10.4	21.7/25.0	40/40	50/50	41/41	197/197	44/43	50/50	46/46	201/201	45/45	50/50	47/47	202/202	48/49	60/60	51/51	206/206
			110A	12.0/16.0	33.4/38.5	49/56	50/60	45/51	197/197	54/60	60/60	49/55	201/201	55/62	60/70	51/56	202/202	60/66	60/70	55/61	206/206
			111A	18.6/24.8	51.7/59.7	72/82	80/90	66/75	197/197	77/87	80/90	70/79	201/201	78/88	80/90	72/81	202/202	83/93	90/100	76/85	206/206
			112A	24.0/32.0	66.7/77.0	91/104	100/110	83/95	197/197	96/108	100/110	88/99	201/201	97/110	100/110	89/101	202/202	102/114	110/125	93/105	206/206
			112A+117A	31.8/42.4	88.4/102.0	118/135	125/150	108/124	197/197	123/140	125/150	113/128	201/201	124/141	125/150	114/129	202/202	129/146	150/150	118/134	206/206
		MED	NONE	-	-	43/42	50/50	45/44	227	46/46	50/50	49/48	231	47/47	60/50	50/49	232	51/50	60/60	55/54	236
			117A	7.8/10.4	21.7/25.0	43/42	50/50	45/44	227/227	46/46	50/50	49/48	231/231	47/47	60/50	50/49	232/232	51/52	60/60	55/54	236/236
			110A	12.0/16.0	33.4/38.5	53/58	60/60	48/53	227/227	58/63	60/70	53/58	231/231	59/64	60/70	54/59	232/232	64/69	70/70	58/63	236/236
			111A	18.6/24.8	51.7/59.7	76/85	80/90	69/78	227/227	81/90	90/90	74/82	231/231	82/91	90/100	75/83	232/232	87/96	90/100	79/88	236/236
			112A	24.0/32.0	66.7/77.0	95/106	100/110	87/98	227/227	99/111	100/125	91/102	231/231	101/112	110/125	92/103	232/232	105/117	110/125	96/107	236/236
			112A+117A	31.8/42.4	88.4/102.0	122/138	125/150	112/126	227/227	126/142	150/150	116/131	231/231	128/144	150/150	117/132	232/232	132/148	150/150	121/136	236/236
	HIGH	NONE	-	-	48/47	60/50	50/49	262	51/51	60/60	55/54	266	52/52	60/60	56/55	267	56/55	60/60	60/59	271	
		117A	7.8/10.4	21.7/25.0	48/48	60/50	50/49	262/262	51/52	60/60	55/54	266/266	52/54	60/60	56/55	267/267	56/58	60/60	60/59	271/271	
		110A	12.0/16.0	33.4/38.5	59/64	60/70	54/59	262/262	64/69	70/70	58/63	266/266	65/70	70/70	60/64	267/267	70/75	70/80	64/69	271/271	
		111A	18.6/24.8	51.7/59.7	82/91	90/100	75/83	262/262	87/96	90/100	79/88	266/266	88/97	90/100	81/89	267/267	93/102	100/110	85/93	271/271	
		112A	24.0/32.0	66.7/77.0	101/113	110/125	92/103	262/262	106/117	110/125	97/108	266/266	107/119	110/125	98/109	267/267	112/123	125/125	102/113	271/271	
		112A+117A	31.8/42.4	88.4/102.0	128/144	150/150	117/132	262/262	133/149	150/150	122/136	266/266	134/150	150/150	123/137	267/267	139/155	150/175	127/142	271/271	
	460-3-Ø0	STD	NONE	-	-	19	20	19	97	20	25	21	99	21	25	22	99	23	25	24	101
			116B	13.9	16.7	25	25	23	97	27	30	25	99	28	30	25	99	30	30	27	101
			113B	16.5	19.8	29	30	26	97	31	35	28	99	32	35	29	99	34	35	31	101
			114B	27.8	33.4	46	50	42	97	48	50	44	99	49	50	44	99	51	60	46	101
			115B	33.0	39.7	54	60	49	97	56	60	51	99	56	60	52	99	59	60	54	101
			128B	41.7	50.2	67	70	61	97	69	70	63	99	70	70	64	99	72	80	66	101
MED		NONE	-	-	20	25	20	113	21	25	22	115	22	25	23	115	24	25	25	117	
		116B	13.9	16.7	26	30	24	113	28	30	26	115	29	30	26	115	31	35	28	117	
		113B	16.5	19.8	30	30	27	113	32	35	29	115	33	35	30	115	35	35	32	117	
		114B	27.8	33.4	47	50	43	113	49	50	45	115	50	50	45	115	52	60	47	117	
		115B	33.0	39.7	55	60	50	113	57	60	52	115	58	60	53	115	60	60	55	117	
		128B	41.7	50.2	68	70	62	113	70	70	64	115	71	80	65	115	73	80	67	117	
HIGH		NONE	-	-	22	25	23	130	24	30	25	132	24	30	26	132	26	30	28	134	
		116B	13.9	16.7	29	30	27	130	32	35	29	132	32	35	29	132	34	35	31	134	
		113B	16.5	19.8	33	35	30	130	35	35	32	132	36	40	33	132	38	40	35	134	
		114B	27.8	33.4	50	50	46	130	52	60	48	132	53	60	48	132	55	60	50	134	
		115B	33.0	39.7	58	60	53	130	60	60	55	132	61	70	56	132	63	70	58	134	
		128B	41.7	50.2	71	80	65	130	73	80	67	132	74	80	68	132	76	80	70	134	
575-3-Ø0	STD	NONE	-	-	14	15	14	79	18	20	19	83	16	20	16	81	19	25	21	85	
		118A	18.0	17.3	26	30	23	79	30	30	27	83	28	30	25	81	32	35	29	85	
		119A	36.0	34.6	47	50	43	79	52	60	47	83	49	50	45	81	54	60	49	85	
	MED	NONE	-	-	16	20	16	92	19	25	21	96	17	20	18	94	21	25	23	98	
		118A	18.0	17.3	28	30	25	92	32	35	29	96	30	30	27	94	35	35	31	98	
		119A	36.0	34.6	49	50	45	92	54	60	49	96	51	60	47	94	56	60	51	98	
	HIGH	NONE	-	-	18	20	18	106	22	25	23	110	20	25	20	108	23	25	24	112	
		118A	18.0	17.3	30	30	27	106	35	35	31	110	32	35	29	108	37	40	33	112	
		119A	36.0	34.6	51	60	47	106	56	60	51	110	54	60	49	108	58	60	53	112	

See Legend and Notes on page 54.

ELECTRICAL DATA (CONT)

UNIT WIRE/FUSE OR HACR BREAKER SIZING DATA - 2-SPEED INDOOR FAN MOTOR, 6-15 TONS (CONT)

SIZE/STAGE	NOM. V-FPH-Hz	IFM TYPE	ELECTRIC HEATER			NO CONVENIENCE OUTLET (C.O.) or UNPWR C.O.								w/ PWRD C.O.							
			CRHEATER ***A00	Nom (kW)	FLA	NO Power Exhaust (P.E.)				w/ P.E. (pwrdr fr/ unit)				NO P.E.				w/ P.E. (pwrdr fr/ unit)			
						MCA	Fuse or Hacr Brkr	DISC. SIZE		MCA	Fuse or Hacr Brkr	DISC. SIZE		MCA	Fuse or Hacr Brkr	DISC. SIZE		MCA	Fuse or Hacr Brkr	DISC. SIZE	
								FLA	LRA			FLA	LRA			FLA	LRA			FLA	LRA
558J-99D (2-Circuit / 2-Stage Cooling)	208/230-3-60	STD	NONE	-	-	41/41	50/50	43/42	212	45/45	50/50	47/47	216	46/46	50/50	48/48	217	50/49	60/60	52/52	221
			117A	7.8/10.4	21.7/25.0	41/41	50/50	43/42	212/212	45/45	50/50	47/47	216/216	46/46	50/50	48/48	217/217	50/49	60/60	52/52	221/221
			110A	12.0/16.0	33.4/38.5	49/56	50/60	45/51	212/212	54/60	60/60	49/55	216/216	55/62	60/70	51/56	217/217	60/66	60/70	55/61	221/221
			111A	18.6/24.8	51.7/59.7	72/82	80/90	66/75	212/212	77/87	80/90	70/79	216/216	78/88	80/90	72/81	217/217	83/93	90/100	76/85	221/221
			112A	24.0/32.0	66.7/77.0	91/104	100/110	83/95	212/212	96/108	100/110	88/99	216/216	97/110	100/110	89/101	217/217	102/114	110/125	93/105	221/221
			112A+117A	31.8/42.4	88.4/102.0	118/135	125/150	108/124	212/212	123/140	125/150	113/128	216/216	124/141	125/150	114/129	217/217	129/146	150/150	118/134	221/221
		MED	NONE	-	-	42/42	50/50	44/44	216	46/46	60/50	48/48	220	47/47	60/60	50/49	221	51/51	60/60	54/54	225
			117A	7.8/10.4	21.7/25.0	42/42	50/50	44/44	216/216	46/46	60/50	48/48	220/220	47/47	60/60	50/49	221/221	51/51	60/60	54/54	225/225
			110A	12.0/16.0	33.4/38.5	51/57	60/60	47/52	216/216	56/62	60/70	51/56	220/220	57/63	60/70	52/58	221/221	62/68	70/70	56/62	225/225
			111A	18.6/24.8	51.7/59.7	74/84	80/90	68/76	216/216	79/88	80/90	72/81	220/220	80/90	80/90	73/82	221/221	85/94	90/100	78/86	225/225
			112A	24.0/32.0	66.7/77.0	93/105	100/110	85/96	216/216	97/110	100/110	89/101	220/220	99/111	100/125	90/102	221/221	103/116	110/125	95/106	225/225
			112A+117A	31.8/42.4	88.4/102.0	120/136	125/150	110/125	216/216	125/141	125/150	114/129	220/220	126/142	150/150	115/131	221/221	131/147	150/150	120/135	225/225
	HIGH	NONE	-	-	46/45	60/50	48/47	266	50/49	60/60	53/52	270	51/50	60/60	54/53	271	55/54	60/60	58/57	275	
		117A	7.8/10.4	21.7/25.0	46/45	60/50	48/47	266/266	50/49	60/60	53/52	270/270	51/50	60/60	54/53	271/271	55/55	60/60	58/57	275/275	
		110A	12.0/16.0	33.4/38.5	56/61	60/70	51/56	266/266	60/66	60/70	55/60	270/270	62/67	70/70	56/61	271/271	66/72	70/80	61/65	275/275	
		111A	18.6/24.8	51.7/59.7	79/87	80/90	72/80	266/266	83/92	90/100	76/84	270/270	85/93	90/100	77/85	271/271	89/98	90/100	82/90	275/275	
		112A	24.0/32.0	66.7/77.0	97/109	100/110	89/100	266/266	102/114	110/125	93/104	270/270	103/115	110/125	95/105	271/271	108/120	110/125	99/110	275/275	
		112A+117A	31.8/42.4	88.4/102.0	124/140	125/150	114/129	266/266	129/145	150/150	118/133	270/270	130/146	150/150	120/134	271/271	135/151	150/175	124/138	275/275	
	460-3-60	STD	NONE	-	-	19	25	20	111	21	25	22	113	21	25	22	113	23	25	24	115
			116B	13.9	16.7	25	25	23	111	27	30	25	113	28	30	25	113	30	30	27	115
			113B	16.5	19.8	29	30	26	111	31	35	28	113	32	35	29	113	34	35	31	115
			114B	27.8	33.4	46	50	42	111	48	50	44	113	49	50	44	113	51	60	46	115
			115B	33.0	39.7	54	60	49	111	56	60	51	113	56	60	52	113	59	60	54	115
			128B	41.7	50.2	67	70	61	111	69	70	63	113	70	70	64	113	72	80	66	115
MED		NONE	-	-	20	25	20	114	21	25	22	116	22	25	23	116	24	25	25	118	
		116B	13.9	16.7	26	30	23	114	28	30	25	116	28	30	26	116	31	35	28	118	
		113B	16.5	19.8	29	30	27	114	32	35	29	116	32	35	29	116	34	35	31	118	
		114B	27.8	33.4	46	50	42	114	49	50	44	116	49	50	45	116	51	60	47	118	
		115B	33.0	39.7	54	60	50	114	57	60	52	116	57	60	52	116	59	60	54	118	
		128B	41.7	50.2	67	70	62	114	70	70	64	116	70	70	64	116	72	80	66	118	
HIGH		NONE	-	-	21	25	22	139	23	25	24	141	23	25	24	141	25	30	26	143	
		116B	13.9	16.7	27	30	25	139	30	30	27	141	30	30	27	141	32	35	29	143	
		113B	16.5	19.8	31	35	28	139	34	35	30	141	34	35	31	141	36	40	33	143	
		114B	27.8	33.4	48	50	44	139	51	60	46	141	51	60	47	141	53	60	49	143	
		115B	33.0	39.7	56	60	51	139	58	60	53	141	59	60	54	141	61	70	56	143	
		128B	41.7	50.2	69	70	63	139	72	80	65	141	72	80	66	141	74	80	68	143	
575-3-60	STD	NONE	-	-	17	20	17	87	21	25	21	91	18	20	19	89	22	25	23	93	
		118A	18.0	17.3	26	30	23	87	30	30	27	91	28	30	25	89	32	35	29	93	
		119A	36.0	34.6	47	50	43	87	52	60	47	91	49	50	45	89	54	60	49	93	
	MED	NONE	-	-	17	20	18	91	21	25	22	95	19	25	20	93	23	25	24	97	
		118A	18.0	17.3	26	30	24	91	31	35	28	95	29	30	26	93	33	35	30	97	
		119A	36.0	34.6	48	50	44	91	53	60	48	95	50	50	46	93	55	60	50	97	
	HIGH	NONE	-	-	18	20	19	100	22	25	23	104	20	25	21	102	24	30	25	106	
		118A	18.0	17.3	28	30	25	100	32	35	29	104	30	30	27	102	35	35	31	106	
		119A	36.0	34.6	49	50	45	100	54	60	49	104	51	60	47	102	56	60	51	106	

See Legend and Notes on page 54.

**UNIT WIRE/FUSE OR HACR BREAKER SIZING DATA -
2-SPEED INDOOR FAN MOTOR, 6-15 TONS (CONT)**

SIZE/STAGE	NOM. V-Ph-Hz	IFM TYPE	ELECTRIC HEATER			NO CONVENIENCE OUTLET (C.O.) or UNPWR C.O.								w/ PWRD C.O.							
			CRHEATER ***A00	Nom (kW)	FLA	NO Power Exhaust (P.E.)				w/ P.E. (pwrd fr/ unit)				NO P.E.				w/ P.E. (pwrd fr/ unit)			
						MCA	Fuse or Hacr Brkr	DISC. SIZE		MCA	Fuse or Hacr Brkr	DISC. SIZE		MCA	Fuse or Hacr Brkr	DISC. SIZE		MCA	Fuse or Hacr Brkr	DISC. SIZE	
								FLA	LRA			FLA	LRA			FLA	LRA			FLA	LRA
558J-12D (2-Circuit / 2-Stage Cooling)	208/230-3-60	STD	NONE	-	-	46/46	60/60	48/47	255	50/50	60/60	52/52	259	51/51	60/60	53/53	260	55/54	60/60	58/57	264
			117A	7.8/10.4	21.7/25.0	46/46	60/60	48/47	255/255	50/50	60/60	52/52	259/259	51/51	60/60	53/53	260/260	55/54	60/60	58/57	264/264
			110A	12.0/16.0	33.4/38.5	51/57	60/60	48/52	255/255	56/62	60/70	52/56	259/259	57/63	60/70	53/58	260/260	62/68	70/70	58/62	264/264
			112A	24.0/32.0	66.7/77.0	93/105	100/110	85/96	255/255	97/110	100/110	89/101	259/259	99/111	100/125	90/102	260/260	103/116	110/125	95/106	264/264
			112A+117A	31.8/42.4	88.4/102.0	120/136	125/150	110/125	255/255	125/141	125/150	114/129	259/259	126/142	150/150	115/131	260/260	131/147	150/150	120/135	264/264
			112A+110A	37.6/50.0	104.2/120.3	140/129	150/150	128/146	255/255	144/134	150/150	132/151	259/259	146/135	150/150	134/152	260/260	150/140	150/150	138/156	264/264
		MED	NONE	-	-	50/49	60/60	52/51	305	54/53	60/60	56/55	309	55/54	60/60	58/56	310	58/57	70/70	62/61	314
			117A	7.8/10.4	21.7/25.0	50/49	60/60	52/51	305/305	54/53	60/60	56/55	309/309	55/54	60/60	58/56	310/310	58/57	70/70	62/61	314/314
			110A	12.0/16.0	33.4/38.5	56/61	60/70	52/56	305/305	60/66	60/70	56/60	309/309	62/67	70/70	58/61	310/310	66/72	70/80	62/65	314/314
			112A	24.0/32.0	66.7/77.0	97/109	100/110	89/100	305/305	102/114	110/125	93/104	309/309	103/115	110/125	95/105	310/310	108/120	110/125	99/110	314/314
			112A+117A	31.8/42.4	88.4/102.0	124/140	125/150	114/129	305/305	129/145	150/150	118/133	309/309	130/146	150/150	120/134	310/310	135/151	150/175	124/138	314/314
			112A+110A	37.6/50.0	104.2/120.3	144/133	150/150	132/150	305/305	149/138	150/150	137/154	309/309	150/139	150/150	138/155	310/310	155/144	175/175	142/160	314/314
		HIGH	NONE	-	-	53/52	60/60	55/54	316	56/55	60/60	60/59	320	57/56	70/60	61/60	321	61/60	70/70	65/64	325
			117A	7.8/10.4	21.7/25.0	53/52	60/60	55/54	316/316	56/55	60/60	60/59	320/320	57/56	70/60	61/60	321/321	61/60	70/70	65/64	325/325
			110A	12.0/16.0	33.4/38.5	59/64	60/70	55/59	316/316	64/69	70/70	60/63	320/320	65/70	70/70	61/64	321/321	70/75	70/80	65/69	325/325
			112A	24.0/32.0	66.7/77.0	101/113	110/125	92/103	316/316	106/117	110/125	97/108	320/320	107/119	110/125	98/109	321/321	112/123	125/125	102/113	325/325
			112A+117A	31.8/42.4	88.4/102.0	128/144	150/150	117/132	316/316	133/149	150/150	122/136	320/320	134/150	150/150	123/137	321/321	139/155	150/175	127/142	325/325
			112A+110A	37.6/50.0	104.2/120.3	148/137	150/150	135/153	316/316	152/141	175/175	140/157	320/320	154/143	175/175	141/158	321/321	158/147	175/175	145/163	325/325
	460-3-60	STD	NONE	-	-	23	30	23	122	25	30	26	124	25	30	26	124	27	30	28	126
			116B	13.9	16.7	26	30	23	122	28	30	26	124	28	30	26	124	31	35	28	126
			113B	16.5	19.8	29	30	27	122	32	35	29	124	32	35	29	124	34	35	31	126
			115B	33.0	39.7	54	60	50	122	57	60	52	124	57	60	52	124	59	60	54	126
			128B	41.7	50.2	67	70	62	122	70	70	64	124	70	70	64	124	72	80	66	126
			129B	50.0	60.1	65	70	73	122	67	70	75	124	68	70	76	124	70	80	78	126
MED		NONE	-	-	24	30	25	147	26	30	27	149	26	30	28	149	28	30	30	151	
		116B	13.9	16.7	27	30	25	147	30	30	27	149	30	30	28	149	32	35	30	151	
		113B	16.5	19.8	31	35	28	147	34	35	30	149	34	35	31	149	36	40	33	151	
		115B	33.0	39.7	56	60	51	147	58	60	53	149	59	60	54	149	61	70	56	151	
		128B	41.7	50.2	69	70	63	147	72	80	65	149	72	80	66	149	74	80	68	151	
		129B	50.0	60.1	67	80	75	147	69	80	77	149	69	80	77	149	72	80	79	151	
HIGH		NONE	-	-	26	30	27	152	28	30	29	154	28	30	29	154	30	35	32	156	
		116B	13.9	16.7	29	30	27	152	32	35	29	154	32	35	29	154	34	35	32	156	
		113B	16.5	19.8	33	35	30	152	35	35	32	154	36	40	33	154	38	40	35	156	
		115B	33.0	39.7	58	60	53	152	60	60	55	154	61	70	56	154	63	70	58	156	
		128B	41.7	50.2	71	80	65	152	73	80	67	154	74	80	68	154	76	80	70	156	
		129B	50.0	60.1	69	80	76	152	71	80	79	154	71	80	79	154	74	80	81	156	
575-3-60	STD	NONE	-	-	18	20	19	95	22	25	23	99	20	25	21	97	24	25	25	101	
		118A	18.0	17.3	26	30	24	95	31	35	28	99	29	30	26	97	33	35	30	101	
		119A	36.0	34.6	48	50	44	95	53	60	48	99	50	50	46	97	55	60	50	101	
		118A+119A	54.0	52.0	57	60	64	95	62	70	68	99	59	60	66	97	64	70	70	101	
	MED	NONE	-	-	19	25	20	104	23	25	24	108	21	25	22	106	25	30	26	110	
		118A	18.0	17.3	28	30	25	104	32	35	29	108	30	30	27	106	35	35	31	110	
		119A	36.0	34.6	49	50	45	104	54	60	49	108	51	60	47	106	56	60	51	110	
		118A+119A	54.0	52.0	58	60	65	104	63	70	69	108	60	70	67	106	65	70	71	110	
	HIGH	NONE	-	-	21	25	22	118	25	30	26	122	23	25	24	120	26	30	28	124	
		118A	18.0	17.3	30	30	27	118	35	35	31	122	32	35	29	120	37	40	33	124	
		119A	36.0	34.6	51	60	47	118	56	60	51	122	54	60	49	120	58	60	53	124	
		118A+119A	54.0	52.0	60	70	67	118	65	70	71	122	62	70	69	120	67	70	73	124	

See Legend and Notes on page 54.

ELECTRICAL DATA (CONT)

UNIT WIRE/FUSE OR HACR BREAKER SIZING DATA - 2-SPEED INDOOR FAN MOTOR, 6-15 TONS (CONT)

SIZE/STAGE	NOM. V-Ph-Hz	IFM TYPE	ELECTRIC HEATER			NO CONVENIENCE OUTLET (C.O.) or UNPWR C.O.						w/ PWRD C.O.									
			CRHEATER ***A00	Nom (kW)	FLA	NO Power Exhaust (P.E.)			w/ P.E. (pwrdr fr/ unit)			NO P.E.				w/ P.E. (pwrdr fr/ unit)					
						MCA	Fuse or Hacr Brkr	DISC. SIZE		MCA	Fuse or Hacr Brkr	DISC. SIZE		MCA	Fuse or Hacr Brkr	DISC. SIZE		MCA	Fuse or Hacr Brkr	DISC. SIZE	
								FLA	LRA			FLA	LRA			FLA	LRA			FLA	LRA
208/230-3-60	STD	NONE	-	-	63/62	80/80	65/64	370	67/66	80/80	70/69	374	68/67	80/80	71/70	375	71/71	80/80	75/74	379	
		117A	7.8/10.4	21.7/25.0	63/62	80/80	65/64	370/370	67/66	80/80	70/69	374/374	68/67	80/80	71/70	375/375	71/71	80/80	75/74	379/379	
		110A	12.0/16.0	33.4/38.5	63/62	80/80	65/64	370/370	67/66	80/80	70/69	374/374	68/67	80/80	71/70	375/375	71/71	80/80	75/74	379/379	
		112A	24.0/32.0	66.7/77.0	95/106	100/110	87/98	370/370	99/111	100/125	91/102	374/374	101/112	110/125	92/103	375/375	105/117	110/125	96/107	379/379	
		112A+117A	31.8/42.4	88.4/102.0	122/138	125/150	112/126	370/370	126/142	150/150	116/131	374/374	128/144	150/150	117/132	375/375	132/148	150/150	121/136	379/379	
		112A+110A	37.6/50.0	104.2/120.3	141/131	150/150	130/147	370/370	146/135	150/150	134/152	374/374	147/137	150/150	135/153	375/375	152/141	175/150	140/157	379/379	
	MED	NONE	-	-	65/64	80/80	68/67	394	69/68	80/80	72/71	398	70/69	80/80	73/72	399	74/73	80/80	78/77	403	
		117A	7.8/10.4	21.7/25.0	65/64	80/80	68/67	394/394	69/68	80/80	72/71	398/398	70/69	80/80	73/72	399/399	74/73	80/80	78/77	403/403	
		110A	12.0/16.0	33.4/38.5	65/64	80/80	68/67	394/394	69/68	80/80	72/71	398/398	70/69	80/80	73/72	399/399	74/73	80/80	78/77	403/403	
		112A	24.0/32.0	66.7/77.0	97/109	100/110	89/100	394/394	102/114	110/125	93/104	398/398	103/115	110/125	95/105	399/399	108/120	110/125	99/110	403/403	
		112A+117A	31.8/42.4	88.4/102.0	124/140	125/150	114/129	394/394	129/145	150/150	118/133	398/398	130/146	150/150	120/134	399/399	135/151	150/175	124/138	403/403	
		112A+110A	37.6/50.0	104.2/120.3	144/133	150/150	132/150	394/394	149/138	150/150	137/154	398/398	150/139	150/150	138/155	399/399	155/144	175/175	142/160	403/403	
	HIGH	NONE	-	-	68/67	80/80	71/70	405	72/71	80/80	75/74	409	73/72	80/80	77/76	410	76/76	90/90	81/80	414	
		117A	7.8/10.4	21.7/25.0	68/67	80/80	71/70	405/405	72/71	80/80	75/74	409/409	73/72	80/80	77/76	410/410	76/76	90/90	81/80	414/414	
		110A	12.0/16.0	33.4/38.5	68/67	80/80	71/70	405/405	72/71	80/80	75/74	409/409	73/72	80/80	77/76	410/410	76/76	90/90	81/80	414/414	
		112A	24.0/32.0	66.7/77.0	101/113	110/125	92/103	405/405	106/117	110/125	97/108	409/409	107/119	110/125	98/109	410/410	112/123	125/125	102/113	414/414	
		112A+117A	31.8/42.4	88.4/102.0	128/144	150/150	117/132	405/405	133/149	150/150	122/136	409/409	134/150	150/150	123/137	410/410	139/155	150/175	127/142	414/414	
		112A+110A	37.6/50.0	104.2/120.3	148/137	150/150	135/153	405/405	152/141	175/175	140/157	409/409	154/143	175/175	141/158	410/410	158/147	175/175	145/163	414/414	
558J-14D (2-Circuit / 2-Stage Cooling)	STD	NONE	-	-	29	35	30	184	31	40	32	186	31	40	32	186	33	40	34	188	
		116B	13.9	16.7	29	35	30	184	31	40	32	186	31	40	32	186	33	40	34	188	
		113B	16.5	19.8	30	35	30	184	32	40	32	186	33	40	32	186	35	40	34	188	
		115B	33.0	39.7	55	60	50	184	57	60	52	186	58	60	53	186	60	60	55	188	
		128B	41.7	50.2	68	70	62	184	70	70	64	186	71	80	65	186	73	80	67	188	
		129B	50.0	60.1	65	70	73	184	68	80	76	186	68	80	76	186	70	80	78	188	
	MED	NONE	-	-	30	40	31	196	32	40	33	198	32	40	33	198	34	40	35	200	
		116B	13.9	16.7	30	40	31	196	32	40	33	198	32	40	33	198	34	40	35	200	
		113B	16.5	19.8	31	40	31	196	34	40	33	198	34	40	33	198	36	40	35	200	
		115B	33.0	39.7	56	60	51	196	58	60	53	198	59	60	54	198	61	70	56	200	
		128B	41.7	50.2	69	70	63	196	72	80	65	198	72	80	66	198	74	80	68	200	
		129B	50.0	60.1	67	80	75	196	69	80	77	198	69	80	77	198	72	80	79	200	
	HIGH	NONE	-	-	31	40	33	201	33	40	35	203	34	40	35	203	35	45	37	205	
		116B	13.9	16.7	31	40	33	201	33	40	35	203	34	40	35	203	35	45	37	205	
		113B	16.5	19.8	33	40	33	201	35	40	35	203	36	40	35	203	38	45	37	205	
		115B	33.0	39.7	58	60	53	201	60	60	55	203	61	70	56	203	63	70	58	205	
		128B	41.7	50.2	71	80	65	201	73	80	67	203	74	80	68	203	76	80	70	205	
		129B	50.0	60.1	69	80	76	201	71	80	79	203	71	80	79	203	74	80	81	205	
575-3-60	STD	NONE	-	-	24	30	24	147	27	30	29	151	25	30	26	149	29	35	31	153	
		118A	18.0	17.3	28	30	25	147	32	35	29	151	30	30	27	149	35	35	31	153	
		119A	36.0	34.6	49	50	45	147	54	60	49	151	51	60	47	149	56	60	51	153	
		118A+119A	54.0	52.0	58	60	65	147	63	70	69	151	60	70	67	149	65	70	71	153	
	MED	NONE	-	-	24	30	24	147	27	30	29	151	25	30	26	149	29	35	31	153	
		118A	18.0	17.3	28	30	25	147	32	35	29	151	30	30	27	149	35	35	31	153	
		119A	36.0	34.6	49	50	45	147	54	60	49	151	51	60	47	149	56	60	51	153	
		118A+119A	54.0	52.0	58	60	65	147	63	70	69	151	60	70	67	149	65	70	71	153	
	HIGH	NONE	-	-	25	30	26	161	29	35	31	165	27	30	28	163	31	35	33	167	
		118A	18.0	17.3	30	30	27	161	35	35	31	165	32	35	29	163	37	40	33	167	
		119A	36.0	34.6	51	60	47	161	56	60	51	165	54	60	49	163	58	60	53	167	
		118A+119A	54.0	52.0	60	70	67	161	65	70	71	165	62	70	69	163	67	70	73	167	

See Legend and Notes on page 54.

**UNIT WIRE/FUSE OR HACR BREAKER SIZING DATA -
2-SPEED INDOOR FAN MOTOR, 6-15 TONS (CONT)**

SIZE/STAGE	NOM. V/Ph-Hz	IFM TYPE	ELECTRIC HEATER			NO CONVENIENCE OUTLET (C.O.) or UNPWR C.O.								w/ PWRD C.O.							
			CRHEATER ***A00	Nom (kW)	FLA	NO Power Exhaust (P.E.)				w/ P.E. (pwrd fr/ unit)				NO P.E.				w/ P.E. (pwrd fr/ unit)			
						MCA	Fuse or Hacr Brkr	DISC. SIZE		MCA	Fuse or Hacr Brkr	DISC. SIZE		MCA	Fuse or Hacr Brkr	DISC. SIZE		MCA	Fuse or Hacr Brkr	DISC. SIZE	
								FLA	LRA			FLA	LRA			FLA	LRA			FLA	LRA
208/230-3-60		STD	NONE	-	-	70/69	80/80	73/72	393	74/73	80/80	77/76	397	75/74	90/80	78/77	398	78/78	100/100	82/82	402
			291A	12.4/16.5	34.4/39.7	70/69	80/80	73/72	393/393	74/73	80/80	77/76	397/397	75/74	90/80	78/77	398/398	78/78	100/100	82/82	402/402
			294A	25.2/33.5	69.9/80.6	99/111	100/125	90/102	393/393	103/116	110/125	95/106	397/397	105/117	110/125	96/107	398/398	109/122	110/125	100/112	402/402
			288A+294A	32.7/43.5	90.7/104.7	125/141	125/150	114/129	393/393	129/146	150/150	119/134	397/397	131/147	150/150	120/135	398/398	135/152	150/175	124/139	402/402
			291A+294A	37.6/50.0	104.3/120.3	142/131	150/150	130/147	393/393	146/135	150/150	134/152	397/397	148/137	150/150	135/153	398/398	152/141	175/150	140/157	402/402
			294A+294A	50.3/67.0	139.7/161.2	151/171	175/200	171/194	393/393	156/176	175/200	175/199	397/397	157/177	175/200	176/200	398/398	162/182	175/200	180/204	402/402
		MED	NONE	-	-	72/71	80/80	75/74	417	417	76/75	100/90	421	77/76	100/100	81/79	422	81/80	100/100	85/84	426
			291A	12.4/16.5	34.4/39.7	72/71	80/80	75/74	417/417	76/75	100/90	79/78	421/421	77/76	100/100	81/79	422/422	81/80	100/100	85/84	426/426
			294A	25.2/33.5	69.9/80.6	101/113	110/125	93/104	417/417	106/118	110/125	97/108	421/421	107/119	110/125	98/109	422/422	112/124	125/125	103/114	426/426
			288A+294A	32.7/43.5	90.7/104.7	127/144	150/150	117/132	417/417	132/148	150/150	121/136	421/421	133/150	150/150	122/137	422/422	138/154	150/175	127/142	426/426
			291A+294A	37.6/50.0	104.3/120.3	144/133	150/150	132/150	417/417	149/138	150/150	137/154	421/421	150/139	150/150	138/155	422/422	155/144	175/175	142/160	426/426
			294A+294A	50.3/67.0	139.7/161.2	154/174	175/200	173/197	417/417	158/179	175/200	177/201	421/421	160/180	175/200	179/202	422/422	164/185	175/200	183/207	426/426
		HIGH	NONE	-	-	82	100	86	432	85	100	91	436	86	100	92	437	90	100	96	441
			291A	12.4/16.5	34.4/39.7	82/82	100/100	86/86	432/432	85/85	100/100	91/91	436/436	86/86	100/100	92/92	437/437	90/90	100/100	96/96	441/441
			294A	25.2/33.5	69.9/80.6	113/127	125/150	104/116	432/432	118/131	125/150	108/121	436/436	119/133	125/150	109/122	437/437	124/137	125/150	114/126	441/441
			288A+294A	32.7/43.5	90.7/104.7	139/157	150/175	128/144	432/432	144/162	150/175	132/148	436/436	145/163	150/175	133/149	437/437	150/168	150/175	138/154	441/441
			291A+294A	37.6/50.0	104.3/120.3	156/146	175/175	143/162	432/432	161/151	175/175	148/166	436/436	162/152	175/175	149/167	437/437	167/157	175/175	153/172	441/441
			294A+294A	50.3/67.0	139.7/161.2	166/187	175/225	184/209	432/432	170/192	175/225	188/213	436/436	172/193	200/225	190/214	437/437	176/198	200/225	194/219	441/441
460-3-60		STD	NONE	-	-	35	45	36	233	37	45	38	235	37	45	38	235	39	50	40	237
			292A	16.5	19.9	35	45	36	233	37	45	38	235	37	45	38	235	39	50	40	237
			295A	33.5	40.3	56	60	51	233	58	60	53	235	58	60	53	235	61	70	55	237
			289A+295A	43.5	52.3	71	80	65	233	73	80	67	235	73	80	67	235	76	80	69	237
			292A+295A	50.0	60.2	65	70	74	233	68	80	76	235	68	80	76	235	70	80	78	237
			295A+295A	67.0	80.6	86	90	97	233	88	100	99	235	89	100	100	235	91	100	102	237
		MED	NONE	-	-	36	45	37	245	38	50	39	247	38	50	40	247	40	50	42	249
			292A	16.5	19.9	36	45	37	245	38	50	39	247	38	50	40	247	40	50	42	249
			295A	33.5	40.3	57	60	52	245	59	60	54	247	60	60	55	247	62	70	57	249
			289A+295A	43.5	52.3	72	80	66	245	74	80	68	247	75	80	68	247	77	80	70	249
			292A+295A	50.0	60.2	67	80	75	245	69	80	77	247	70	80	77	247	72	80	79	249
			295A+295A	67.0	80.6	87	100	98	245	89	100	100	247	90	100	101	247	92	100	103	249
		HIGH	NONE	-	-	41	50	43	252	43	50	45	254	43	50	46	254	45	50	48	256
			292A	16.5	19.9	41	50	43	252	43	50	45	254	43	50	46	254	45	50	48	256
			295A	33.5	40.3	64	70	58	252	66	70	60	254	66	70	61	254	69	70	63	256
			289A+295A	43.5	52.3	79	80	72	252	81	90	74	254	81	90	74	254	84	90	76	256
			292A+295A	50.0	60.2	73	80	81	252	76	80	83	254	76	80	83	254	78	80	86	256
			295A+295A	67.0	80.6	94	100	104	252	96	100	106	254	97	100	107	254	99	100	109	256
575-3-60		STD	NONE	-	-	29	35	30	184	32	40	34	188	30	35	32	186	34	40	36	190
			293A	16.5	15.9	29	35	30	184	32	40	34	188	30	35	32	186	34	40	36	190
			296A	33.5	32.2	46	50	42	184	51	60	47	188	48	50	44	186	53	60	49	190
			290A+296A	43.5	41.9	58	60	53	184	63	70	58	188	61	70	55	186	65	70	60	190
			293A+296A	50.0	48.1	54	60	60	184	59	60	65	188	56	60	62	186	61	70	67	190
			296A+296A	67.0	64.5	71	80	79	184	75	80	84	188	73	80	81	186	77	80	86	190
		MED	NONE	-	-	29	35	30	184	32	40	34	188	30	35	32	186	34	40	36	190
			293A	16.5	15.9	29	35	30	184	32	40	34	188	30	35	32	186	34	40	36	190
			296A	33.5	32.2	46	50	42	184	51	60	47	188	48	50	44	186	53	60	49	190
			290A+296A	43.5	41.9	58	60	53	184	63	70	58	188	61	70	55	186	65	70	60	190
			293A+296A	50.0	48.1	54	60	60	184	59	60	65	188	56	60	62	186	61	70	67	190
			296A+296A	67.0	64.5	71	80	79	184	75	80	84	188	73	80	81	186	77	80	86	190
		HIGH	NONE	-	-	33	40	35	196	37	45	39	200	35	40	37	198	39	45	41	202
			293A	16.5	15.9	33	40	35	196	37	45	39	200	35	40	37	198	39	45	41	202
			296A	33.5	32.2	52	60	47	196	57	60	52	200	54	60	49	198	59	60	54	202
			290A+296A	43.5	41.9	64	70	59	196	69	70	63	200	66	70	60	198	71	80	65	202
			293A+296A	50.0	48.1	60	70	66	196	65	70	70	200	62	70	68	198	67	70	72	202
			296A+296A	67.0	64.5	76	80	85	196	81	90	89	200	78	80	86	198	83	90	91	202

See Legend and Notes on page 54.

CONTROLS

Sequence of Operation

General

The sequence below describes the sequence of operation for an electro-mechanical unit with and without a factory-installed EconoMiSer® IV and X (called “economizer” in this sequence). For information regarding a direct digital controller, see the start-up, operations, and troubleshooting manual for the applicable controller.

Electro-mechanical units with no economizer

Cooling (Single speed indoor fan motor) — When the thermostat calls for cooling, terminals G and Y1 are energized. As a result, the indoor fan contactor (IFC) and the compressor contactor (C1) are energized, causing the indoor fan motor (IFM), compressor #1, and outdoor fan to start. If the unit has 2 stages of cooling, the thermostat will additionally energize Y2. The Y2 signal will energize compressor contactor #2 (C2), causing compressor #2 to start. Regardless of the number of stages, the outdoor fan motor runs continuously while unit is cooling. When the 2-speed indoor fan motor system is utilized the indoor fan motor runs at design CFM (full speed) during the heating operation.

On 1-circuit/2-stage cooling model from 7.5 to 10 ton, 2-speed fan motor system is not available. Efficiencies to meet the U.S. Department of Energy - 2018 IEER efficiency rating are achieved by using a precision 2-stage compressor operation sequencing with one indoor fan motor speed.

Cooling (2-speed indoor fan motor) — Per ASHRAE 90.1-2016 standard, during the first stage of cooling operation the 2-speed indoor fan motor system will adjust the fan motor to provide 66% of the total cfm established for the unit. When a call for the second stage of cooling is required, the 2-speed fan motor system will allow the total cfm for the unit established (100%). This is standard on all U.S. installed models with 2 circuit/2 stage cooling, to meet U.S. Department of Energy - 2018 IEER efficiency rating.

Bryant’s 2-speed indoor fan motor system automatically adjusts the indoor fan motor speed in sequence with the units cooling operation. Per ASHRAE 90.1-2016 standard, during the first stage of cooling operation, the 2-speed controller will adjust the fan motor to provide 66% of the total cfm established for the unit. When a call for the second stage of cooling is required, the 2-speed fan motor controller will allow the total cfm for the unit established (100%). During the heating mode, the 2-speed fan controller will allow total design cfm (100%) operation and during the ventilation mode, will allow operation to 66% of total cfm.

Heating (Single or 2-speed indoor fan motor)

NOTE: Legacy Line (558J) units are sold as cooling only. If electric heaters are required; use only factory-approved electric heaters. They will operated as described below.

Units have either 1 or 2 stages of electric heat. When the thermostat calls for heating, power is applied to the W1 terminal at the unit. The unit control will energize the indoor fan contactor and the first stage of electric heat. On units with 2-stage heating, when additional heating is required, the second stage of electric heat (if equipped) will be energized when power is applied at the W2 terminal on the unit.

Electro-mechanical units with an economizer -cooling

— When free cooling is not available, the compressors will be controlled by the zone thermostat. When free cooling is available, the outdoor-air damper is modulated by the EconoMiSer® IV and X control to provide a 50°F (10°C) to 55°F (13°C) mixed-air temperature into the zone. As the mixed air temperature fluctuates above 55°F (13°C) or below 50°F (10°C) dampers will be modulated (open or close) to bring the mixed-air temperature back within control. If mechanical cooling is utilized with free cooling, the outdoor-air damper will maintain its current position at the time the compressor is started. If the increase in cooling capacity causes the mixed-air temperature to drop below 45°F (7°C), then the outdoor-air damper position will be decreased to the minimum position. If the mixed-air temperature continues to fall, the outdoor-air damper will close. Control returns to normal once the mixed-air temperature rises above 48°F (9°C). The power exhaust fans will be energized and de-energized, if installed, as the outdoor-air damper opens and closes.

If field-installed accessory CO₂ sensors are connected to the EconoMiSer IV and X control, a demand controlled ventilation strategy will begin to operate. As the CO₂ level in the zone increases above the CO₂ setpoint, the minimum position of the damper will be increased proportionally. As the CO₂ level decreases because of the increase in fresh air, the outdoor-air damper will be proportionally closed. For EconoMiSer IV and X operation, there must be a thermostat call for the fan (G). If the unit is occupied and the fan is on, the damper will operate at minimum position. Otherwise, the damper will be closed.

When the EconoMiSer IV and X control is in the occupied mode and a call for cooling exists (Y1 on the thermostat), the control will first check for indoor fan operation. If the fan is not on, then cooling will not be activated. If the fan is on, then the control will open the EconoMiSer IV and X damper to the minimum position.

On the initial power to the EconoMiSer IV and X control, it will take the damper up to 2 1/2 minutes before it begins to position itself. After the initial power-up, further changes in damper position can take up to 30 seconds to initiate. Damper movement from full closed to full open (or vice versa) will take between 1 1/2 and 2 1/2 minutes. If free cooling can be used as determined from the appropriate changeover command (switch, dry bulb, enthalpy curve, differential dry bulb, or differential enthalpy), then the control will modulate the dampers open to maintain the mixed air temperature setpoint at 50°F (10°C) to 55°F (13°C). If there is a further demand for cooling (cooling second stage - Y2 is energized), then the control will bring on compressor stage 1 to maintain the mixed air temperature setpoint. The EconoMiSer IV and X damper will be open at maximum position.

2-Speed NOTE: When operating in ventilation mode only, the indoor fan motor will automatically adjust to 66% of the total cfm established.

Heating — The sequence of operation for the heating is the same as an electro-mechanical unit with no economizer. The only difference is how the economizer acts. The economizer will stay at the Economizer Minimum Position while the evaporator fan is operating. The outdoor-air damper is closed when the indoor fan is not operating. Refer to Service and Maintenance Manual for further details.

Optional Perfect Humidity™ dehumidification system

Units with the factory equipped Perfect Humidity option are capable of providing multiple modes of improved dehumidification as a variation of the normal cooling cycle. The Perfect Humidity option includes additional valves in the liquid line and discharge line of each refrigerant circuit, a small reheat condenser coil downstream of the evaporator, and Motormaster® variable-speed control of some or all outdoor fans. Operation of the revised refrigerant circuit for each mode is described below.

The Perfect Humidity system provides three sub-modes of operation: Cool, Reheat1, and Reheat2.

- Cool mode - provides a normal ratio of Sensible and Latent Cooling effect from the evaporator coil.
- Reheat1 - provides increased Latent Cooling while slightly reducing the Sensible Cooling effect.
- Reheat2 - provides normal Latent Cooling but with null or minimum Sensible Cooling effect delivered to the space.

The Reheat1 and Reheat2 modes are a variable when the unit is not in a Heating mode and when the Low Ambient Lockout switch is closed. The following diagrams depict piping for Single Stage cooling units.

CONTROLS (CONT)

NORMAL COOLING MODE — PERFECT HUMIDITY™ SYSTEM

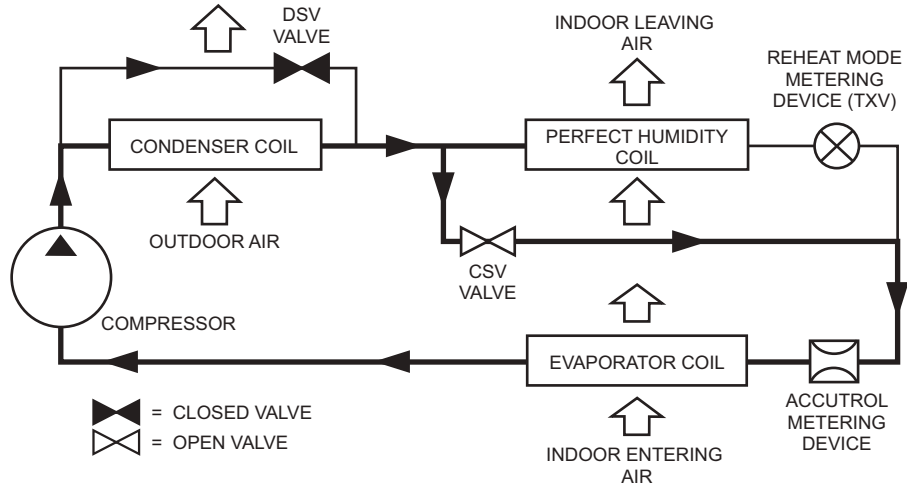

SUBCOOLING MODE (REHEAT 1) — PERFECT HUMIDITY SYSTEM

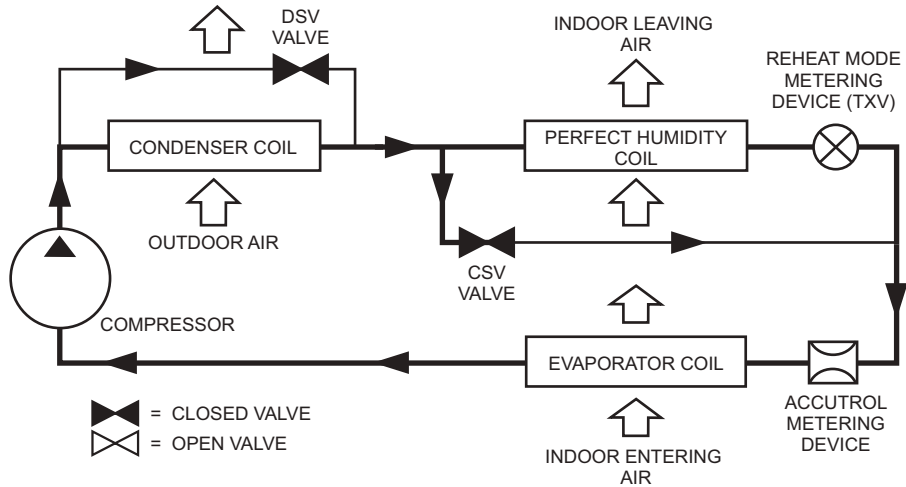

SUBCOOLING MODE (REHEAT 2) — PERFECT HUMIDITY SYSTEM

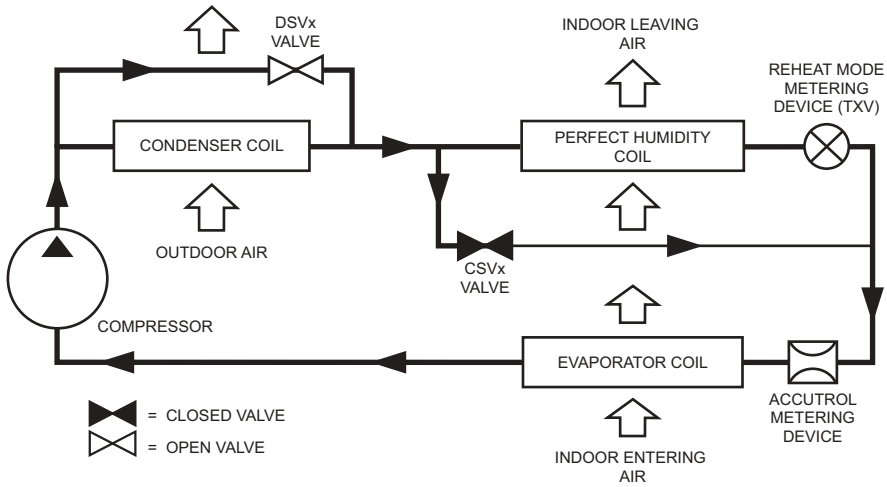

GUIDE SPECIFICATIONS — 558J*07-16 UNITS

Note about this specification: These specifications are written in “Masterformat” as published by the Construction Specification Institute. Please feel free to copy this specification directly into your building spec.

Legacy™ Line

Cooling only/electric heat packaged rooftop

HVAC guide specifications

Size range: **6 to 15 Nominal Tons**

Bryant Model Number: **558J*07-16**

Part 1 — (23 06 80) Schedules for decentralized HVAC equipment

1.01 (23 06 80.13) Decentralized Unitary HVAC Equipment Schedule

- A. (23 06 80.13.A.) Rooftop unit (RTU) schedule
 - 1. Schedule is per the project specification requirements.

Part 2 — (23 07 16) HVAC equipment installation

2.01 (23 07 16.13) Decentralized rooftop units:

- A. (23 07 16.13.A.) Evaporator fan compartment:
 - 1. Interior cabinet surfaces shall be insulated with a minimum 1/2-in. thick, minimum 1 1/2-lb density, flexible fiberglass insulation bonded with a phenolic binder, neoprene coated on the air side.
 - 2. Insulation and adhesive shall meet NFPA 90A requirements for flame spread and smoke generation.
 - 3. Unit internal insulation linings shall be resistant to mold growth in accordance with “mold growth and humidity” test in ASTM C1338, G21, and UL 181 or comparable test method. Air stream surfaces shall be evaluated in accordance with the “Erosion Test” in UL 181, as part of ASTM C1071.
- B. (23 07 16.13.B.) Electric heat compartment:
 - 1. Aluminum foil-faced fiberglass insulation shall be used.
 - 2. Insulation and adhesive shall meet NFPA 90A requirements for flame spread and smoke generation.

Part 3 — (23 07 13) Instrumentation and control devices for HVAC

3.01 (23 07 13.23) Sensors and transmitters

- A. (23 07 13.23.A.) Thermostats
 - 1. Thermostats must:
 - a. Energize both "W" and "G" when calling for heat.
 - b. Have capability to energize 2 different stages of cooling, and 2 different stages of heating.
 - c. Include capability for occupancy scheduling.

Part 4 — (23 09 23) Direct-digital control system for HVAC

4.01 (23 09 23.13) Decentralized, Rooftop Units:

- A. (23 09 23.13.B.) RTU Open protocol, direct digital controller:
 - 1. Shall be ASHRAE 62 compliant.

- 2. RTU Open controls meets California Title 24 Section 120.2i, ASHRAE 90.1-2016 and IECC-2015 Fault Detection and Diagnostic (FDD) requirements.
- 3. Shall accept 18-30VAC, 50-60Hz, and consume 15VA or less power.
- 4. Shall have an operating temperature range from –40°F (–40°C) to 130°F (54°C), 10% to 90% RH (non-condensing).
- 5. Shall include built-in protocol for BACnet¹ (MS/TP and PTP modes), Modbus² (RTU and ASCII), Johnson N2 and LonWorks³. LonWorks Echelon processor required for all Lon applications shall be contained in separate communication board.
- 6. Shall allow access of up to 62 network variables (SNVT). Shall be compatible with all open controllers.
- 7. Baud rate Controller shall be selectable using a dip switch.
- 8. Shall have an LED display independently showing the status of serial communication, running, errors, power, all digital outputs, and all analog inputs.
- 9. Shall accept the following inputs: space temperature, setpoint adjustment, outdoor air temperature, indoor air quality, outdoor air quality, compressor lock-out, fire shutdown, enthalpy switch, and fan status / filter status / humidity / remote occupancy.
- 10. Shall provide the following outputs: economizer, variable frequency drive, fan, cooling stage 1, cooling stage 2, heat stage 1, heat stage 2, exhaust/reversing valve.
- 11. Shall have built-in surge protection circuitry through solid-state polyswitches. Polyswitches shall be used on incoming power and network connections. Polyswitches will return to normal when the ‘trip’ condition clears.
- 12. Shall have a battery backup capable of a minimum of 10,000 hours of data and time clock retention during power outages.
- 13. Shall have built-in support for Bryant technician tool.
- 14. Shall include an RS-485 protocol communication port, an access port for connection of either a computer or a Bryant technician tool, an RS-485 port for network communication to intelligent space sensors and displays, and a port to connect an optional LonWorks communications card.
- 15. Software upgrades will be accomplished by either local or remote download. No software upgrades through chip replacements are allowed.

1. BACnet is a registered trademark of ASHRAE (American Society of Heating, Refrigerating and Air-Conditioning Engineers).
2. Modbus is a registered trademark of Schneider Electric.
3. LonWorks is a registered trademark of Echelon Corporation.

GUIDE SPECIFICATIONS — 558J*07-16 UNITS (CONT)

Part 5 — (23 09 33) Electric and electronic control system for HVAC

5.01 (23 09 33.13) Decentralized, rooftop units

A. (23 09 33.13.A.) General:

1. Shall be complete with self-contained low-voltage control circuit protected by a resettable circuit breaker on the 24-v transformer side. Transformer shall have 75VA capability.
2. Shall utilize color-coded wiring.
3. Shall include a central control terminal board to conveniently and safely provide connection points for vital control functions such as: smoke detectors, phase monitor, economizer, thermostat, DDC control options, and low and high pressure switches.
4. Unit shall include a minimum of one 8-pin screw terminal connection board for connection of control wiring.

B. (23 09 33.13.B.) Safeties:

1. Compressor over-temperature, over-current. High internal pressure differential.
2. Low-pressure switch.
 - a. Units shall have different sized connectors for the circuit 1 and circuit 2 low and high pressure switches. They shall physically prevent the cross-wiring of the safety switches between circuits 1 and 2.
 - b. Low-pressure switch shall use different color wire than the high-pressure switch. The purpose is to assist the installer and service technician to correctly wire and or troubleshoot the rooftop unit.
3. High-pressure switch.
 - a. Units shall have different sized connectors for the circuit 1 and circuit 2 low and high-pressure switches. They shall physically prevent the cross-wiring of the safety switches between circuits 1 and 2.
 - b. High-pressure switch shall use different color wire than the low-pressure switch. The purpose is to assist the installer and service technician to correctly wire and or troubleshoot the rooftop unit.
4. Automatic reset, motor thermal overload protector.

Part 6 — (23 09 93) Sequence of operations for HVAC controls

6.01 (23 09 93.13) Decentralized, Rooftop Units:

A. (23 09 93.13.A.) INSERT SEQUENCE OF OPERATION

Part 7 — (23 40 13) Panel air filters

7.01 (23 40 13 13) Decentralized rooftop units:

A. (23 40 13 13.A.) Standard filter section

1. Shall consist of factory-installed, low velocity, disposable 2-in. thick fiberglass filters of commercially available sizes.

2. Unit shall use only one filter size. Multiple sizes are not acceptable.
3. Filters shall be accessible through a dedicated, weather tight access panel with 'no-tool' removal as described in the unit cabinet section of this specification.

Part 8 — (23 81 19) Self-contained air conditioners

8.01 (23 81 19.13) Small-Capacity Self-Contained Air Conditioners (558J*07-16)

A. (23 81 19.13.A.) General

1. Outdoor, rooftop mounted, electrically controlled, heating and cooling unit utilizing a fully hermetic scroll compressor(s) for cooling and heating duty.
2. Factory assembled, single-piece heating and cooling rooftop unit. Contained within the unit enclosure shall be all factory wiring, piping, controls, and special features required prior to field start-up.
3. Unit shall use Puron® (R-410A) refrigerant.
4. Unit shall be installed in accordance with the manufacturer's instructions.
5. Unit must be selected and installed in compliance with local, state, and federal codes.

B. (23 81 19.13.B.) Quality Assurance

1. Unit meets Department of Energy 2018, ASHRAE 90.1-2016 and IECC¹-2015 standards.
2. Unit shall be rated in accordance with AHRI Standards 340/360.
3. Unit shall be designed to conform to ASHRAE 15.
4. Unit shall be UL-tested and certified in accordance with ANSI Z21.47 Standards and UL-listed and certified under Canadian standards as a total package for safety requirements.
5. Insulation and adhesive shall meet NFPA 90A requirements for flame spread and smoke generation.
6. Unit casing shall be capable of withstanding 500-hour salt spray exposure per ASTM B117 (scribed specimen).
7. Roof curb shall be designed to conform to NRCA Standards.
8. Unit shall be subjected to a completely automated run test on the assembly line. The data for each unit will be stored at the factory, and must be available upon request.
9. Unit shall be designed in accordance with UL Standard 1995, ETL listed including tested to withstand rain.
10. Unit shall be constructed to prevent intrusion of snow and tested to prevent snow intrusion into the control box up to 40 mph.
11. Unit shake tested to assurance level 1, ASTM D4169 to ensure shipping reliability.

1. IECC is a registered trademark of International Code Council, Inc.

12. High Efficiency Motors listed shall meet section 313 of the Energy Independence and Security Act of 2007 (EISA 2007).
- C. (23 81 19.13.C.) Delivery, storage, and handling
 1. Unit shall be stored and handled per manufacturer's recommendations.
 2. Lifted by crane requires either shipping top panel or spreader bars.
 3. Unit shall only be stored or positioned in the upright position.
- D. (23 81 19.13.D.) Project conditions:
 1. As specified in the contract.
- E. (23 81 19.13.E.) Operating characteristics
 1. Unit shall be capable of starting and running at 115°F (46°C) ambient outdoor temperature, meeting maximum load criteria of AHRI Standard 340/360 at ± 10% voltage.
 2. Compressor with standard controls shall be capable of operation down to 40°F (4°C), ambient outdoor temperatures. Accessory winter start kit is necessary if mechanically cooling at ambient temperatures below 25°F (-4°C).
 3. Unit shall be field convertible from factory furnished vertical to horizontal airflow on all models. No special kit required on 07-14 models. Supply duct kit required for 16 size model only.
 4. Unit shall be capable of field mixed operation: vertical supply with horizontal return or horizontal supply with vertical return.
- F. (23 81 19.13.F.) Electrical Requirements
 1. Main power supply voltage, phase, and frequency must match those required by the manufacturer.
- G. (23 81 19.13.G.) Unit cabinet
 1. Unit cabinet shall be constructed of galvanized steel, and shall be bonderized and coated with a pre-painted baked enamel finish on all externally exposed surfaces.
 2. Unit cabinet exterior paint shall be: film thickness, (dry) 0.003 inches minimum, gloss (per ASTM D523, 60°F/16°C): 60, Hardness: H to 2H Pencil hardness.
 3. Evaporator fan compartment interior cabinet insulation shall conform to AHRI Standards 340/360 minimum exterior sweat criteria. Interior surfaces shall be insulated with a minimum 1/2-in. thick, 1-lb density, flexible fiberglass insulation, neoprene coated on the air side. Aluminum foil-faced fiberglass insulation shall be used in the heat compartment.
 4. Base of unit shall have a minimum of four locations for thru-the-base electrical connections standard.
 5. Base rail:
 - a. Unit shall have base rails on a minimum of 2 sides.
 - b. Holes shall be provided in the base rails for rigging shackles to facilitate maneuvering and overhead rigging.
 - c. Holes shall be provided in the base rail for moving the rooftop by fork truck.
 - d. Base rail shall be a minimum of 16-gauge thickness.
6. Condensate pan and connections:
 - a. Shall be a sloped condensate drain pan made of a non-corrosive material.
 - b. Shall comply with ASHRAE Standard 62.
 - c. Shall use a 3/4-in. to 14 NPT drain connection, through the side of the drain pan. Connection shall be made per manufacturer's recommendations.
7. Top panel:
 - a. Shall be a single piece top panel on 07 thru 12 sizes, two piece on 14 and 16 sizes.
8. Electrical connections:
 - a. All unit power wiring shall enter unit cabinet at a single, factory-prepared, knockout location.
 - b. Thru-the-base capability.
 - 1) Thru-the-base provisions / connections are available as standard with every unit. When bottom connections are required, field furnished couplings are required.
 - 2) Optional, factory approved, water-tight connection method must be used for thru-the-base electrical connections.
 - 3) No basepan penetration, other than those authorized by the manufacturer, is permitted.
9. Component access panels (standard):
 - a. Cabinet panels shall be easily removable for servicing.
 - b. Unit shall have one factory-installed, removable, tool-less filter access panel.
 - c. Panels covering control box and filter shall have molded composite handles while the blower access door shall have an integrated flange for easy removal.
 - d. Handles shall be UV modified, composite. They shall be permanently attached, and recessed into the panel.
 - e. Screws on the vertical portion of all removable access panel shall engage into heat resistant, molded composite collars.
 - f. Collars shall be removable and easily replaceable using manufacturer recommended parts.
- H. (23 81 19.13.H.) Coils
 1. Standard aluminum fin/copper tube coils:
 - a. Standard evaporator and condenser coils shall have aluminum lanced plate fins mechanically bonded to seamless internally grooved copper tubes with all joints brazed.

GUIDE SPECIFICATIONS — 558J*07-16 UNITS (CONT)

- b. Evaporator coils shall be leak tested to 150 psig, pressure tested to 450 psig, and qualified to UL 1995 burst test at 1775 psig.
 - c. Condenser coils shall be leak tested to 150 psig, pressure tested to 650 psig, and qualified to UL 1995 burst test at 1980 psig.
 2. Optional pre-coated aluminum-fin condenser coils:
 - a. Shall have a durable epoxy-phenolic coating to provide protection in mildly corrosive coastal environments.
 - b. Coating shall be applied to the aluminum fin stock prior to the fin stamping process to create an inert barrier between the aluminum fin and copper tube.
 - c. Epoxy-phenolic barrier shall minimize galvanic action between dissimilar metals.
 3. Optional copper-fin evaporator and condenser coils:
 - a. Shall be constructed of copper fins mechanically bonded to copper tubes and copper tube sheets.
 - b. Galvanized steel tube sheets shall not be acceptable.
 - c. A polymer strip shall prevent coil assembly from contacting the sheet metal coil pan to minimize potential for galvanic corrosion between coil and pan.
 4. Optional E-coated aluminum-fin, evaporator and condenser coils:
 - a. Shall have a flexible epoxy polymer coating uniformly applied to all coil surface areas without material bridging between fins.
 - b. Coating process shall ensure complete coil encapsulation of tubes, fins, and headers.
 - c. Color shall be high gloss black with gloss per ASTM D523-89.
 - d. Uniform dry film thickness from 0.8 to 1.2 mil on all surface areas including fin edges.
 - e. Superior harness characteristics of 2H per ASTM D3363-92A and cross-hatch adhesion of 4B-5B per ASTM D3359-93.
 - f. Impact resistance shall be up to 160 in.-lb (ASTM D2794-93).
 - g. Humidity and water immersion shall be up to minimum 1000 and 250 hours respectively (ASTM D2247-92 and ASTM D870-92).
 - h. Corrosion durability shall be confirmed through testing to be no less than 6000 hours salt spray per ASTM B117-90.
 5. Standard ALL Aluminum Novation® Coils (available on select models):
 - a. Standard condenser coils shall have all aluminum Novation Heat Exchanger Technology design consisting of aluminum multi-port flat tube design and aluminum fin. Coils shall be a furnace brazed design and contain epoxy lined shrink wrap on all aluminum to copper connections.
 - b. Condenser coils shall be leak tested to 150 psig, pressure tested to 650 psig, and qualified to UL 1995 burst test at 1980 psig.
 6. Optional E-coated aluminum-fin, aluminum tube condenser coils:
 - a. Shall have a flexible epoxy polymer coating uniformly applied to all coil external surface areas without material bridging between fins.
 - b. Coating process shall ensure complete coil encapsulation of tubes, fins, and headers.
 - c. E-coat thickness of 0.8 to 1.2-mil with top coat having a uniform dry film thickness from 1.0 to 2.0 mil on all external coil surface areas, including fin edges, shall be provided.
 - d. Shall have superior hardness characteristics of 2H per ASTM D3363-00 and crosshatch adhesion of 4B-5B per ASTM D3359-02.
 - e. Shall have superior impact resistance with no cracking, chipping or peeling per NSF/ANSI 51-2002 Method 10.2.
- I. (23 81 19.13.I.) Refrigerant components
1. Refrigerant circuit shall include the following control, safety, and maintenance features:
 - a. Dual circuit — two stage cooling models (08-16) shall use fixed orifice metering system shall prevent mal-distribution of two-phase refrigerant by including multiple fixed orifice devices in each refrigeration circuit. Each orifice is to be optimized to the coil circuit it serves.
 - b. Single circuit — two stage cooling models 08, 09, and 12 shall use one fixed orifice and one TXV metering device to assist in optimum latent heat removal from a single circuit design. Model 07 units use one fixed metering device.
 - c. Refrigerant filter drier - Solid core design.
 - d. Service gauge connections on suction and discharge lines.
 2. Pressure gauge access through a specially designed access port in the top panel of the unit.
 3. There shall be gauge line access port in the skin of the rooftop, covered by a black, removable plug.
 - a. The plug shall be easy to remove and replace.
 - b. When the plug is removed, the gauge access port shall enable maintenance personnel to route their pressure gauge lines.
 - c. This gauge access port shall facilitate correct and accurate condenser pressure readings by enabling the reading with the compressor access panel on.
 - d. The plug shall be made of a leak proof, UV-resistant, composite material.
 4. Compressors:
 - a. Unit shall use fully hermetic, scroll compressor for each independent refrigeration circuit.

- b. Models 08-16 with dual refrigerant circuit shall contain two scroll compressors (one per circuit), models 08, 09 and 12 with single circuit and two stage cooling shall contain one dual stage compressor. Model 07 shall contain one stage scroll compressor.
 - c. Compressor motors shall be cooled by refrigerant gas passing through motor windings.
 - d. Compressors shall be internally protected from high discharge temperature conditions.
 - e. Compressors shall be protected from an over-temperature and over-amperage conditions by an internal, motor overload device.
 - f. Compressor shall be factory-mounted on rubber grommets.
 - g. Compressor motors shall have internal line break thermal, current overload and high pressure differential protection.
 - h. Crankcase heaters shall not be required for normal operating range, unless required by the manufacturer due to refrigerant charge limits.
- J. (23 81 19.13.J.) Filter section
- 1. Filters access is specified in the unit cabinet section of this specification.
 - 2. Filters shall be held in place by a preformed, slide-out filter tray, facilitating easy removal and installation.
 - 3. Shall consist of factory-installed, low velocity, throw-away 2-in. thick fiberglass filters.
 - 4. Filters shall be standard, commercially available sizes.
 - 5. Only one size filter per unit is allowed.
- K. (23 81 19.13.K.) Evaporator fan and motor
- 1. Evaporator fan motor:
 - a. Shall have permanently lubricated bearings.
 - b. Shall have inherent automatic-reset thermal overload protection or circuit breaker.
 - c. Shall have a maximum continuous bhp rating for continuous duty operation; no safety factors above that rating shall be required.
 - 2. Belt-driven evaporator fan:
 - a. Belt drive shall include an adjustable-pitch motor pulley.
 - b. Shall use sealed, permanently lubricated ball-bearing type.
 - c. Blower fan shall be double-inlet type with forward-curved blades.
 - d. Shall be constructed from steel with a finish that aids with corrosion resistance and that is dynamically balanced.
- L. (23 81 19.13.L.) Condenser and fan motors
- 1. Condenser fan motors:
 - a. Shall be a totally enclosed motor.
 - b. Shall use permanently lubricated bearings.
 - c. Shall have inherent thermal overload protection with an automatic reset feature.
 - d. Shall use a shaft-down design on 07 to 12 and 16 models and shaft-up on 14 size with rain shield.
2. Condenser fans:
- a. Shall be a direct-driven propeller type fan.
 - b. Shall have galvalum blades riveted to steel spiders that have corrosion-resistant properties and shall be dynamically balanced.
- M. (23 81 19.13.M.) Special features options and accessories
- 1. 2-speed indoor fan motor system shall be standard on all models with dual stage cooling (and 07 size models) to meet the Department of Energy 2018 mandatory IEER efficiency requirement. Not available on models - 08, 09, 12 with single circuit - two stage cooling:
 - a. Evaporator fan motor:
 - 1) Shall have permanently lubricated bearings.
 - 2) Shall have a maximum continuous bhp rating for continuous duty operation; no safety factors above that rating.
 - 3) Shall be Variable Frequency duty and 2-speed control.
 - 4) Shall contain motor shaft grounding ring to prevent electrical bearing fluting damage by safely diverting harmful shaft voltages and bearing currents to ground.
 - 2. Variable frequency drive (VFD):
 - a. Factory-supplied VFDs qualify, through ABB, for a 12-month warranty from date of commissioning or 18 months from date of sale, whichever occurs first.
 - b. Shall be installed inside the unit cabinet, mounted, wired and tested.
 - c. Shall contain Electromagnetic Interference (EMI) frequency protection.
 - d. Insulated gate bi-polar transistors (IGBT) used to produce the output pulse width modulated (PWM) waveform, allowing for quiet motor operation.
 - e. Self-diagnostics with fault and power code LED indicator. Field accessory Display Kit available for further diagnostics and special setup applications.
 - f. RS485 capability standard.
 - g. Electronic thermal overload protection.
 - h. 5% swinging chokes for harmonic reduction and improved power factor.
 - i. All printed circuit boards shall be conformal coated.
 - 3. Integrated EconoMiSer® IV, EconoMiSer 2, and EconoMiSer X low and ultra low leak rate models:

GUIDE SPECIFICATIONS — 558J*07-16 UNITS (CONT)

- a. Integrated, gear driven opposing modulating blade design type capable of simultaneous economizer and compressor operation.
 - b. Independent modules for horizontal return configuration shall be available.
 - c. Damper blades shall be galvanized steel with composite gears. Plastic or composite blades on intake or return shall not be acceptable.
 - d. Shall include all hardware and controls to provide free cooling with outdoor air when temperature and/or humidity are below setpoints.
 - e. Shall be equipped with gear driven dampers for both the outdoor ventilation air and the return air for positive air stream control.
 - f. Low leak rate models shall be equipped with dampers not to exceed 2% leakage at 1 in. wg pressure differential.
 - g. Economizer controller on EconoMiSer® IV models shall be Honeywell W7212 that provides:
 - 1) Combined minimum and DCV maximum damper position potentiometers with compressor staging relay.
 - 2) Functions with solid state analog enthalpy or dry bulb changeover control sensing.
 - 3) Contain LED indicates for: when free cooling is available, when module is in DCV mode, when exhaust fan contact is closed.
 - h. Economizer controller on EconoMiSer® X models shall be the Honeywell W7220 that provides:
 - 1) 2-line LCD interface screen for setup, configuration and troubleshooting.
 - 2) On-board Fault Detection and Diagnostics (FDD) that senses and alerts when the economizer is not operating properly, per California Title 24.
 - 3) Sensor failure loss of communication identification.
 - 4) Automatic sensor detection.
 - 5) Capabilities for use with multiple-speed indoor fan systems.
 - 6) Utilize digital sensors: Dry bulb and Enthalpy.
 - i. Economizer controller on EconoMiSer 2 models with RTU Open models shall be 4-20mA design controlled directly by the RTU Open controller. RTU Open meets California Title 24 Fault Detection and Diagnostic (FDD) requirements.
 - j. Shall be capable of introducing up to 100% outdoor air.
 - k. Shall be equipped with a barometric relief damper capable of relieving up to 100% return air and contain seals that meet ASHRAE 90.1-2016 and IECC-2015 requirements.
 - l. Shall be designed to close damper(s) during loss-of-power situations with spring return built into motor.
 - m. Dry bulb outdoor air temperature sensor shall be provided as standard. Enthalpy sensor is also available for factory-installed economizers only. Outdoor air sensor setpoint shall be adjustable and shall range from 40 to 100°F (4 to 38°C.) Additional sensor options shall be available as accessories.
 - n. The economizer controller shall also provide control of an accessory power exhaust unit function. Factory set at 100%, with a range of 0% to 100%.
 - o. The economizer shall maintain minimum airflow into the building during occupied period and provide design ventilation rate for full occupancy.
 - p. Dampers shall be completely closed when the unit is in the unoccupied mode.
 - q. Economizer controller shall accept a 2-10 Vdc CO₂ sensor input for IAQ/DCV control. In this mode, dampers shall modulate the outdoor air damper to provide ventilation based on the sensor input.
 - r. Compressor lockout temperature on W7220 is adjustable from -45°F to 80°F (-43°C to 27°C), set at a factory default of 32°F. Others shall open at 35°F (2°C) and closes at 50°F (10°C).
 - s. Actuator shall be direct coupled to economizer gear. No linkage arms or control rods shall be acceptable.
 - t. Economizer controller shall provide indications when in free cooling mode, in the DCV mode, or the exhaust fan contact is closed.
4. Integrated EconoMiSer 2, and EconoMiSer X Ultra Low Leak rate models.
- a. Integrated, gear driven opposing modulating blade design type capable of simultaneous economizer and compressor operation.
 - b. Independent modules for horizontal return configuration shall be available. Vertical return modules shall be available as a factory-installed option.
 - c. Damper blades shall be galvanized steel with composite gears. Plastic or composite blades on intake or return shall not be acceptable.
 - d. Shall include all hardware and controls to provide free cooling with outdoor air when temperature and/or humidity are below setpoints.
 - e. Shall be equipped with gear driven dampers for both the outdoor ventilation air and the return air for positive air stream control.
 - f. Ultra Low Leak design meets California Title 24 section 140.4 and ASHRAE 90.1-2016 requirements of 4 cfm per sq ft on the outside air dampers and 10 cfm per sq ft on the return dampers. Also meets AMCA Class 1A economizer damper test standards and labeling.

- g. Economizer controller on EconoMiSer® X models shall be the Honeywell W7220 that provides:
 - 1) 2-line LCD interface screen for setup, configuration and troubleshooting.
 - 2) On-board Fault Detection and Diagnostics (FDD) that senses and alerts when the economizer is not operating properly, per California Title 24. Also meets AMCA Class 1A economizer damper test standards and labeling.
 - 3) Sensor failure loss of communication identification.
 - 4) Automatic sensor detection.
 - 5) Capabilities for use with multiple-speed indoor fan systems.
 - 6) Utilize digital sensors: Dry bulb and Enthalpy.
 - h. Economizer controller on EconoMiSer 2 models with RTU Open models shall be 4-20mA design controlled directly by the RTU Open controller. RTU Open meets California Title 24 Fault Detection and Diagnostic (FDD) requirements.
 - i. Shall be capable of introducing up to 100% outdoor air.
 - j. Shall be equipped with a barometric relief damper capable of relieving up to 100% return air and contain seals that meet ASHRAE 90.1-2016 requirements.
 - k. Shall be designed to close damper(s) during loss-of-power situations with spring return built into motor.
 - l. Dry bulb outdoor air temperature sensor shall be provided as standard. Enthalpy sensor is also available for factory-installed economizers only. Outdoor air sensor setpoint shall be adjustable and shall range from 40 to 100°F (4 to 38°C). Additional sensor options shall be available as accessories.
 - m. The economizer controller shall also provide control of an accessory power exhaust unit function. Factory set at 100%, with a range of 0% to 100%.
 - n. The economizer shall maintain minimum airflow into the building during occupied period and provide design ventilation rate for full occupancy.
 - o. Dampers shall be completely closed when the unit is in the unoccupied mode.
 - p. Economizer controller shall accept a 2-10 Vdc CO₂ sensor input for IAQ/DCV control. In this mode, dampers shall modulate the outdoor air damper to provide ventilation based on the sensor input.
 - q. Compressor lockout temperature on W7220 is adjustable from -45°F to 80°F (-43°C to 27°C), set at a factory default of 32°F (0°C). Others shall open at 35°F (2°C) and closes at 50°F (10°C).
 - r. Actuator shall be direct coupled to economizer gear. No linkage arms or control rods shall be acceptable.
 - s. Economizer controller shall provide indications when in free cooling mode, in the DCV mode, or the exhaust fan contact is closed.
5. Two-Position Motorized Damper:
- a. Damper shall be a 2-position damper. Damper travel shall be from the full closed position to the field adjustable %-open setpoint.
 - b. Damper shall include adjustable damper travel from 25% to 100% (full open).
 - c. Damper shall include single or dual blade, gear driven dampers and actuator motor.
 - d. Actuator shall be direct coupled to damper gear. No linkage arms or control rods shall be acceptable.
 - e. Damper will admit up to 100% outdoor air for applicable rooftop units.
 - f. Damper shall close upon indoor (evaporator) fan shutoff and/or loss of power.
 - g. The damper actuator shall plug into the rooftop unit's wiring harness plug. No hard wiring shall be required.
 - h. Outside air hood shall include aluminum water entrainment filter.
6. Three-Position Motorized Damper:
- a. Damper shall be a 3-position damper. Damper travel shall be from the full closed position to the field adjustable %-open setpoint. One setting to align the first stage of indoor fan motor operation, the second to align with the full stage operation of the indoor fan motor operation. The last fully closed for the off mode.
 - b. Damper shall include adjustable damper travel from 25% to 100% (full open).
 - c. Damper shall include single or dual blade, gear driven dampers and actuator motor.
 - d. Actuator shall be direct coupled to damper gear. No linkage arms or control rods shall be acceptable.
 - e. Damper will admit up to 100% outdoor air for applicable rooftop units.
 - f. Damper shall close upon indoor (evaporator) fan shutoff and/or loss of power.
 - g. The damper actuator shall plug into the rooftop unit's wiring harness plug. No hard wiring shall be required.
 - h. Outside air hood shall include aluminum water entrainment filter.
7. Manual damper:
- a. Manual damper package shall consist of damper, air inlet screen, and rain hood which can be preset to admit up to 25% or 50% outdoor air for year round ventilation.
8. Perfect Humidity™ dehumidification system:

GUIDE SPECIFICATIONS — 558J*07-16 UNITS (CONT)

- a. The Perfect Humidity Dehumidification System shall be factory-installed in 558J 07 with Perfect Humidity and dual circuit 2-stage cooling 558J 08-16 models with RTPF (round tube plate fin) condenser coils, and shall provide greater dehumidification of the occupied space by two modes of dehumidification operations in addition to its normal design cooling mode:
 - 1) Subcooling mode further sub cools the hot liquid refrigerant leaving the condenser coil when both temperature and humidity in the space are not satisfied.
 - 2) Hot gas reheat mode shall mix a portion of the hot gas from the discharge of the compressor with the hot liquid refrigerant leaving the condenser coil to create a two-phase heat transfer in the system, resulting in a neutral leaving air temperature when only humidity in the space is not satisfied.
 - 3) Includes head pressure controller.
9. Head pressure control package (Motormaster®):
 - a. Controller shall control coil head pressure by condenser-fan speed modulation or condenser-fan cycling and wind baffles.
 - b. Shall consist of solid-state control and condenser-coil temperature sensor to maintain condensing temperature between 90°F (32°C) and 110°F (43°C) at outdoor ambient temperatures down to -20°F (-29°C).
10. Condenser coil hail guard assembly (factory or field-installed):
 - a. Shall protect against damage from hail.
 - b. Shall be louvered style design.
11. Unit-mounted, non-fused disconnect switch (available on units with MOCs of 80 amps or less):
 - a. Switch shall be factory-installed, internally mounted.
 - b. National Electric Code (NEC) and UL approved non-fused switch shall provide unit power shut-off.
 - c. Shall be accessible from outside the unit.
 - d. Shall provide local shutdown and lockout capability.
 - e. Sized only for the unit as ordered from the factory. Does not accommodate field-installed devices.
12. Convenience outlet:
 - a. Powered convenience outlet:
 - 1) Outlet shall be powered from main line power to the rooftop unit.
 - 2) Outlet shall be powered from line side of disconnect by installing contractor, as required by code. If outlet is powered from load side of disconnect, unit electrical ratings shall be ETL certified and rated for additional outlet amperage.
 - 3) Outlet shall be factory-installed and internally mounted with easily accessible 115-v female receptacle.
 - 4) Outlet shall include 15 amp GFI receptacles with independent fuse protection.
 - 5) Voltage required to operate convenience outlet shall be provided by a factory-installed step-down transformer.
 - 6) Outlet shall be accessible from outside the unit.
 - 7) Outlet shall include a field-installed “Wet in Use” cover.
 - b. Factory-installed non-powered convenience outlet:
 - 1) Outlet shall be powered from a separate 115/120v power source.
 - 2) A transformer shall not be included.
 - 3) Outlet shall be factory-installed and internally mounted with easily accessible 115-v female receptacle.
 - 4) Outlet shall include 15 amp GFI receptacles with independent fuse protection.
 - 5) Outlet shall include a field-installed “Wet in Use” cover.
 - 6) Outlet shall include a field-installed “Wet in Use” cover.
 - c. Field-Installed Non-powered convenience outlet:
 - 1) Outlet shall be powered from a separate 115-120v power source.
 - 2) A transformer shall not be included.
 - 3) Outlet shall be factory-installed and internally mounted with easily accessible 115-v female receptacle.
 - 4) Outlet shall include 20 amp GFI receptacles. This kit provides a flexible installation method which allows code compliance for height requirements of the GFCI outlet from the finished roof surface as well as the capability to relocate the outlet to a more convenient location.
 - 5) Outlet shall be accessible from outside the unit.
 - 6) Outlet shall include a field-installed “Wet in Use” cover.
13. Thru-the-base connectors:
 - a. Kits shall provide connectors to permit electrical connections to be brought to the unit through the unit basepan.
 - b. Minimum of four connection locations per unit.
14. Supply duct cover: (16 size only.)
 - a. Required when field converting the factory standard vertical duct supply to horizontal duct supply configuration. One required per unit.
15. Propeller power exhaust:
 - a. Power exhaust shall be used in conjunction with an integrated economizer.
 - b. Independent modules for horizontal return configurations shall be available.

- c. Horizontal power exhaust shall be mounted in return ductwork.
 - d. Power exhaust shall be controlled by economizer controller operation. Exhaust fans shall be energized when dampers open past the 0-100% adjustable setpoint on the economizer control.
16. Roof curbs (vertical):
- a. Full perimeter roof curb with exhaust capability providing separate air streams for energy recovery from the exhaust air without supply air contamination.
 - b. Formed galvanized steel with wood nailer strip and shall be capable of supporting entire unit weight.
 - c. Permits installation and securing of ductwork to curb prior to mounting unit on the curb.
17. Outdoor air enthalpy sensor:
- a. The outdoor air enthalpy sensor shall be used to provide single enthalpy control. When used in conjunction with a return air enthalpy sensor, the unit will provide differential enthalpy control. The sensor allows the unit to determine if outside air is suitable for free cooling.
18. Return air enthalpy sensor:
- a. The return air enthalpy sensor shall be used in conjunction with an outdoor air enthalpy sensor to provide differential enthalpy control.
19. Indoor air quality (CO₂) sensor:
- a. Shall be able to provide demand ventilation indoor air quality (IAQ) control.
 - b. The IAQ sensor shall be available in duct mount, wall mount, or wall mount with LED display. The setpoint shall have adjustment capability.
20. Smoke detectors (factory-installed only):
- a. Shall be a four-wire controller and detector.
 - b. Shall be environmental compensated with differential sensing for reliable, stable, and drift-free sensitivity.
 - c. Shall use magnet-activated test/reset sensor switches.
 - d. Shall have tool-less connection terminal access.
 - e. Shall have a recessed momentary switch for testing and resetting the detector.
 - f. Controller shall include:
 - 1) One set of normally open alarm initiation contacts for connection to an initiating device circuit on a fire alarm control panel.
 - 2) Two Form-C auxiliary alarm relays for interface with rooftop unit or other equipment.
 - 3) One Form-C supervision (trouble) relay to control the operation of the Trouble LED on a remote test/reset station.
 - 4) Capable of direct connection to two individual detector modules.
- 5) Can be wired to up to 14 other duct smoke detectors for multiple fan shutdown applications.
21. Horn/strobe annunciator:
- a. Provides an audible/visual signaling device for use with factory-installed option or field-installed accessory smoke detectors.
 - 1) Requires installation of a field-supplied 24-v transformer suitable for 4.2 VA (AC) or 3.0 VA (DC) per horn/strobe accessory.
 - 2) Requires field-supplied electrical box, North American 1-gang box, 2-in. (51 mm) x 4-in. (102 mm).
 - 3) Shall have a clear colored lens.
22. Winter start kit:
- a. Shall contain a bypass device around the low pressure switch.
 - b. Shall be required when mechanical cooling is required down to 25°F (−4°C).
 - c. Shall not be required to operate on an economizer when below an outdoor ambient of 40°F (4°C).
23. Time guard:
- a. Shall prevent compressor short-cycling by providing a 5-minute delay (±2 minutes) before restarting a compressor after shutdown for any reason.
 - b. One device shall be required per compressor.
24. Electric heat:
- a. Heater element open coil resistance wire, nickel-chrome alloy, 0.29 inches inside diameter, strung through ceramic insulators mounted on metal frame. Coil ends are staked and welded to terminal screw slots.
25. Disconnect switch bracket (16 size only):
- a. Provides a pre-engineered and sized mounting bracket for applications requiring a unit mounted fused and non-fused disconnect of greater than 100 amps. Bracket assures that no damage will occur to coils when mounting with screws and other fasteners.
26. Hinged access panels:
- a. Shall provide easy access through integrated quarter-turn latches.
 - b. Shall be on major panels of: filters, control box, fan motor and compressor.
27. Display kit for variable frequency drive:
- a. Kit allows the ability to access the VFD controller programs to provide special setup capabilities and diagnostics.
 - b. Kit contains display module and communication cable.
 - c. Display kit can be permanently installed in the unit or used on any 2-speed indoor fan motor system VFD controller as needed.

GUIDE SPECIFICATIONS — 558J*07-16 UNITS (CONT)

28. Condensate overflow switch:

- a. This sensor and related controller monitors the condensate level in the drain pan and shuts down compression operation when overflow conditions occur. It includes:
 - 1) Indicator light — solid red (more than 10 seconds on water contact - compressors disabled), blinking red (sensor disconnected).
 - 2) 10 second delay to break — eliminates nuisance trips from splashing or waves in pan (sensor needs 10 seconds of constant water contact before tripping).
 - 3) Disables the compressor(s) operation when condensate plug is detected, but still allows fans to run for Economizer.

