



UP to 14.5 SEER, PACKAGE AIR CONDITIONER UNIT, 2 to 5 TONS 208/230 Volt, 1-phase, 60 Hz

REFRIGERATION CIRCUIT

- Environmentally sound R-410A refrigerant
- Liquid refrigerant filter driers
- Copper tube/aluminum fin condenser and evaporator coils

EASY TO INSTALL AND SERVICE

- Light weight, compact construction ideal for manufactured housing and residential applications
- Hand holds built into the unit base pan
- Compact, fully self-contained, electric cooling unit with horizontal supply and return ducts
- Easy panel accessibility for maintenance and installation
- Accessory electric heaters with single point connections
- Designed to be serviced from both the side and front
- Cabinet air leakage less than 2.0% at 1.0 inch W.C. and cabinet air leakage less than 1.4% at 0.5 in. W.C., when tested in accordance with ASHRAE Standard 193

BUILT TO LAST

- Vibration isolation provides quiet operation. Compressors have internal over current protection
- Direct-drive multi-speed, blower motor standard on all models
- No-rust base pan with integrated drain pan standard on all units
- Durable pre-painted steel cabinet
- Louvered coil enclosure for protection against vandalism and hail damage
- Aerodynamic fan blade design reduces the overall sound
- All models available with optional factory installed tin-coated copper evaporator coil.
(These models are identified with letters TP in the 11th and 12th positions in the model numbers)

LIMITED WARRANTY*

- 10 year parts limited warranty (including compressor and coils)
- * 5 years parts limited warranty if not registered within 90 days of original installation. See warranty certificate for complete details and restrictions.



Use of the AHRI Certified TM Mark indicates a manufacturer's participation in the program. For verification of certification for individual products, go to www.ahridirectory.org.



As an Energy Star® Partner, International Comfort Products has determined that this product meets the ENERGY STAR® guidelines for energy efficiency.



UNIT PERFORMANCE DATA						
Model Number	Nominal Tons	COOLING			Unit Dimensions Height x Width x Depth inches (mm)	Operating Weight lbs (kg)
		Net Capacity BTU/h @ 95°F(35°C)	SEER	EER		
PAJ424000K000A	2	22,400	14	11.5	30-1/8 x 51 x 32 (765 x 1295 x 813)	230 (104)
PAJ424000KTP0A						
PAJ430000K000A	2.5	28,600	14	11.5		249 (113)
PAJ430000KTP0A						
PAJ436000K000A	3	35,000	14	11.5		272 (123)
PAJ436000KTP0A						
PAJ442000K000A	3.5	41,000	14.5	11.5	34-1/8 x 51 x 32 (867 x 1295 x 813)	275 (125)
PAJ442000KTP0A						
PAJ448000K000A	4	47,000	14	11.5	42-1/8 x 51 x 32 (1070 x 1295 x 813)	318 (144)
PAJ448000KTP0A						
PAJ460000K000A	5	54,000	14	11.3		344 (156)
PAJ460000KTP0A						

MODEL NOMENCLATURE										
MODEL SERIES	1	2, 3	4	5,6	7,8,9	10	11,12	13	14	15
	P	AJ	4	36	000	K	00	0	A	1
P = Package										
AJ = Air Conditioner										
4 = 14 SEER										
24 = 2 Tons										
30 = 2.5 Tons										
36 = 3 Tons										
42 = 3.5 Tons										
48 = 4 Tons										
60 = 5 Tons										
NOMINAL COOLING CAPACITY										
000 = no factory heat NOMINAL HEATING BTUH (input)										
K = 208/230-1-60 VOLTAGE										
00 = No options										
TP – Tin Plated Copper Evaporator Main Tubes FACTORY INSTALLED OPTIONS										
0 = Standard FEATURE CODE										
Sales Model Digit										
Engineering Digit										

AHRI* CAPACITY RATINGS

Cooling Capacities and Efficiencies

UNIT SIZE	NOMINAL TONS	STANDARD CFM	NET COOLING CAPACITY AT 95°F (35°C) (Btuh)	EER†	SEER**
24	2	800	22400	11.5	14
30	2.5	1000	28600	11.5	14
36	3	1200	35000	11.5	14
42	3.5	1400	41000	11.5	14.5
48	4	1600	47000	11.5	14
60	5	1850	54000	11.3	14

LEGEND

dB---Sound Levels (decibels)

db—Dry Bulb

SEER—Seasonal Energy Efficiency Ratio

wb—Wet Bulb

COP---Coefficient of Performance

* Air Conditioning Heating & Refrigeration Institute

† At "A" conditions—80°F (26.7°C) indoor db/67°F (19.4°C) indoor wb & 95°F (35°C) outdoor db.

** Rated in accordance with U.S. Government DOE Department of Energy) test procedures and/or AHRI Standards 210/240---08, 270-1995.

Notes:

1. Ratings are net values, reflecting the effects of circulating fan heat.

Ratings are based on:

Cooling Standard: 80°F (26.7°C) db, 67°F wb (19.4°C) indoor entering---air temperature and 95°F db (35°C) outdoor entering---air temperature.

2. Before purchasing this appliance, read important energy cost and efficiency information available from your retailer.

A-Weighted Sound Power Level (dBA)

UNIT SIZE	STANDARD RATING (dBA)	TYPICAL OCTAVE BAND SPECTRUM (dBA without tone adjustment)							
		125	250	500	1000	2000	4000	8000	
24	72	54.4	54.9	58.8	67.5	53.7	48.5	39.4	
30	75	55.4	63.9	62.8	59.0	54.7	45.5	37.9	
36	75	60.4	58.9	62.8	63.0	58.7	52.5	45.4	
42	75	59.9	64.4	69.3	68.0	65.2	63.0	60.4	
48	76	58.4	61.9	65.3	65.5	59.7	55.0	47.4	
60	80	72.9	65.4	68.8	70.5	65.2	60.5	50.9	

PHYSICAL DATA

UNIT SIZE	24	30	36	42	48	60
NOMINAL CAPACITY (ton)	2	2.5	3	3.5	4	5
SHIPPING WEIGHT (lb)	286	298	329	352	368	402
(kg)	130	136	150	160	167	183
COMPRESSOR TYPE	RECIPROCATING			SCROLL		
REFRIGERANT	R-410A					
REFRIGERANT QUANTITY (lb)	3.3	5.2	5.5	7.3	6.3	7.5
QUANTITY (kg)	1.5	2.4	2.5	3.3	2.9	3.4
METERING DEVICE ID	Piston					TXV
ORIFICE OD (in.)	0.057	0.063	0.067	0.076	0.080	N/A
(mm)	1.45	1.60	1.70	1.93	2.03	
OUTDOOR COIL ROWS...FINS/in.	1...20	1...20	2...20	2...20	2...20	2...20
FACE AREA (sq. ft)	9.1	9.1	9.1	10.2	13.0	15.5
OUTDOOR FAN NOMINAL AIRFLOW (CFM)	2400	2400	2700	2700	2700	3000
DIAMETER (in.)	20	20	20	20	20	20
DIAMETER (mm)	508	508	508	508	508	508
MOTOR HP (RPM)	1/8 (825)	1/8 (825)	1/4 (1100)	1/4 (1100)	1/4 (1100)	1/3 (1110)
INDOOR COIL ROWS...FINS/in.	2...12	3...12	3...12	3...12	3...15	3...15
FACE AREA (sq. ft)	4.3	4.3	4.3	4.9	4.9	6.1
INDOOR BLOWER NOMINAL COOLING AIRFLOW (CFM)	800	1000	1200	1400	1600	1850
NOMINAL SIZE W x D (in.)	8 x 11	8 x 11	9 x 12	9 x 12	11 x 12	11 x 12
(mm)	254 x 203	254 x 203	279 x 229	279 x 229	279 x 229	267 x 305
MOTOR (HP)	1/3	1/3	1/2	1/2	3/4	1
HIGH-PRESSURE SWITCH (psig) CUTOUT RESET (AUTO)	650 +/- 15 420 +/- 25					
RETURN-AIR FILTERS THROWAWAY (in.) (mm)	20x20x1 508x508x25	20x24x1 508x610x25	24x30x1 610x762x25		24x36x1 610x914x25	

*Required filter sizes shown are based on the AHRI (Air Conditioning, Heating and Refrigeration Institute) rated airflow at a velocity of 300 ft/min for throwaway type or 450 ft/min for high capacity type. Recommended filters are 1-in. (25.4 mm) thick.

Multiplication Factors

HEATER kW RATING	VOLTAGE DISTRIBUTION	MULTIPLICATION FACTOR
240	200	.69
	208	.75
	230	.92
	240	1.00

Example: 15.0 kW (at 240v) heater on 208v
 = 15.0 (.75 mult factor)
 = 11.25 capacity at 208v

DIMENSIONAL DRAWINGS — 24-36

UNIT	ELECTRICAL CHARACTERISTICS	UNIT WT.		UNIT HEIGHT		CENTER OF GRAVITY IN [MM]		
		LEBS.	KG.	A	X	Y	Z	
PAJ424000K**OB	208/230-1-60	230	104	30-1/8 [765]	14 [356]	19 [483]	14 [356]	14 [356]
PAJ430000K**OB	208/230-1-60	249	113	30-1/8 [765]	14 [356]	19 [483]	14 [356]	14 [356]
PAJ436000K**OB	208/230-1-60	272	123	30-1/8 [765]	14 [356]	19 [483]	14 [356]	14 [356]

REQUIRED CLEARANCES TO COMBUSTIBLE MATL.

TOP OF UNIT.....	INCHES [MM]
BOTTOM OF UNIT.....	0
SIDE OF UNIT WITH DUCT OPENINGS.....	0
SIDE OF UNIT OPPOSITE DUCT OPENINGS.....	0

NEC. REQUIRED CLEARANCES.

BETWEEN UNITS, POWER ENTRY SIDE.....	INCHES [MM]
UNIT AND UNGROUNDED SURFACES, POWER ENTRY SIDE.....	42.0 [1067]
UNIT AND BLOCK OR CONCRETE WALLS AND OTHER GROUNDED SURFACES, POWER ENTRY SIDE.....	36.0 [914]

REQUIRED CLEARANCE FOR SERVICING

TOP OF UNIT.....	INCHES [MM]
SIDE OF UNIT OPPOSITE DUCT OPENINGS.....	36.0 [914]
SIDE OF UNIT WITH POWER ENTRY (EXCEPT FOR NEC REQUIREMENTS).....	30.0 [762]

NOTE: CLEARANCES MUST BE MAINTAINED TO PREVENT RECIRCULATION OF AIR FROM OUTDOOR FAN DISCHARGE. A REMOVABLE FENCE OR BARRICADE REQUIRES NO CLEARANCE.

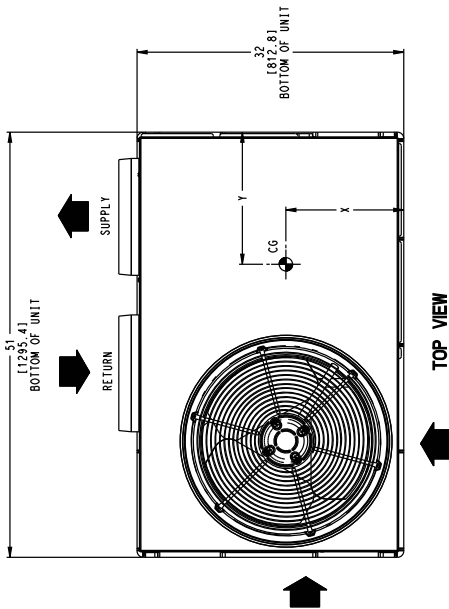

TOP VIEW

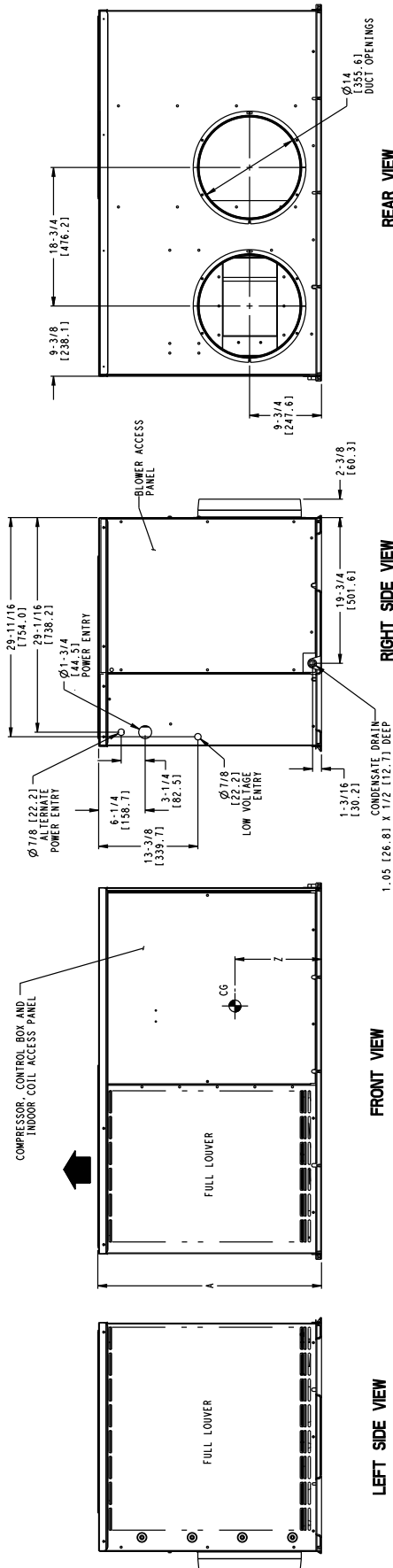

FRONT VIEW

LEFT SIDE VIEW

RIGHT SIDE VIEW

REAR VIEW

DIMENSIONS IN [] ARE IN MM

REV	50CV502809
	-

DIMENSIONAL DRAWINGS — 42-60

UNIT	ELECTRICAL CHARACTERISTICS	UNIT WT.			UNIT HEIGHT			CENTER OF GRAVITY IN [MM]		
		LBS.	KG.	A	X	Y	Z			
PAJ442000K**OB	208/230-1-60	275	125	34-1/8 [867]	14 [356]	19 [483]	16 [406]			
PAJ448000K**OB	208/230-1-60	318	144	42-1/8 [1070]	14 [356]	19 [483]	19-3/4 [503]			
PAJ460000K**OB	208/230-1-60	344	156	42-1/8 [1070]	14 [356]	19 [483]	19-3/4 [503]			

REQUIRED CLEARANCES TO COMBUSTIBLE MATL.

	INCHES [MM]
TOP OF UNIT.....	0
BOTTOM OF UNIT.....	0
SIDE OF UNIT WITH DUCT OPENINGS.....	0
SIDE OF UNIT OPPOSITE DUCT OPENINGS.....	0

NEC. REQUIRED CLEARANCES.

	INCHES [MM]
BETWEEN UNITS, POWER ENTRY SIDE.....	42.0 [1067]
UNIT AND UNGROUNDED SURFACES, POWER ENTRY SIDE.....	36.0 [914]
UNIT AND BLOCK OR CONCRETE WALLS AND OTHER GROUNDED SURFACES, POWER ENTRY SIDE.....	42.0 [1067]

REQUIRED CLEARANCE FOR SERVICING

	INCHES [MM]
TOP OF UNIT.....	36.0 [914]
SIDE OF UNIT OPPOSITE DUCT OPENINGS.....	36.0 [914]
SIDE OF UNIT WITH POWER ENTRY.....	30.0 [762]
(EXCEPT FOR NEC REQUIREMENTS)	30.0 [762]

NOTE: CLEARANCES MUST BE MAINTAINED TO PREVENT RECIRCULATION OF AIR FROM OUTDOOR FAN DISCHARGE. A REMOVABLE FENCE OR BARRICADE REQUIRES NO CLEARANCE.

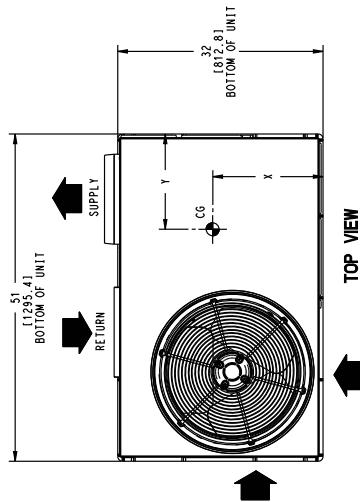

DIMENSIONS IN [] ARE IN MM

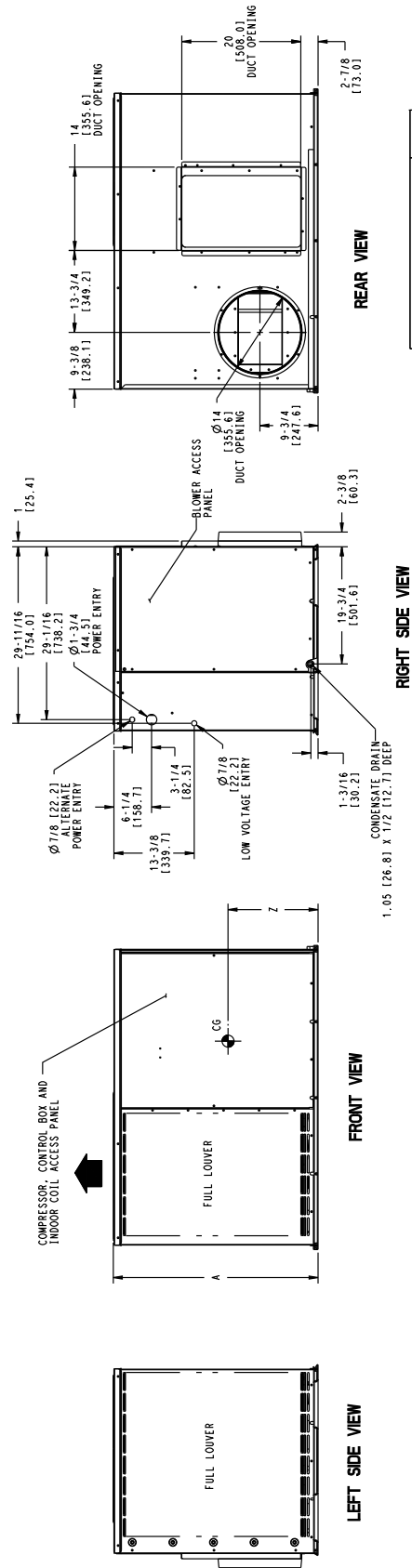

REV	50CY502810
	-

SELECTION PROCEDURE

A. DETERMINE COOLING AND HEATING REQUIREMENTS AT DESIGN CONDITIONS.

Given:

Required Cooling Capacity (TC) 34,000 Btuh
Sensible Heat Capacity (SHC) 25,000 Btuh
Required Heating Capacity 15,000 Btuh
Outdoor Entering–Air Temperature 95° F (35° C)
Indoor Entering–Air Temperature 80° F edb (26.7° C);
67° F (19.4° C) ewb
Indoor–Air Quantity 1200 CFM
External Static Pressure 0.20 IN. W.C.
Electrical Characteristics (V–Ph–Hz) 230–1–60

B. SELECT UNIT BASED ON REQUIRED COOLING CAPACITY (3–TON EXAMPLE)

Enter Cooling Capacities table at condenser entering temperature of 95° F (35° C), indoor air entering at 1200 CFM and 67° F (19.4° C) ewb. The 36 unit provides a total cooling capacity of 34,500 Btuh and a sensible heat capacity of 26,040 Btuh.

For indoor–air temperature other than 80° F (26.7° C) edb, calculate sensible heat capacity correction, as required, using the formula found following the Cooling Capacities tables.

NOTE: Unit ratings are net capacities.

C. SELECT ELECTRIC HEAT.

The required heating capacity is 15,000 Btuh (given).
Determine the electric heat capacity in kW.

$$\frac{15,000 \text{ Btuh}}{3414 \text{ Btuh/kW}} = 3.8 \text{ kW of heat required}$$

Enter the Accessory Electric Heater table on page 4 for 208/230, single–phase, 036 unit. The 5–kW heater at 240v most closely satisfies the heating required. To calculate kW at 230 V, multiply the heater kW by multiplication factor 0.92 found in the Multiplication Factors table on page 4.

$$5 \text{ kW} \times 0.92 = 4.6 \text{ kW}$$

$$4.6 \text{ kW} \times 3414 \text{ Btuh/kW} = 15,704 \text{ Btuh}$$

D. DETERMINE FAN SPEED AND POWER REQUIREMENTS AT DESIGN CONDITIONS.

Before entering the air delivery tables, calculate the total static pressure required. From the given, Filter Pressure Drop table, and the Accessory Electric Heat Pressure Drop table find:

External static pressure 0.20 IN. W.C.
Filter 0.10 IN. W.C.
Electric Heat 0.04 IN. W.C.
Total static pressure 0.34 IN. W.C.

Enter the table for Dry Coil Air Delivery — Horizontal Discharge. At 0.4 IN. W.C. external static pressure and medium speed, the motor delivers 1236 CFM.

PERFORMANCE DATA

Cooling Capacities

24

EVAPORATOR AIR		CONDENSER ENTERING AIR TEMPERATURES °F (°C)														
		75 (24)			85 (29)			95 (35)			105 (41)			115 (46)		
		CFM	EWB °F (°C)	Capacity MBtuh		Total Sys KW	Capacity MBtuh		Total Sys KW	Capacity MBtuh		Total Sys KW	Capacity MBtuh		Total Sys KW	
Total	Sens			Total	Sens		Total	Sens		Total	Sens					
700	57 (14)	23.14	23.14	21.24	1.74	19.25	19.24	1.86	17.04	17.04	1.96	14.82	14.82	2.07		
	62 (17)	24.27	20.27	19.60	1.75	19.62	18.81	1.87	17.08	17.08	1.96	14.84	14.84	2.07		
	63 (17)	24.78	16.65	15.97	1.76	20.01	15.23	1.89	17.24	14.26	1.96	14.37	13.22	2.05		
	67 (19)	26.88	17.28	16.63	1.79	21.93	15.96	1.93	19.35	15.21	2.06	16.25	14.17	2.13		
	71 (22)	28.93	14.81	14.21	1.81	23.86	13.55	1.96	21.29	12.86	2.10	18.38	12.02	2.23		
800	57 (14)	24.22	24.22	22.22	1.77	20.22	20.22	1.91	17.96	17.96	2.01	15.58	15.58	2.12		
	62 (17)	24.93	21.65	20.97	1.77	20.25	20.22	1.91	18.01	18.01	2.02	15.61	15.61	2.12		
	63 (17)	25.39	17.60	16.93	1.78	20.50	16.21	1.91	17.69	15.26	2.00	14.75	14.19	2.08		
	67 (19)	27.49	18.23	17.62	1.80	22.40	16.95	1.95	19.79	16.23	2.08	16.66	15.24	2.16		
	71 (22)	29.52	15.44	14.86	1.83	24.33	14.21	1.98	21.69	13.53	2.13	18.83	12.79	2.26		
900	57 (14)	25.14	25.14	23.05	1.79	20.97	20.97	1.93	18.76	18.76	2.06	16.25	16.25	2.16		
	62 (17)	25.51	22.89	22.17	1.79	20.99	20.99	1.93	18.80	18.80	2.07	16.27	16.27	2.16		
	63 (17)	25.88	18.45	17.81	1.80	20.87	17.11	1.93	18.08	16.21	2.03	15.08	15.10	2.11		
	67 (19)	27.96	19.09	18.51	1.82	22.76	17.88	1.97	20.11	17.19	2.10	17.01	16.23	2.19		
	71 (22)	29.97	16.02	15.45	1.85	24.70	14.82	2.00	21.98	14.14	2.15	19.16	13.46	2.28		

See Legend and Notes on page 9.

30

EVAPORATOR AIR		CONDENSER ENTERING AIR TEMPERATURES °F (°C)														
		75 (24)			85 (29)			95 (35)			105 (41)			115 (46)		
		CFM	EWB °F (°C)	Capacity MBtuh		Total Sys KW	Capacity MBtuh		Total Sys KW	Capacity MBtuh		Total Sys KW	Capacity MBtuh		Total Sys KW	
Total	Sens			Total	Sens		Total	Sens		Total	Sens					
875	57 (14)	29.36	29.36	27.29	2.18	25.09	25.09	2.38	22.44	22.44	2.55	19.75	19.75	2.74		
	62 (17)	30.31	26.51	25.23	2.19	25.20	24.98	2.39	22.49	22.49	2.55	19.80	19.80	2.74		
	63 (17)	30.88	21.56	20.35	2.20	25.55	19.11	2.40	22.14	17.60	2.54	18.72	16.09	2.69		
	67 (19)	33.55	22.45	21.29	2.23	28.03	20.09	2.45	24.81	18.76	2.65	21.11	17.24	2.80		
	71 (22)	36.25	19.13	18.02	2.27	30.56	16.92	2.50	27.57	15.80	2.73	23.82	14.43	2.92		
1000	57 (14)	30.74	30.74	28.55	2.22	26.32	26.32	2.44	23.64	23.64	2.63	20.76	20.76	2.81		
	62 (17)	31.21	28.48	26.89	2.23	26.36	26.36	2.44	23.68	23.68	2.63	20.80	20.80	2.81		
	63 (17)	31.61	22.92	21.71	2.23	26.15	20.48	2.44	22.71	18.94	2.58	19.19	17.36	2.74		
	67 (19)	34.29	23.85	22.70	2.27	28.60	21.50	2.49	25.44	20.23	2.70	21.63	18.64	2.85		
	71 (22)	36.94	20.07	18.99	2.30	31.12	17.87	2.53	28.07	16.75	2.76	24.30	15.42	2.97		
1125	57 (14)	31.88	31.88	29.60	2.26	27.29	27.29	2.48	24.63	24.63	2.70	21.60	21.60	2.88		
	62 (17)	31.96	31.67	29.63	2.26	27.33	27.33	2.49	24.67	24.67	2.70	21.64	21.64	2.88		
	63 (17)	32.18	24.17	23.00	2.26	26.61	21.75	2.47	23.18	20.21	2.63	19.65	18.50	2.79		
	67 (19)	34.84	25.17	24.02	2.30	29.03	22.83	2.52	25.96	21.57	2.74	22.07	19.95	2.90		
	71 (22)	37.48	20.94	19.87	2.33	31.50	18.78	2.56	28.44	17.64	2.80	24.69	16.39	3.02		

See Legend and Notes on page 9.

COOLING CAPACITIES (CONT)

36

EVAPORATOR AIR		CONDENSER ENTERING AIR TEMPERATURES ° F (°C)																	
		75 (24)			85 (29)			95 (35)			105 (41)			115 (46)					
		Capacity MBtuh		Total Sys KW	Capacity MBtuh		Total Sys KW	Capacity MBtuh		Total Sys KW	Capacity MBtuh		Total Sys KW	Capacity MBtuh		Total Sys KW			
CFM	EWB ° F (°C)	Total	Sens	Total	Sens	Total	Sens	Total	Sens	Total	Sens	Total	Sens	Total	Sens	Total	Sens		
		1050	57 (14)	34.95	34.95	2.39	32.78	32.78	2.65	30.54	30.54	2.91	28.13	28.13	3.18	25.17	25.17	3.42	
62 (17)	36.15		32.02	2.40	31.07	31.07	2.66	30.78	29.99	2.92	28.17	28.17	3.18	25.21	25.21	3.42			
63 (17)	36.83		26.05	2.40	34.09	25.10	2.67	31.22	24.06	2.93	28.11	22.91	3.17	24.25	21.41	3.37			
67 (19)	39.89		27.04	2.42	37.06	26.18	2.70	34.15	25.24	2.99	31.05	24.22	3.28	27.26	22.90	3.51			
71 (22)	43.61		21.93	2.45	40.81	21.13	2.74	37.84	20.24	3.04	34.70	19.28	3.34	31.35	18.25	3.66			
1200	57 (14)	36.52	36.52	2.43	34.27	34.27	2.70	31.94	31.94	2.99	29.43	29.43	3.26	26.39	26.39	3.51			
	62 (17)	37.10	34.24	2.43	34.48	33.26	2.70	31.97	31.97	2.99	29.47	29.47	3.27	26.44	26.44	3.51			
	63 (17)	37.64	27.56	2.44	34.83	26.64	2.71	31.89	25.65	2.98	28.72	24.50	3.23	24.81	22.99	3.43			
	67 (19)	40.69	28.57	2.46	37.82	27.76	2.74	34.80	26.85	3.03	31.65	25.87	3.32	27.90	24.63	3.58			
	71 (22)	44.31	22.79	2.48	41.49	22.03	2.77	38.44	21.17	3.07	35.23	20.23	3.39	31.83	19.23	3.70			
1350	57 (14)	37.79	37.79	2.47	35.48	35.48	2.74	33.04	33.04	3.03	30.50	30.50	3.33	27.45	27.45	3.59			
	62 (17)	37.98	36.24	2.47	35.53	35.53	2.74	33.08	33.08	3.03	30.54	30.54	3.33	27.50	27.50	3.60			
	63 (17)	38.27	28.95	2.47	35.39	28.07	2.74	32.40	27.11	3.02	29.23	26.00	3.29	25.31	24.46	3.49			
	67 (19)	41.27	29.95	2.49	38.36	29.20	2.77	35.29	28.34	3.06	32.11	27.40	3.36	28.45	26.26	3.64			
	71 (22)	44.83	23.55	2.51	41.97	22.83	2.80	38.88	22.01	3.11	35.62	21.09	3.42	32.18	20.13	3.74			

See Legend and Notes on page 9.

42

EVAPORATOR AIR		CONDENSER ENTERING AIR TEMPERATURES ° F (°C)																	
		75 (24)			85 (29)			95 (35)			105 (41)			115 (46)					
		Capacity MBtuh		Total Sys KW	Capacity MBtuh		Total Sys KW	Capacity MBtuh		Total Sys KW	Capacity MBtuh		Total Sys KW	Capacity MBtuh		Total Sys KW			
CFM	EWB ° F (°C)	Total	Sens	Total	Sens	Total	Sens	Total	Sens	Total	Sens	Total	Sens	Total	Sens	Total	Sens		
		1225	57 (14)	41.68	41.68	2.75	38.94	38.94	3.11	35.98	35.98	3.49	32.25	32.25	3.87	28.66	28.66	4.32	
62 (17)	42.95		38.93	2.75	39.78	36.79	3.12	36.43	34.57	3.50	32.28	32.28	3.87	28.71	28.71	4.32			
63 (17)	43.70		31.61	2.75	40.44	29.72	3.12	36.99	27.79	3.51	32.43	25.38	3.87	27.98	23.06	4.30			
67 (19)	47.16		32.78	2.77	43.74	30.91	3.13	40.27	29.04	3.52	36.10	26.97	3.96	31.37	24.61	4.39			
71 (22)	51.59		26.51	2.78	47.98	24.89	3.15	44.33	23.26	3.55	40.57	21.60	3.99	36.10	19.78	4.49			
1400	57 (14)	43.43	43.43	2.79	40.56	40.56	3.15	37.56	37.56	3.55	33.84	33.84	3.94	30.06	30.06	4.39			
	62 (17)	44.02	41.66	2.79	40.84	39.39	3.16	37.60	37.60	3.55	33.90	33.90	3.94	30.11	30.11	4.40			
	63 (17)	44.60	33.50	2.79	41.26	31.57	3.16	37.77	29.61	3.55	33.24	27.21	3.92	28.66	24.78	4.36			
	67 (19)	48.06	34.74	2.81	44.57	32.83	3.17	41.00	30.90	3.56	37.08	28.93	4.01	32.09	26.48	4.45			
	71 (22)	52.46	27.65	2.82	48.78	26.00	3.19	45.03	24.35	3.59	41.21	22.67	4.02	36.86	20.91	4.53			
1575	57 (14)	44.86	44.86	2.82	41.89	41.89	3.19	38.82	38.82	3.59	35.20	35.20	4.03	31.25	31.25	4.47			
	62 (17)	45.00	44.04	2.83	41.94	41.94	3.20	38.88	38.88	3.59	35.25	35.25	4.02	31.28	31.28	4.47			
	63 (17)	45.28	35.25	2.83	41.88	33.29	3.20	38.36	31.31	3.59	33.90	28.93	3.98	29.21	26.39	4.41			
	67 (19)	48.74	36.57	2.84	45.17	34.62	3.21	41.56	32.62	3.60	37.71	30.65	4.05	32.66	28.22	4.50			
	71 (22)	53.13	28.71	2.86	49.38	27.04	3.23	45.55	25.35	3.63	41.66	23.65	4.07	37.49	21.93	4.58			

See Legend and Notes on page 9.

COOLING CAPACITIES (CONT)

48

EVAPORATOR AIR		CONDENSER ENTERING AIR TEMPERATURES °F (°C)																			
		75 (24)				85 (29)				95 (35)				105 (41)				115 (46)			
		CFM	EWB °F (°C)	Capacity MBtuh		Total Sys KW	Capacity MBtuh		Total Sys KW	Capacity MBtuh		Total Sys KW	Capacity MBtuh		Total Sys KW	Capacity MBtuh		Total Sys KW			
Total	Sens			Total	Sens		Total	Sens		Total	Sens		Total	Sens							
1400	57 (14)	46.69	46.69	3.18	43.96	43.96	3.55	41.20	41.20	3.97	38.15	38.15	4.45	34.26	34.26	4.96					
	62 (17)	48.24	40.86	3.19	45.07	40.07	3.56	41.86	39.18	3.99	38.39	38.02	4.46	34.32	34.32	4.97					
	63 (17)	49.13	33.18	3.19	45.86	32.38	3.57	42.55	31.50	4.00	38.89	30.43	4.47	34.04	28.78	4.95					
	67 (19)	53.03	34.45	3.21	49.63	33.69	3.59	46.16	32.87	4.03	42.51	31.94	4.54	38.08	30.67	5.10					
	71 (22)	58.07	27.87	3.25	54.53	27.15	3.63	50.89	26.37	4.07	47.09	25.48	4.58	43.08	24.48	5.17					
1600	57 (14)	48.69	48.69	3.24	45.86	45.86	3.62	42.97	42.97	4.06	39.87	39.87	4.56	35.98	35.98	5.08					
	62 (17)	49.45	43.78	3.24	46.24	42.96	3.62	43.08	42.83	4.06	39.93	39.93	4.56	36.04	36.04	5.08					
	63 (17)	50.14	35.19	3.25	46.79	34.40	3.62	43.38	33.54	4.06	39.71	32.52	4.55	34.85	30.91	5.04					
	67 (19)	54.04	36.51	3.27	50.57	35.78	3.65	47.00	35.00	4.09	43.31	34.10	4.60	39.07	33.00	5.18					
	71 (22)	59.08	29.08	3.31	55.45	28.38	3.69	51.71	27.61	4.13	47.83	26.75	4.64	43.74	25.74	5.24					
1800	57 (14)	50.32	50.32	3.30	47.39	47.39	3.68	44.38	44.38	4.12	41.24	41.24	4.63	37.45	37.45	5.19					
	62 (17)	50.52	46.35	3.30	47.46	47.46	3.68	44.44	44.44	4.12	41.29	41.29	4.63	37.50	37.50	5.19					
	63 (17)	50.90	37.05	3.30	47.50	36.30	3.68	44.02	35.46	4.12	40.35	34.49	4.62	35.52	32.90	5.12					
	67 (19)	54.81	38.44	3.33	51.26	37.75	3.70	47.64	36.98	4.14	43.89	36.11	4.65	39.74	35.07	5.24					
	71 (22)	59.83	30.17	3.37	56.13	29.51	3.75	52.32	28.76	4.19	48.35	27.90	4.70	44.21	26.91	5.30					

See Legend and Notes on page 9.

60

EVAPORATOR AIR		CONDENSER ENTERING AIR TEMPERATURES °F (°C)																			
		75 (24)				85 (29)				95 (35)				105 (41)				115 (46)			
		CFM	EWB °F (°C)	Capacity MBtuh		Total Sys KW	Capacity MBtuh		Total Sys KW	Capacity MBtuh		Total Sys KW	Capacity MBtuh		Total Sys KW	Capacity MBtuh		Total Sys KW			
Total	Sens			Total	Sens		Total	Sens		Total	Sens		Total	Sens							
1500	57 (14)	52.95	52.95	3.74	50.23	50.23	4.14	47.43	47.43	4.61	44.47	44.47	5.15	41.30	41.30	5.78					
	62 (17)	55.05	45.97	3.75	51.84	44.39	4.16	48.53	42.78	4.62	45.08	41.06	5.16	41.48	39.18	5.78					
	63 (17)	56.01	37.50	3.76	52.73	36.05	4.17	49.33	34.54	4.63	45.76	32.97	5.17	42.01	31.33	5.79					
	67 (19)	59.99	38.77	3.80	56.43	37.29	4.20	52.75	35.77	4.67	48.90	34.18	5.21	44.88	32.53	5.83					
	71 (22)	65.50	31.45	3.84	61.58	30.06	4.25	57.53	28.62	4.72	53.33	27.13	5.26	48.93	25.58	5.89					
1700	57 (14)	54.98	54.98	3.81	52.11	52.11	4.21	49.12	49.12	4.68	45.98	45.98	5.23	42.63	42.63	5.85					
	62 (17)	56.20	49.14	3.82	52.89	47.48	4.22	49.49	45.72	4.69	46.04	46.04	5.23	42.69	42.69	5.86					
	63 (17)	57.05	39.66	3.83	53.64	38.16	4.23	50.11	36.61	4.70	46.43	34.99	5.23	42.56	33.29	5.85					
	67 (19)	61.05	41.09	3.86	57.35	39.56	4.26	53.53	37.99	4.73	49.57	36.36	5.27	45.42	34.64	5.89					
	71 (22)	66.61	32.86	3.91	62.53	31.43	4.31	58.37	29.96	4.78	54.02	28.44	5.33	49.49	26.85	5.95					
1850	57 (14)	56.30	56.30	3.86	53.30	53.30	4.27	50.20	50.20	4.74	46.93	46.93	5.28	43.46	43.46	5.91					
	62 (17)	56.95	51.37	3.87	53.60	49.58	4.27	50.27	50.27	4.74	46.99	46.99	5.28	43.52	43.52	5.91					
	63 (17)	57.68	41.23	3.87	54.17	39.68	4.27	50.58	38.10	4.74	46.82	36.45	5.28	42.89	34.72	5.90					
	67 (19)	61.67	42.77	3.90	57.88	41.20	4.31	54.00	39.60	4.78	49.95	37.93	5.32	45.73	36.18	5.94					
	71 (22)	67.25	33.87	3.95	63.10	32.42	4.36	58.84	30.93	4.83	54.41	29.38	5.37	49.81	27.77	6.00					

See Legend and Notes on page 9.

* At 75° F entering dry bulb – Tennessee Valley Authority (TVA) rating conditions; all others at 80° F dry bulb.

LEGEND

BF — Bypass Factor

Ewb — Entering Wet–Bulb

kW — Total Unit Power Input

SHC — Sensible Heat Capacity (1000 Btuh)

TC — Total Capacity (1000 Btuh) (net)

NOTES:

1. Direct interpolation is permissible. Do not extrapolate.
2. The following formulas may be used:

$$t_{db} = t_{edb} - \frac{\text{Sensible capacity (Btuh)}}{1.10 \times \text{cfm}}$$

$$t_{lwb} = \text{Wet–bulb temperature corresponding to enthalpy air leaving evaporator coil (} h_{lwb} \text{)}$$

$$h_{lwb} = h_{ewb} - \frac{\text{total capacity (Btuh)}}{4.5 \times \text{cfm}}$$

Where: h_{ewb} = Enthalpy of air entering evaporator coil. The SHC is based on 80° F (26.7°C) edb temperature of air entering indoor coil.
 Below 80° F (26.7°C) edb, subtract (corr factor x cfm) from SHC.
 Above 80° F (26.7°C) edb, add (corr factor x cfm) to SHC.
 Correction Factor = $1.10 \times (1 - BF) \times (edb - 80)$.

Filter Pressure Drop (IN. W.C.)

FILTER SIZE in. (mm)	CFM																	
	500	600	700	800	900	1000	1100	1200	1300	1400	1500	1600	1700	1800	1900	2000	2100	2200
20X20X1 (508X508X25)	0.05	0.07	0.08	0.10	0.12	0.13	0.14	0.15	—	—	—	—	—	—	—	—	—	—
20X24X1 (508X610X25)	—	—	—	0.08	0.09	0.10	0.11	0.13	0.14	0.15	0.16	—	—	—	—	—	—	—
24X30X1 (610X762X25)	—	—	—	0.04	0.05	0.06	0.07	0.07	0.08	0.09	0.10	—	—	—	—	—	—	—
24X36X1 (610X914X25)	—	—	—	—	—	—	—	0.06	0.07	0.07	0.08	0.09	0.09	0.10	0.11	0.12	0.13	0.14

Accessory Electric Heat Pressure Drop (IN. W.C.)

HEATER kW	CFM							
	800	1000	1200	1400	1600	1800	2000	2200
5–20	0.033	0.037	0.042	0.047	0.052	0.060	0.067	0.075

Wet Coil Delivery*— (Deduct 10% for 208–Volt Operation)

UNIT SIZE	SPEED TAP	AIR DELIVERY ²	EXTERNAL STATIC PRESSURE (in. W.C.)									
			0.1	0.2	0.3	0.4	0.5	0.6	0.7	0.8	0.9	1.0
24	1	SCFM	965	818	777	731	670	617	563	489	451	391
	2	SCFM	1003	921	890	850	809	756	700	659	597	539
	3	SCFM	1103	1068	1034	996	962	930	892	821	791	742
30	1	SCFM	1052	1018	984	943	914	879	833	795	732	678
	2	SCFM	1141	1107	1069	1036	1006	974	932	899	856	784
	3	SCFM	1246	1213	1181	1144	1108	1078	1043	1015	973	931
36	1	SCFM	1281	1225	1178	1142	1098	1053	1008	935	878	840
	2	SCFM	1359	1321	1278	1236	1201	1160	1109	1068	992	941
	3	SCFM	1476	1441	1403	1366	1323	1289	1245	1201	1159	1117
42	1	SCFM	1453	1408	1373	1337	1295	1255	1215	1177	1134	1068
	2	SCFM	1544	1507	1475	1436	1397	1359	1326	1290	1246	1201
	3	SCFM	1614	1575	1542	1509	1467	1430	1395	1358	1323	1267
48	1	SCFM	1657	1625	1590	1554	1517	1486	1448	1417	1381	1340
	2	SCFM	1707	1673	1644	1614	1586	1549	1515	1479	1449	1407
	3	SCFM	1931	1900	1870	1840	1809	1778	1749	1714	1683	1646
60	1	SCFM	1931	1881	1833	1787	1746	1698	1670	1622	1577	1514
	2	SCFM	2038	1994	1935	1894	1851	1811	1774	1738	1691	1648
	3	SCFM	2144	2113	2052	2001	1974	1928	1898	1860	1824	1773

*Air delivery values are based on operating voltage of 230v, wet coil, without filter or electric heater. Deduct filter and electric heater pressure drops to obtain static pressure available for ducting.

NOTES:

1. Do not operate the unit at a cooling airflow that is less than 350 cfm for each 12,000 Btuh of rated cooling capacity. Evaporator coil frosting may occur at airflows below this point.
2. Standard Cubic Feet per Minute.

TYPICAL CONNECTION WIRING SCHEMATIC—208/230-1-60, 24-60

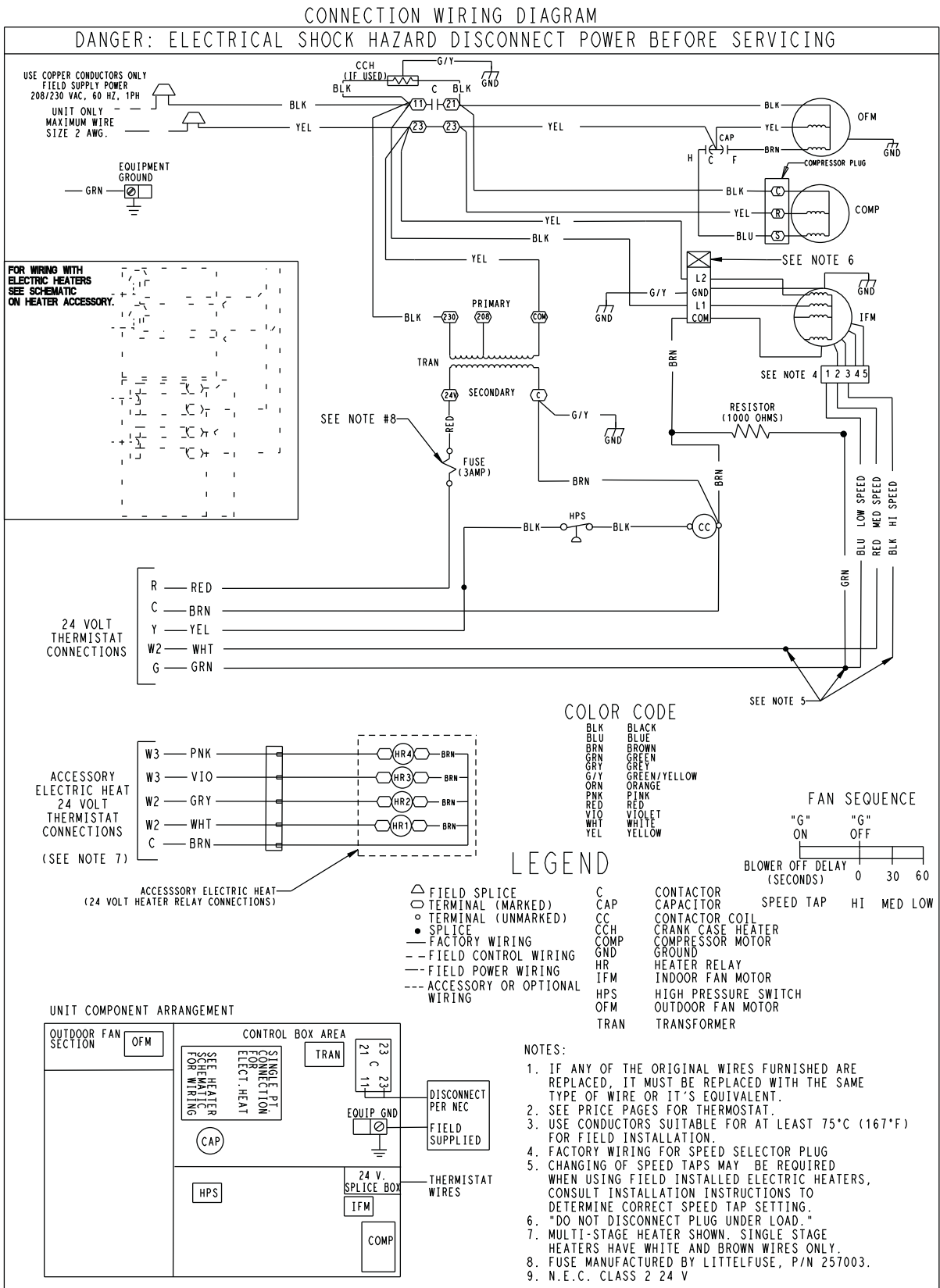

TYPICAL LADDER WIRING SCHEMATIC—208/230-1-60, 24-60

LADDER WIRING DIAGRAM

DANGER: ELECTRICAL SHOCK HAZARD DISCONNECT POWER BEFORE SERVICING

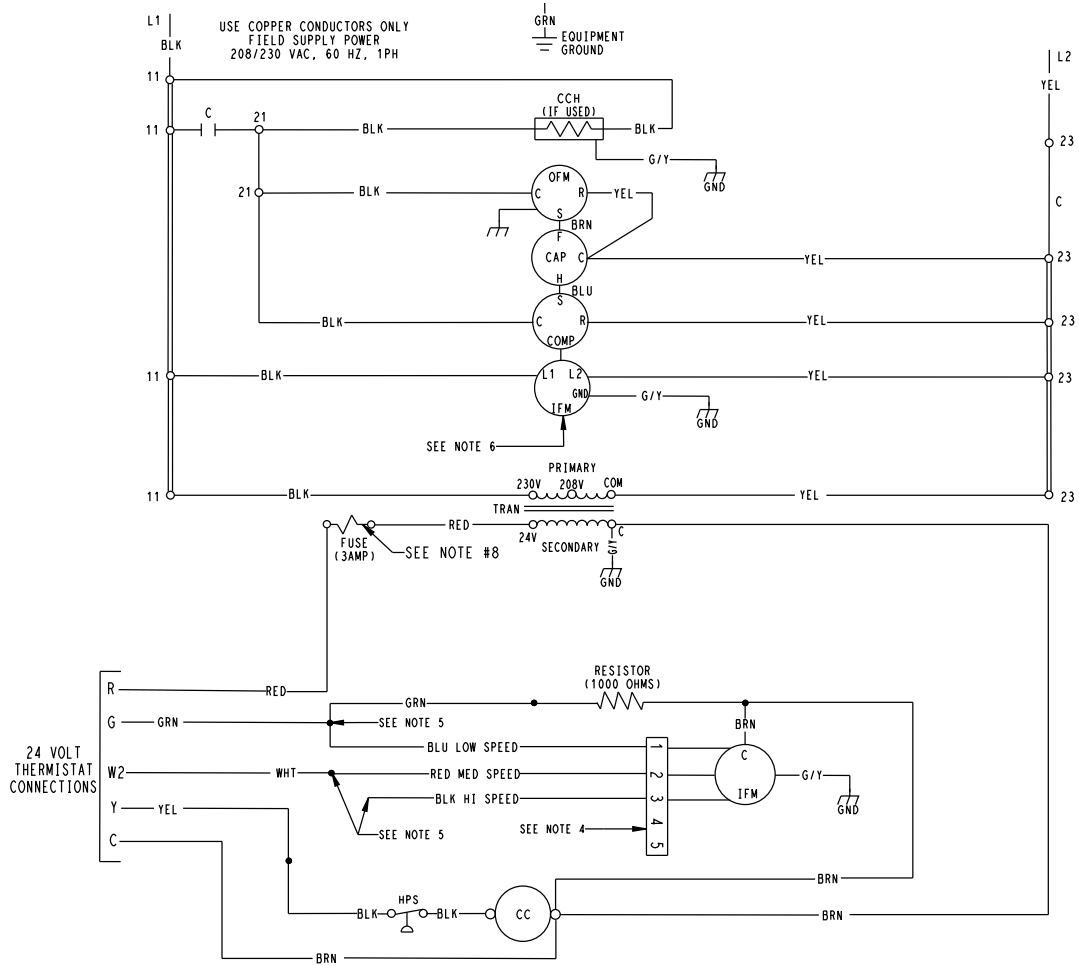

50ZP500775 B

A14549

TYPICAL FIELD WIRING

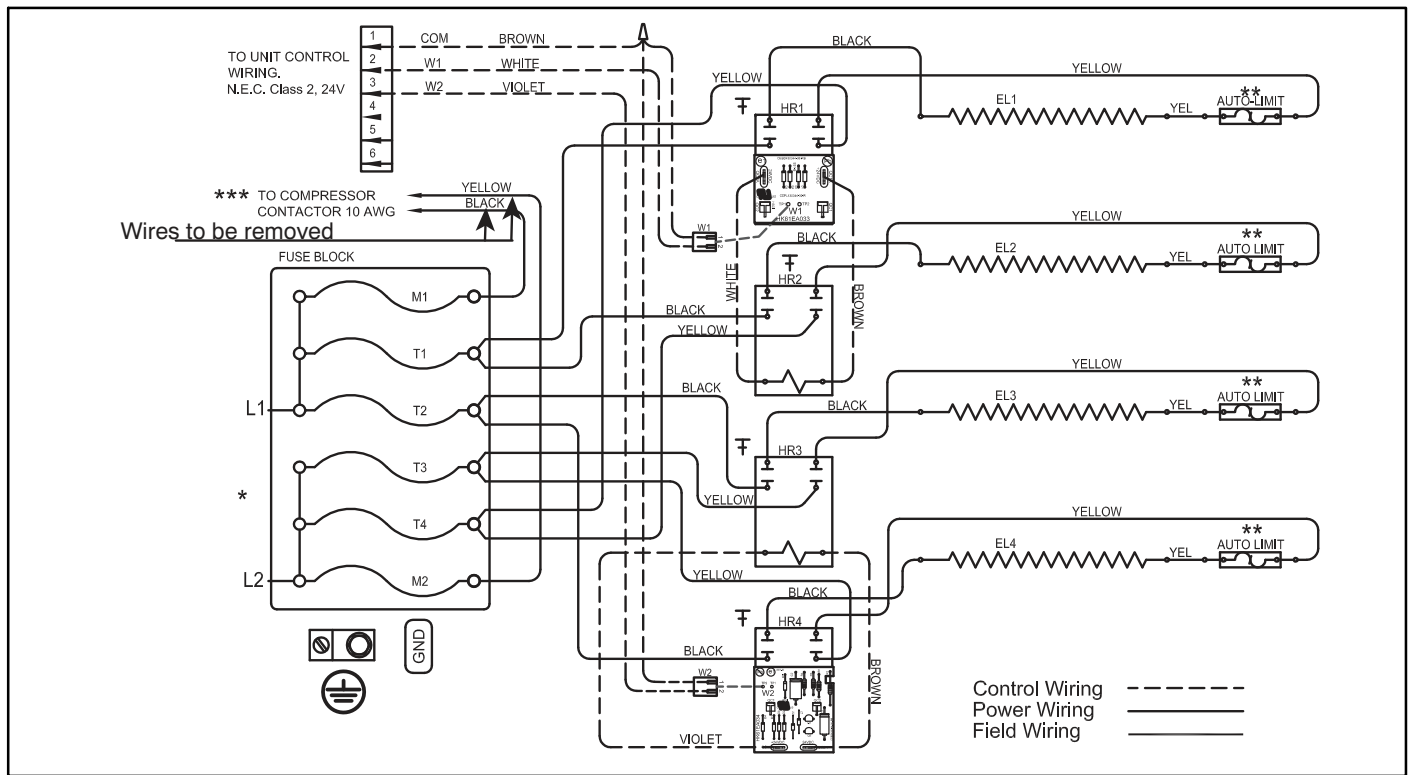

A14444

NOTE: 20 kW shown. Smaller heaters have fewer elements and controls.
Single-Phase Accessory Electric Heater Wiring

Electrical Data

Model	Nominal V-PH-HZ	Voltage Range		Compressor		OFM	IFM	Nominal kW*	Heater FLA		MCA		MOCP**
		Min	Max	RLA	LRA	FLA	FLA		208/240	208	240	208	230
24	208/230-1-60	197	253	8.7	45	0.9	2.8	-/-	-	-	14.6	14.6	20
								3.8/5	18.0	20.8	26.0	29.5	30/30
								5.6/7.5	27.0	31.3	37.3	42.6	40/45
								7.5/10	36.1	41.7	48.6	55.6	50/60
30	208/230-1-60	197	253	11.2	57	0.9	2.8	-/-	-	-	17.7	17.7	25
								3.8/5	18.0	20.8	26.0	29.5	30/30
								5.6/7.5	27.0	31.3	37.3	42.6	40/45
								7.5/10	36.1	41.7	48.6	55.6	50/60
36	208/230-1-60	197	253	14.1	78	1.7	4.1	-/-	-	-	23.4	23.4	35
								3.8/5	18.0	20.8	27.6	31.1	35/35
								5.6/7.5	27.0	31.3	38.9	44.3	40/45
								7.5/10	36.1	41.7	50.3	57.3	60/60
42	208/230-1-60	197	253	15.9	112.3	1.7	4.1	-/-	-	-	25.7	25.7	40
								3.8/5	18.0	20.8	27.6	31.1	40/40
								5.6/7.5	27.0	31.3	38.9	44.3	40/45
								7.5/10	36.1	41.7	50.3	57.3	60/60
48	208/230-1-60	197	253	19.6	130	1.7	6.0	-/-	-	-	32.2	32.2	50
								3.8/5	18.0	20.8	32.2	33.5	50/50
								5.6/7.5	27.0	31.3	41.3	46.6	50/50
								7.5/10	36.1	41.7	52.6	59.6	60/60
60	208/230-1-60	197	253	23.7	152.5	1.9	7.6	-/-	-	-	39.1	39.1	60
								3.8/5	18.0	20.8	39.1	39.1	60/60
								5.6/7.5	27.0	31.3	43.3	48.6	60/60
								7.5/10	36.1	41.7	54.6	61.6	60/70
								11.3/15	54.1	62.5	77.1	87.6	80/90
								15/20	72.1	83.3	99.6	113.6	100/125

** HACR Type Circuit breaker

LEGEND

FLA – Full Load Amps

LRA – Locked Rotor Amps

MCA – Minimum Circuit Amps

MOCP – Maximum Overcurrent Protection

RLA – Rated Load Amps

NOTES:

- In compliance with NEC (National Electrical Code) requirements for multimotor and combination load equipment (refer to NEC Articles 430 and 440), the overcurrent protective device for the unit shall be Power Supply fuse or circuit breaker.
- Minimum wire size is based on 60°C copper wire. If other than 60°C wire is used, or if length exceeds wire length in table, determine size from NEC.

*Heater capacity (kW) based on heater voltage of 208v & 240v. If power distribution voltage to unit varies from rated heater voltage, heater kW will vary accordingly.

OPERATING SEQUENCE

Cooling Operation

With a call for cooling (Y/G), the contactor is energized which brings on the compressor and outdoor fan. The indoor fan is also energized. When the cooling demand is met, Y and G are de-energized shutting off the contactor. The indoor fan stops after a 60 second delay.

Heating Operation

With a call for heating (W2), the auxiliary or electric heat energizes along with the indoor blower. In case of staged heating, W3 is energized if the demand is not met. The highest airflow selected is run while the electric heat is in operation. When heating demand is met, W3 and W2 sequentially de-energize shutting off the indoor fan and the electric heater.

Continuous Fan

With the continuous indoor fan option selected on the thermostat, G is continuously energized keeping the indoor fan running at all times.

APPLICATION DATA

Condensate trap — A 2-in. (51 mm) condensate trap must be field supplied.

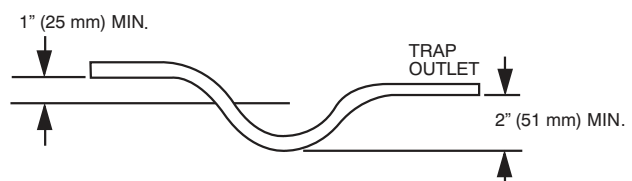

A08001

Maximum cooling airflow — To minimize the possibility of condensate blow-off from the evaporator, airflow through the units should not exceed 450 CFM/ton.

Minimum cooling airflow — The minimum cooling airflow is 350 cfm/ton.

Minimum cooling operating outdoor air temperature — All standard units have a minimum ambient operating temperature of 40°F (4.4°C). With accessory low ambient temperature kit, units can operate at temperatures down to 0°F (-17.8°C).

Maximum operating outdoor air temperature — Maximum outdoor operating air temperature for cooling is 125°F (51.7°C).

TYPICAL INSTALLATION

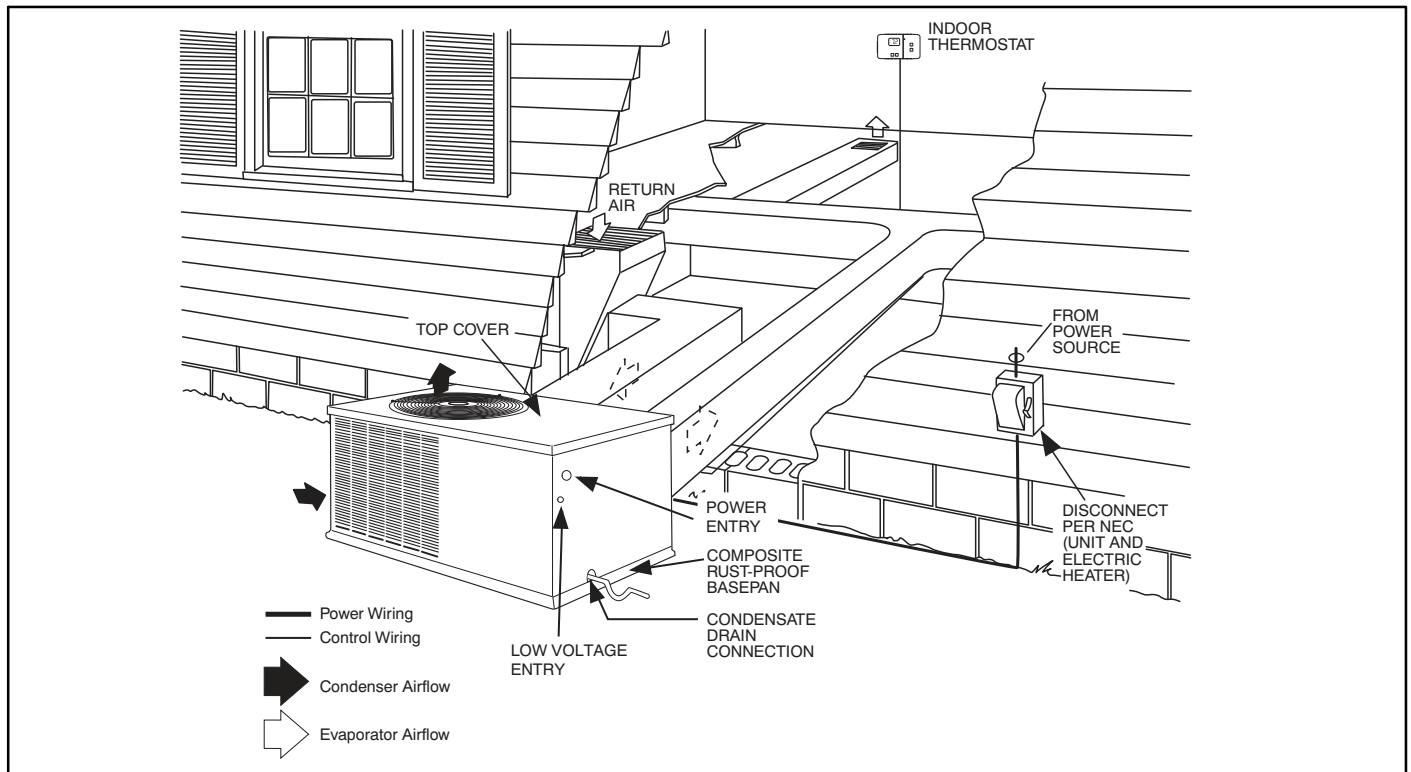

A10135

ENGINEERS' SPECIFICATION GUIDE

GENERAL

Furnish and install outdoor package, electrically controlled, air conditioner utilizing a reciprocating or scroll compressor for cooling duty. Unit shall discharge supply air horizontally as shown on contract drawings.

Nominal unit electrical characteristics shall be _____ v, _____ ph, 60 Hz. The unit shall be capable of satisfactory operation within voltage limits of _____ v to _____ v. Unit power wiring shall enter unit cabinet at a single location.

Separate power supply shall not be required for electric heat.

COOLING CAPACITY

Total cooling capacity of the unit shall be _____ Btuh or greater, and sensible capacity shall be _____ Btuh or greater at conditions of _____ cfm indoor air entering unit at _____ F dry bulb, _____ F wet bulb and outdoor entering air of _____ F dry bulb. Total design conditions shall be a minimum of _____ Btuh/Watt. The unit shall be capable of cooling operation down to 40°F (4.4°C) as shipped from the factory.

CABINET

Unit cabinet shall be constructed of phosphated, bonderized, zinc-coated, prepainted steel. Basepan shall be made of a single-piece non-corrosive, composite material.

Evaporator-fan compartment interior cabinet surfaces shall be insulated with a minimum 1/2-in. (12.7 mm) thick, flexible fiberglass insulation, coated on the air side with aluminum foil.

Cabinet panels shall be easily removable for servicing.

Outdoor coil shall be protected by metal louvered panels.

COMPRESSOR

Compressor shall be fully hermetic type with external vibration isolation.

CONDENSER SECTION

Condenser fan shall be of the direct-driven propeller type blades, riveted to corrosion-resistant spiders, and shall be dynamically balanced and discharge air vertically upwards.

Condenser coils shall have aluminum-plate fins mechanically bonded to copper tubes with all joints brazed.

Tube sheet openings shall be belled to prevent tube wear.

EVAPORATOR SECTION

Fan shall be multi-speed with direct drive motor as shown on the equipment drawings.

Fan wheel shall be made from steel, be double-inlet type with forward-curved blades with a corrosion-resistant finish and dynamically balanced.

Evaporator coils shall have aluminum-plate fins mechanically bonded to copper tubes with all joints brazed.

Tube sheet openings shall be belled to prevent tube wear.

MOTORS

Compressor motors shall be of the refrigerant cooled type with line break thermal and current overload protection.

All fan motors shall have permanently lubricated bearings, and inherent automatic reset thermal overload protection.

Condenser fan motor shall be totally enclosed.

REFRIGERANT SYSTEM

Refrigerant system shall include fixed orifice or TXV metering system.

CONTROLS

Unit shall be complete with self-contained low voltage control circuit.

APPROVALS

Unit shall be UL listed as a total package for safety requirements. All wiring shall be in accordance with NEC.

Unit shall be rated in accordance with AHRI Standards 210/240.

Cabinet insulation shall conform to ASHRAE Standard 62.2

Insulation and adhesive shall meet NFPA 90A requirements for flame spread and smoke generation.

Unit shall have a sloped drain pan that conforms to ASHRAE Standard 62.2.

ACCESSORIES

Field-installed accessories shall include solid-state compressor short-cycle device, outdoor thermostat, room thermostats, electric heaters with single-point connection, crankcase heater, and low-ambient kit.

OPTIONS AND ACCESSORIES

PART NUMBER	ITEM	DESCRIPTION	FIELD INSTALLED ACCESSORY
CPHSTART002A00	Compressor Start Kit	Compressor Start Kit assists compressor start-up by providing additional starting torque on sing phase units only.	X
CPCRKHTR008A00	Crankcase Heater	Crankcase Heater provides anti-floodback protection for low-load cooling applications.	24 – 36
CPCRKHTR004A00			42 – 60
CPLOWAMB001A00	Low Ambient Kit	Low Ambient Kit (Motormaster II Control) allows the use of mechanical cooling down to outdoor temperatures as low as 0°F (–18°C) when properly installed.	X
NRTIMEGD001A00	Time Guard II	Automatically prevents the compressor from restarting for at least 4 minutes and 45 seconds after shutdown of the compressor. Not required when a corporate programmable thermostat is applied.	X

Accessory Electric Heaters

CATALOG ORDERING NO.	NOMINAL CAPACITY (kW)	USED WITH SIZES							
		CIRCUIT BREAKER (Yes/No)	STAGES	24	30	36	42	48	60
ELECTRIC HEATERS (208/230–SINGLE PHASE–60Hz)									
CPHEATER125A0*	3.8 / 5.0	No	1	√	√	√	√	√	√
CPHEATER126A0*	3.8 / 5.0	Yes	1	√	√	√	√	√	√
CPHEATER127A0*	5.6 / 7.5	No	2	√	√	√	√	√	√
CPHEATER128A0*	5.6 / 7.5	Yes	2	√	√	√	√	√	√
CPHEATER129A0*	7.5 / 10.0	No	2	√	√	√	√	√	
CPHEATER130A0*	7.5 / 10.0	Yes	2	√	√	√	√	√	√
CPHEATER131A0*	11.3 / 15.0	Yes	2			√	√	√	√
CPHEATER132A0*	15.0 / 20.0	Yes	2					√	√

√ = Approved combination